

UNIVERSAL
LIBRARY

OU 160556

UNIVERSAL
LIBRARY

OSMANIA UNIVERSITY LIBRARY

Call No. 520
J77g

Accession No. 15229-

Author Jones, Spencer, H

Title General Astronomy

This book should be returned on or before the date last marked below.

GENERAL ASTRONOMY

BY

H. SPENCER JONES, M.A., B.Sc.

H.M. ASTRONOMER AT THE CAPE OF GOOD HOPE,
LATE FELLOW OF JESUS COLLEGE, CAMBRIDGE.

THIRD IMPRESSION

LONDON

EDWARD ARNOLD & CO.

1924

[*All rights reserved*]

*Made and Printed in Great Britain by
Butler & Tanner Ltd, Frome and London*

PREFACE

In this work the Author has endeavoured to cover as wide a field as possible and it has necessarily been somewhat difficult to decide upon what to include and what to omit, especially when dealing with the most recent developments. It is hoped, however, that the book will serve to give the reader a sufficiently complete view of the present state of Astronomy.

Mathematics has been almost entirely excluded in order that the volume may appeal to the amateur, no less than the student. Where possible mathematical methods of reasoning have been followed, which it is hoped will prove of value to students of elementary mathematical astronomy in clothing the symbols with more descriptive matter than is given in the text-books on Mathematical Astronomy.

Considerable trouble has been taken to procure a representative series of Astronomical photographs, and these have been obtained from various sources which are indicated on the plates. The Author desires to express his thanks for permission to reproduce these photographs, and great pains have been taken to ensure accurate reproductions.

The Author is greatly indebted to his friends, Mr. D. J. R. Edney and Mr. J. Jackson, both of the Royal Observatory, Greenwich; to the former for help in the preparation of many of the line diagrams, and to the latter for reading through the proofs in his absence at Christmas Island while in charge of the Expedition to observe the total Eclipse of September 21, 1922.

H. SPENCER JONES.

CHRISTMAS ISLAND.

1922.

CONTENTS

CHAP.	PAGE
I THE CELESTIAL SPHERE	1
II THE EARTH	11
III THE EARTH IN RELATION TO THE SUN	34
IV THE MOON	75
V THE SUN	108
VI ECLIPSES AND OCCULTATIONS	141
VII ASTRONOMICAL INSTRUMENTS	159
VIII ASTRONOMICAL OBSERVATIONS	191
IX THE PLANETARY MOTIONS	205
X THE PLANETS	228
XI COMETS AND METEORS	265
XII THE STARS	284
XIII DOUBLE AND VARIABLE STARS	323
XIV THE STELLAR UNIVERSE	351
INDEX	387

LIST OF PLATES

NO.	FACING PAGE
I	a. The Moon. Aged 12 days 80 b. Copernicus
II	Portion of Moon, showing Plato, Copernicus and the Apennines 100
III	Portion of Moon round Mare Nubium 106
IV	a. Sun-Spot Group. 1920 March 21. 116 b. Sun-Spot Vortices. 1908 October 7
V	Solar and Sun-Spot Spectra with Iron Arc and Furnace Comparison Spectra 122
VI	a. Sun Photographed in K_3 Light. 1910 April 11 130 b. Sun Photographed in $H\alpha$ Light. 1910 April 11
VII	Large Solar Prominence of 1919 May 29 132 a. Sobral, Brazil. 1919 May 29 d. 0 h. 2 m. G.M.T. b. Principe. 1919 May 29 d. 2 h. 13 m. G.M.T.
VIII	a. Solar Corona, 1886 August 29 134 b. Solar Corona, 1901 May 18
IX	Yerkes Observatory 40-inch Refractor 160
X	Mount Wilson Observatory 100-inch Reflector 170
XI	Dominion Astrophysical Observatory 72-inch Reflector 186
XII	a. Mars. 1899 January 30 and February 1 238 b. Jupiter. 1891 October 12 c. Saturn. 1894 July 2
XIII	a. Mars. 1909 October 5 248 b. Jupiter. 1891 October 12 c. Saturn. 1911 November 19
XIV	a. Three Minor Planet Trails 256 b. Halley's Comet and Venus, 1910
XV	a. Comet Brookes (1911 c.) 266 b. Comet Delavan (1914)
XVI	Comet Morehouse 276 a. 1908 November 10 d. 6 h. 14 m. b. 1908 November 25 d. 5 h. 55 m.
XVII	a. Parallel Wire Diffraction Grating 294 b. Star Images Obtained with Grating
XVIII	Star Clouds in Sagittarius 330
XIX	The Large Magellanic Cloud 352
XX	a. The Pleiades 356 b. The Orion Nebula
XXI	a. Great Nebula in Andromeda 362 b. Cluster M13 Hercules
XXII	a. Spiral Nebula, M101. Ursæ Maj. 370 b. Spiral Nebula, "Whirlpool," Canum Venat
XXIII	Region round the Southern Cross 376
XXIV	Nebulous Region round ρ Ophiuchi <i>Frontispiece</i>

CHAPTER I

THE CELESTIAL SPHERE

1. **The Celestial Sphere.**—Suppose an observer to be viewing the heavens on a clear night. He will see a large number of stars of different degrees of brightness, but he will have no reason to suppose that a given star is nearer to or farther from him than its neighbours. Although their distances may actually vary very considerably, they will appear to be at the same distance. The appearance will be just as though he were surrounded by a vast sphere, to the surface of which the stars are attached, the observer himself being at the centre. After some time he will notice that a change has taken place: some of the stars will have disappeared from view beneath the horizon on one side and new ones will have appeared above the horizon on the opposite side, but he will not notice any change in the relative positions of the stars which remain visible. As a result of careful observation, he might conclude that the whole sphere was turning round an axis, carrying the stars with it, and he would be able to locate very approximately the direction of the axis by noticing which stars appeared not to change their positions.

This imaginary sphere, at the centre of which the observer seems to be placed, is known as the *Celestial Sphere*. Although the sphere has no material existence, the conception is of fundamental importance in astronomy. This is due to the fact that astronomical measurements are not directly concerned with distances but with angles. Two stars are said to be at a distance of 5° apart when the directions to the two stars from the observer make an angle of 5° with one another. This angle can be measured without the observer having any knowledge of the actual linear distances of the two stars.

The apparent position of any celestial body can therefore be regarded as the point in which the line drawn to it from the observer meets the sphere. It is convenient to suppose the radius of the sphere to be extremely large compared with the distance of the Earth from the Sun, so that wherever the observer may be he can always be regarded as being fixed at the centre of the sphere. The lines from all observers to any given star will then cut the celestial sphere in the same point. All straight lines which are fixed in direction with regard to the celestial sphere may therefore be considered also as being fixed in position, and as cutting the celestial sphere in the same point.

2. It has been mentioned that the whole sphere appears to an observer to be in rotation, carrying the stars with it as though fixed to it. As will be shown in the next chapter, this rotation is only apparent, actually being due to the rotation of the Earth on its axis, the observer being carried with it. It is nevertheless convenient for the present to suppose the observer to be at rest at the centre and the sphere to be in rotation. Since only relative motion is involved this assumption is permissible.

The two ends of the axis about which the sphere rotates are called the *Poles*. They are also the points in which the axis of the Earth produced will cut the celestial sphere. If a star were situated at either of these points, its diurnal motion would be zero. The positions of the poles are not marked by any bright stars, but the bright star Polaris (the Pole-star) is at present only a little more than 1° distant from the northern pole. The southern pole is not marked by any conspicuous star.

3. The *Zenith* is the point on the celestial sphere vertically overhead. The *Nadir* is the diametrically opposite point.

The positions of the zenith and nadir depend upon the position of the observer on the Earth's surface. For an observer at the north pole of the Earth's axis, the north pole of the heavens would be in the zenith. The direction to the nadir is, in all cases, determined by the direction of gravity at the point.

The *Horizon* is the great circle of the celestial sphere which has the zenith and nadir as its two poles. The plane of the horizon is the plane passing through the observer at right angles to the direction of gravity.

Vertical Circles are great circles passing through the zenith and nadir. They are therefore perpendicular to the horizon.

The *Meridian* is the great circle passing through the zenith and the pole. It meets the horizon in the north and south points.

The *Prime Vertical* is the vertical circle at right angles to the meridian. It meets the horizon in the east and west points.

In Fig. 1 O is the observer, Z is the zenith, Z' the nadir, P the (north) pole, $NESW$ the horizon, $SZPN$ the meridian, $EZWZ'$ the prime vertical, N, S, E, W the north, south, east and west points respectively.

If A denote the position of a star, the great circle $ZAQZ'$ is the vertical circle through the star.

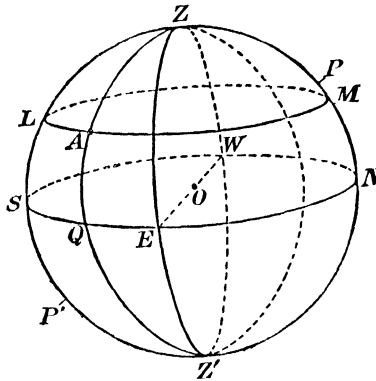

FIG. 1.—Altitude and Azimuth.

O , Observer
 N, S , North and South Points
 $NESW$, Observer's Horizon
 P, P' , The Poles

Z , The Zenith
 Z' The Nadir
 $NPZS$, The Meridian
 $EZWZ'$, Prime Vertical

A , Star
 $ZAQZ'$, Star's Vertical
 LAM , Star's Almucantur

SQ or $SWNQ$, Star's Azimuth
 QA , Star's Altitude
 ZA , Star's Zenith Distance

The position of the star can be fixed if its distance from the zenith be known and also the angle between the vertical circle through the star and the meridian, i.e. if the arcs ZA and SQ be known.

The Zenith Distance of a body is its angular distance from the zenith (ZA).

The Altitude of a body is its angular elevation above the horizon (QA).

Obviously the altitude and zenith distance are complementary angles.

The Azimuth of a body is the angle at the zenith between the meridian and the vertical circle through the star. It is therefore measured by the arc intercepted on the horizon between these two circles.

Azimuth is usually reckoned from the south point westwards. Thus in Fig. 1 the azimuth of the body A is, according to this convention, $360^\circ - SQ$. It is sometimes measured, however, either east or west of south up to 180° . Then the azimuth of A would be E. of S. by an amount SQ . The former method is the more convenient, though it is really immaterial what convention is adopted provided that it is stated and adhered to. In this book, azimuths will be reckoned from 0° to 360° starting from the south point westwards.

An *Almucantur* is a small circle of constant altitude or zenith distance (i.e., parallel to the horizon). LAM is the almucantur through the star A .

4. *The Celestial Equator* is the great circle which has the two poles of the heavens as its poles. It is the circle in which the plane of the Earth's equator meets the celestial sphere.

Hour-Circles are great circles passing through the two poles. They are therefore perpendicular to the equator.

The meridian is obviously the hour-circle through the zenith and is therefore perpendicular to the equator as well as to the horizon.

In Fig. 2, O is the observer at the centre of the celestial sphere, Z is the zenith, P, P' the poles, $NESW$ the horizon, $ELWM$ the equator; A denotes the position of a star and $PAQP'$ the hour-circle through A .

The Declination of a body is its angular distance from the equator. It is reckoned as positive for bodies north of the equator and negative for those south.

In Fig. 2, QA is the declination of A .

The North Polar Distance of a star is its angular distance from

the Earth rotates on its axis a complete rotation will always take place in a period given by the quotient of 24 hours by the sine of the latitude. This agrees exactly with Foucault's result : the latitude of Paris is $48^{\circ} 50'$, the sine of this latitude being about .75. This value divided into 24 hours gives the value of 32 hours, actually observed. The experiment of Foucault has frequently been repeated, and provided that proper precautions are taken, a result in agreement with the preceding rule is always obtained. The rotation of the Earth is thereby experimentally verified.

10. Theory of Foucault's Experiment.—Foucault's experiment is of such fundamental importance and the theory is so simple that it may be given here. We will suppose for simplicity that the pendulum is set swinging in the meridian at a (Fig. 4). No loss of generality is thereby produced, as the rate of rotation does not depend upon the direction of swing, a constant angle between two given directions being involved. The direction of swing is therefore along the tangent, ac , to the Earth at the point a , which meets the axis OP produced in c .

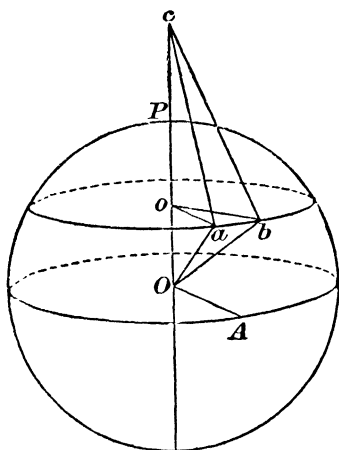

FIG. 4.—Theory of Foucault's Experiment.

A short time later suppose that the Earth has rotated through a small angle from west to east and carried the pendulum to the point b on the same parallel of latitude. The tangent to the Earth in the meridian at b obviously meets OP in the same point c . The pendulum is still swinging in the direction ac , so that relatively to the tray it will have apparently changed its direction in the clockwise direction through an angle bca . In the same time the Earth has rotated through the angle boa , where o is the centre of the parallel of latitude on which a and b are situated. o is also on OP . The rates of rotation being inversely proportional to the angles turned through in the

same time, it follows that the rate of rotation of the pendulum is to that of the Earth as angle bca to angle boa . But

$$\frac{\text{angle } bca}{\text{angle } boa} = \frac{\text{arc } ab}{ac} \div \frac{\text{arc } ab}{ao} = \frac{ao}{ac} \\ = \sin acO = \sin aOA = \text{sine latitude.}$$

11. Other Proofs of the Earth's Rotation.—There are several other methods of establishing the Earth's rotation of which two only need be referred to. The first of these methods was originally suggested by Newton in 1679. Suppose a heavy object to be dropped vertically from a great height, say from the top of a high tower. Then, if the Earth is in rotation, since the top of the tower must be moving more rapidly than the bottom, an object dropped from the top should retain its original easterly velocity whilst falling, and should strike the Earth a little to the east of the point vertically beneath the point of projection. The deviation is relatively small, so that slight disturbing causes, such as the effects of air-currents, become very important and render the experiment much less conclusive than that of Foucault. Some experiments on this principle were made in 1831 in a disused mine-shaft in Saxony : a free fall of over 500 feet was available, but the theoretical deviation for this distance is only slightly greater than 1 inch. The results of individual experiments differed considerably *inter se*, but the mean of a large number was in fairly good agreement with the theoretical value.

The second of these methods was also suggested by Foucault and performed by him. It depends upon the properties possessed by the gyroscope of maintaining the direction of its axis invariable in space, unless it is acted upon by any disturbing forces. The gyroscope consists essentially of a rapidly spinning wheel very carefully balanced, which is mounted in gimbals with as little friction as possible, so that it is free to swing in any direction. If the gyroscope is set in rotation, its axis will continue to point in the same direction in space, so that the rotation of the Earth will appear to make it rotate, the theory being the same as for the pendulum experiment. By using a gyroscope, the rotation of the Earth may readily be made evident to a large audience.

12. Possible Variability of the Earth's Rotation.—The period of rotation of the Earth on its axis provides the fundamental means of measuring time. It is therefore important to know whether this period of rotation is constant, in other words whether the day changes its length. It would seem from mechanical considerations that the length cannot remain absolutely invariable: any cause which would tend to change the angular momentum of the Earth must change its period of revolution. Such possible causes are the friction of the tides, transportation of matter from one part of the Earth's surface to another by rivers, etc., elevation and subsidence of the ocean bottom. It might be thought that clocks would provide a means of checking the constancy of the period of rotation, but this is not possible, as the period is much more constant than the rates of even the best clocks, so that the constancy of the period is used to check our clocks.

It is only by comparing the times at which such phenomena as eclipses or occultations occur with the calculated times, or by comparing the motions of the Moon and planets with their theoretical motions, that changes can be detected. It is found in this way that the period of rotation remains remarkably constant: there is some evidence that the length of the day is at present increasing, at a rate of the order of one-hundredth of a second per century, but it is not probable that this rate of increase has remained constant in the past or that it will remain so in the future.

13. The Size of the Earth.—The problem of determining the size of the Earth reduces to the problem of determining the number of miles in one degree of the Earth's surface. A double operation is involved in this. Two fundamental points lying as nearly as possible on the same meridian are chosen on the Earth's surface and the actual distance between these is measured by a surveying operation which is called a geodetic triangulation. The latitudes of the two stations are then determined by astronomical observations with as much accuracy as possible. The geodetic portion of the observation involves the most time and work. The survey work is based upon an initial base-line which must be very carefully measured. Starting from this base-line a chain of triangles is laid down

connecting the two points. The corners of the triangles are marked by suitable objects for observation, which may be either such well-defined marks as church spires or specially erected artificial observation posts. With accurate surveying theodolites the angles of these triangles are measured in succession, so that, starting from the measured base-line, the lengths of the sides can be calculated by trigonometry. It is then possible to deduce the distance apart of the two stations in latitude which can be compared with the difference of latitude deduced from the astronomical observations. The length of one degree of the Earth's surface is thus derived and thence its circumference and radius. In this way many long arcs of meridians have been measured.

Such observations also give information as to the exact form of the Earth. The problem is a highly technical one, and it would be far outside the limits of this book to enter into details. It seems probable that no simple geometrical solid will accurately represent the shape of the Earth, even when local variations, such as hills and valleys, are disregarded. It has, however, been found that the Earth can be represented with sufficient accuracy for most purposes as an oblate spheroid, i.e. a figure formed by the revolution of an ellipse about its shorter axis. The Earth is flattened at the poles, the diameter along the axis being shorter than a diameter in the equatorial plane. The most accurate determination is probably that of Helmert, which gives for the longer semi-axis 20,925,871 feet and for the shorter semi-axis 20,855,720 feet, or approximately 3,963 miles and 3,950 miles respectively. It follows that the nearer the poles the greater is the length of one degree in latitude. Thus in the latitude of Sweden, it is necessary to travel more than half a mile farther than near the equator in order to increase the latitude by one degree.

It is customary to define the flattening of the Earth or of any other oblate body by a quantity called the *ellipticity*. This is defined as the ratio of the difference between the major and minor axes to the major axis. It is expressed as a fraction and gives a measure of the departure of the Earth from a sphere. The ellipticity corresponding to Helmert's values for the axes is

$$\frac{1}{298.3}$$

The ellipticity can be determined also by other methods, as e.g. by pendulum observations which really determine the variation of gravity over the Earth's surface and also by certain astronomical methods.

The triangulation method is, however, the most accurate and it is, in addition, the only one which determines also the size of the Earth.

14. The Mass of the Earth.—The problem of determining the mass of the Earth is often incorrectly spoken of as “weighing the earth.” By the mass of a body is meant the quantity of matter contained in it. The weight of a body at the surface of the Earth is the force of attraction which the gravitation of the Earth exerts on the matter forming the body; this varies for the same quantity of matter according to its position on the Earth's surface, whilst on the Sun, for instance, the weight of a given body would be about twenty-eight times its weight on the Earth. The phrase “the weight of the Earth” therefore has no meaning. It is quite possible, however, to determine the quantity of matter in the Earth, or the *mass* of it. Another aspect of the same problem is to determine the mean density of the Earth since, its size and volume being known, its mass can then be calculated.

The basis of all the methods is the *Law of Gravitation*, first discovered by Newton. This states that any two particles of matter attract one another with a force which is directly proportional to the product of their masses and inversely proportional to the square of the distance between them. Expressed algebraically, the law may be written in the form

$$f = \gamma \frac{m_1 m_2}{r^2},$$

in which m_1, m_2 are the masses of the two particles, r their distance apart, f is the force of attraction and γ is a numerical and universal constant, called the *Constant of gravitation*. The constancy of γ implies that the force of attraction between the two particles does not depend upon their physical or chemical constitutions or upon their positions in the universe. Its value is, of course, dependent upon the units in which the masses and distance are expressed.

The law of gravitation as stated above is valid only for

"particles," i.e. for masses of very small size. To find the attraction between two masses of finite size, it is necessary to sum up the attractive forces between every pair of particles composing them. The result in general will be a complicated expression, depending upon the sizes and shapes of the two bodies. In the special case of a spherical body the result is very simple, provided that the sphere is of the same density throughout (homogeneous) or is built up of successive concentric spherical layers. The force of attraction between such a sphere and any particle is then the same as that between a particle supposed placed at the centre of the sphere and of the same mass as the sphere and the second particle. This result will hold approximately for the Earth.

15. Determination of the Mass of the Earth.—The principle of all the methods for determining the mass of the

Earth is to compare the force of attraction between two known masses with the force of attraction between one of the two masses and the Earth. The difficulty of the determination is due to the smallness of the constant of gravitation.

If the masses are expressed in grams and their distance apart in centimetres, then the value of γ is 6.658×10^{-8} dynes. Thus two spheres of lead weighing each 10 kilograms and with their centres 12 cms. apart would attract one another with a force of only $\frac{1}{2} \frac{1}{2}$ nd of a dyne. Many different methods have been used, of which it will be sufficient to refer to three, involving somewhat different principles.

(i) *The Mountain Method.*—This was one of the earliest methods to be used. The principle can be seen from Fig. 5. Two convenient stations, *A* and *B*, are selected on opposite sides of a mountain. Suppose that, in the absence of the mountain, a star *S* would pass at culmination near the zenith

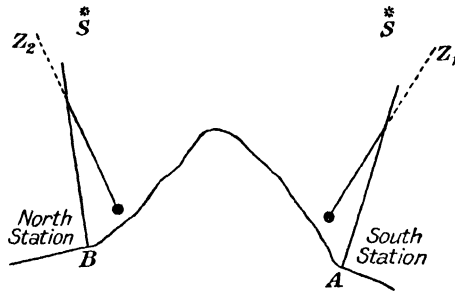

FIG. 5.—The Mountain Method of Determining the Mean Density of the Earth.

at the two stations. The mountain mass will attract a plumb-bob suspended at A , and since the direction of the plumb-line (or the direction of the force of attraction due to gravity) intersects the celestial sphere in the zenith, astronomical observations will shew the zenith at A to be displaced by the mountain mass to Z_1 , since the star S at culmination will apparently be displaced away from the zenith and towards B . Similarly, the zenith at B will be displaced in the opposite direction. The distance apart of the stations A and B can be determined by a survey operation and the difference of their geographical latitudes calculated, since the dimensions of the Earth are known. The difference of latitude determined from astronomical observations at the two stations A and B , being the angle between the two plumb-lines, will be greater than the calculated value. The difference between the observed and calculated latitude difference is due to the attraction of the mountain. The size of the mountain can be determined by surveying and its density estimated from an examination of the rocks composing it. The mass of the mountain can thus be approximately obtained, and from the observed deflection of the plumb-line the relative masses of the Earth and mountain can be computed. Thus the mass of the Earth is obtained.

Observations by this method were made in 1740 by Bouguer at Chimboraso in South America, and in 1774 by Maskelyne at Schiehallien in Scotland. The method is not equal in accuracy to the two following methods, since the mean density of the mountain mass cannot be determined with sufficient accuracy, there being no certainty that the surface rocks have the same density as the interior of the mountain.

(ii) *The Torsion-Balance Method.*—The principle of this method is illustrated in Fig. 6. x, x are two small balls carried at the ends of a light rod which is suspended horizontally from its mid-point by a fine wire. Two large masses W , suspended at the same level from the ends of another horizontal rod, are brought into the position W_1 near to the small masses x . The attraction between the large and small masses pulls the rod carrying the latter out of position, until the attracting force is balanced by the force due to the stiffness of the suspending wire and arising from the twist in it (position

x_1x_1). The masses W are then brought into the position W_2 , near the masses x but on the opposite side, deflecting them into the position x_2 . The total angle through which the rod moves from the position 1 to the position 2 is accurately observed with a telescope, and this angle is four times as great

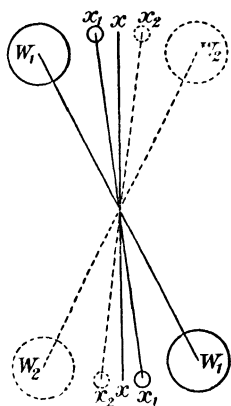

FIG. 6.—Principle of the Torsion Balance Method of Determining the Mass of the Earth.

as the angle through which the rod would be deflected by bringing one sphere up to one ball. The torsional force in the wire, tending to twist the rod back into its original position, is proportional to the angle through which the rod is turned. The constant of the proportion can be easily determined. For this purpose, the masses W are removed and the rod is twisted through a small angle; it will then swing to and fro, and if the time of swing be observed it is possible to determine the constant. This enables the attracting force between the masses W and x to be calculated and therefore the constant of gravitation to be determined.

When the coefficient of gravitation is known, the mass of the Earth (or its equivalent, the mean density) is readily determined. The weight of any mass due to the Earth's attraction is known and the mass of the Earth is therefore obtained from the formula $f = \gamma m_1 m_2 / r^2$, f and m_1 being known (weight and mass), r being the radius of the Earth and γ the gravitation constant.

This experiment was first performed by Henry Cavendish in 1797-8. The apparatus used is shown in Fig. 7, hh is the torsion rod hung by the wire lg ; x, x are the attracted balls 2 inches in diameter, hung from its ends; W, W , the attracting masses, which are of lead, 12 in. in diameter. The torsion balance is enclosed in a case so as to exclude draughts of air and the masses W are suspended outside. The masses are turned by a string acting on the pulley P . T, T are the telescopes for observing the deflection of the masses x , mirrors n, n at the ends of the rod hh reflecting light from the lamps at the side of the case. The case

surrounding the apparatus serves to prevent disturbances arising from air currents.

An improved form of this experiment was performed by Boys in 1895, the apparatus being made more delicate and reduced in size. The attracting masses, W , which were leaden spheres, 10 cms. in diameter and weighing 7.4 kgms. each, were suspended from the top of the case at different levels in order not to neutralize each other's effect and the attracted

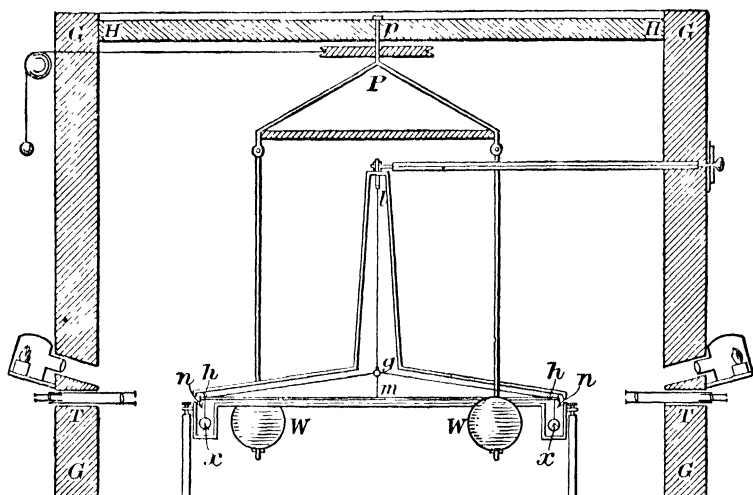

FIG. 7.—Cavendish's Apparatus.

hh , torsion rod hung by wire lg ; x, x , attracted balls hung from its ends; W, W attracting masses.

masses were placed at the corresponding levels. The attracted masses x, x were of gold, 5 mm. in diameter, weighing about 1.3 gms., and were suspended by quartz fibres from the ends of a small rectangular mirror Q , about 2.4 cms. in length, which formed the torsion rod. The mirror was suspended by a very fine-drawn quartz thread, possessing great strength. It reflected a distant scale, enabling the deflection to be read with great accuracy. The attracting masses were moved from one position to the other by rotating the top of the case. A diagram of the apparatus is shown in Fig. 8 on a scale of about $\frac{1}{7}$.

The value obtained by Boys is probably the most accurate

yet determined. He found for the constant of gravitation the value 6.658×10^{-8} dynes, corresponding to a mean density for the Earth of 5.527. The value found by Cavendish was 5.448.

(iii) *The Common Balance Method.*—Suppose a spherical

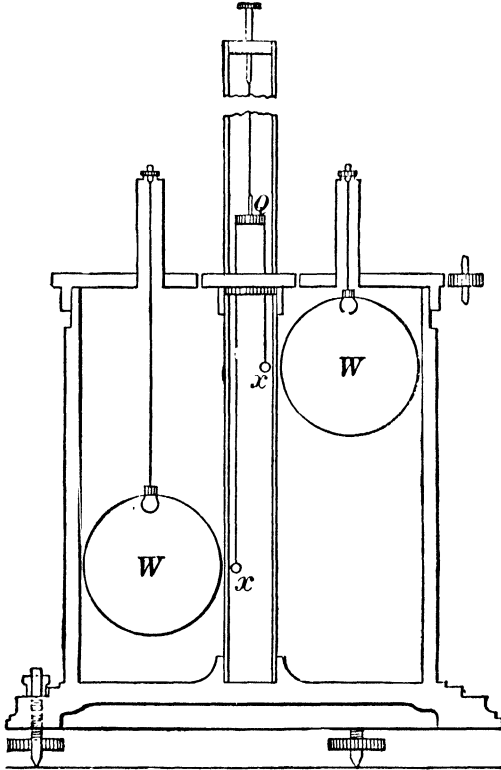

FIG. 8.—Boys' Torsion Balance.

mass to be hung from one arm of a balance and counterpoised by another mass at the end of the other arm. If a heavy mass is introduced beneath the suspended mass, it will exert a slight additional pull upon it, causing an apparent increase in weight which can be determined by adding a small weight to the other pan. The weight added determines the attraction between the suspended mass and the attracting mass,

and knowing this, the constant of gravitation can be determined as before.

The apparatus used by Poynting in 1891 in applying this method is shown in Fig. 9. Lead spheres *A* and *B*, weighing 20 kgm., were hung from the two arms of the balance, which

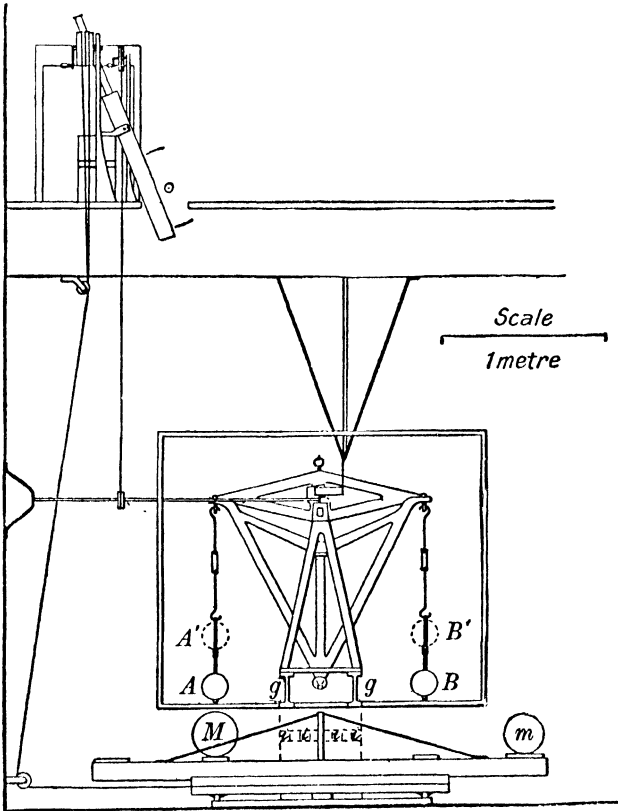

FIG. 9.—Poynting's Gravity Balance.

had a 4-ft. beam. The balance was supported in a case, to exclude draughts, above a turn-table whose axis was below the central knife-edge of the balance. On this turn-table was the attracting mass *M* of 150 kgm., which could be brought under each of the suspended masses in turn. It was balanced by a smaller mass *m*, which was introduced to prevent a tilting of the floor by the heavy mass *M*. The attraction of

m was, of course, allowed for. After rotation, a balance was again obtained by sliding along a small rider. This was done from outside the case and the position of the rider was observed with a telescope. Poynting's value for the mean density was 5.493.

The mean density of the Earth found from these experiments corresponds to a total mass of about 6×10^{27} grams, or about 5×10^{21} tons.

16. The Interior of the Earth.—A knowledge of the constitution of the interior of the Earth must be derived by indirect methods, since it is not possible to penetrate the surface sufficiently far to obtain any information of value. The deepest mine-shaft in the world, at the Morro Velho Mine in Brazil, reaches only to a depth of 6,426 ft., a distance which is infinitesimal compared with the radius of the Earth. The temperature of the Earth increases rapidly from the crust inwards, the average rate of increase in descending a mine being about 1° F. per 200 ft. Volcanoes and hot springs also provide evidence that the interior is hot, but we have no direct evidence as to the temperature gradient at great depths.

The mean density of the Earth is about twice that of the surface rocks, the high value being doubtless due to the great pressure to which the interior is subjected. It was formerly believed that the high temperature in the interior necessitated a liquid core, and the outflow of molten lava from volcanoes during their periods of activity seemed to afford corroborative evidence of this view. It is not now, however, believed to be correct, as serious objections are involved on theoretical considerations.

The tides in the ocean are due mainly to the gravitational attraction of the Moon on the water, as will be seen in Chapter IV. If the interior of the Earth were fluid with a solid exterior shell, the gravitational pull of the Moon on the fluid interior would deform the surface shell, with the result that it would rise and fall with the ocean waters. The height of the tides would therefore be very materially reduced, and the observed tides could not be accounted for. If the interior of the Earth is not fluid and yet not perfectly rigid, an elastic deformation will be produced by the attraction of the Moon,

but this will not greatly decrease the height of the tides. A comparison between the observed and theoretical heights of the tides, in fact, enables an estimate to be made of the rigidity of the Earth, and it was from such considerations as these that Lord Kelvin was led to conclude that the Earth as a whole must be more rigid than glass but not quite so rigid as steel. It therefore appears probable that the interior is solid, with a high rigidity.

The form of the Earth provides another argument leading to a similar conclusion. It has been seen that the Earth is not quite spherical but has the form of a spheroid, being flattened at the poles. Now it can be shown mathematically that a fluid mass of matter in rotation, as the Earth is, must assume a spheroidal form, and it is not unreasonable to suppose that the ellipticity of the Earth's figure is due to its rotation. The actual value of the ellipticity is, however, not that of the figure which would be assumed by a fluid mass of the size and density of the Earth, rotating in a period of one day. In order to account for the observed value, it is again necessary to suppose that the interior of the Earth is a solid, possessing high rigidity.

Corroborative evidence is provided by the speed with which earthquake waves travel. The interior of the Earth being hotter than the surface heat is gradually passing outwards, and the interior contracts as it cools. The outer crust is supported by the inner nucleus and it is probable that earthquakes are due to the outer crust adapting itself to the contracting nucleus. When an earthquake occurs, the disturbance spreads outwards through the surrounding earth in a manner analogous to that in which the discharge of a cannon produces a disturbance spreading out in the air, which the observer detects as a sound. The earthquake waves cause minute oscillations of the surface extending to great distances, and these oscillations can be detected with the aid of a delicate instrument, called a seismograph, which greatly magnifies them. At a great distance from an earthquake two separate disturbances are recorded, and it has been shown that one of these is due to waves which travel through the interior of the Earth and that the second is due to waves which travel over the surface. From the velocity of the waves which

travel through the interior, the rigidity of the Earth can be calculated. The results so found are again not compatible with the existence of a fluid nucleus.

17. The Variation of Latitude.—Connected with these theories is the phenomenon of the variation of latitude. It was shown mathematically by Euler that if a body which, like the Earth, is symmetrical about an axis is set in rotation about that axis and is not acted upon by any external forces, it will continue to rotate about that axis with a constant angular velocity. But if it is set in rotation about any other axis, the axis round which the body will turn—in the case of a nearly spherical body such as the Earth—will always point in the same direction in space (i.e. among the stars), but it will describe a cone in the Earth, the axis of this cone being the axis of figure of the Earth. Euler showed that this cone would be described in a period of 305 days. This is equivalent to saying that the Earth's axis, instead of being directed to the same point in the sky, will describe a small circle amongst the stars. Since the elevation of the pole at any station is equal to the latitude of the station, the effect would be detected by a regular change of latitude of places on the Earth, with a period of 305 days.

The existence of such a variation was first detected by Küstner in 1888, who found a variation in the latitude of Berlin. This result was confirmed by Chandler who, from a more thorough discussion of several series of observations, showed that the period of the variation was about 430 days, instead of the predicted 305 days. This result has been fully confirmed by later investigations which have shown that the movement of the Earth's axis of rotation about its mean position is compounded of two motions, one of semi-amplitude about $0''\cdot18$ with a period of 432 days, and the other of semi-amplitude about $0''\cdot09$ with a period of exactly one year. The latter is mainly due to meteorological causes, involving movements of masses of air from one portion of the Earth to another. The former is the motion investigated by Euler who, however, in deducing the period, had assumed the Earth to be perfectly rigid. Other considerations have just led us to the conclusion that this is not the case, and by making the appro-

priate modification in Euler's investigation, the observed period can be accounted for.

The motion of the Earth's pole (i.e. the end of its axis of rotation) about its mean position from 1912 to 1920 is illustrated in Fig. 10. In this figure, the origin of the co-ordinates corresponds to the mean position of the pole. A displacement along the positive direction of the x axis, indicates a movement

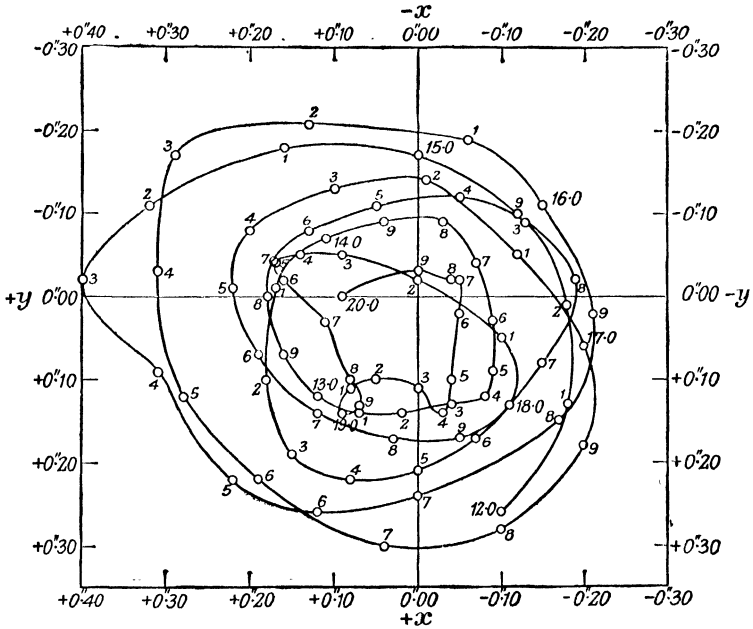

FIG. 10.—The Movement of the Earth's Pole, 1912.0–1920.0.
($0''.01 = 1$ foot on Earth's surface.)

along the meridian of Greenwich ; a displacement along the y axis indicates a movement in the perpendicular direction. During the period, the pole has described the irregular curve shown, the position at intervals of $\frac{1}{10}$ th year being indicated. When the two components of the motion are in the same phase, the total motion is large, as in 1916 ; when in opposite phase, the total motion is small, as in 1919. An angular motion of $0''.01$ corresponds approximately to a movement of 1 ft. on the Earth's surface.

18. **The Earth's Atmosphere.**—The Earth is surrounded by an atmosphere which is a mixture chiefly of nitrogen and oxygen. At the surface of the Earth, dry air consists principally of about 78 per cent. of nitrogen, 21 per cent. of oxygen, nearly 1 per cent. of argon, and smaller amounts of carbon dioxide, hydrogen, neon, helium and other rare gases. Water-vapour is present at the surface to the extent of about 1.2 per cent. of the total.

At great heights, the lighter gases predominate, the percentage of hydrogen and helium beyond 80 kilometres probably being very large: at the same time, the density rapidly decreases upwards, so that the total amount of hydrogen is not large.

If the atmosphere were homogeneous, having the same density throughout as at the surface, it would only extend to a height of about 5 miles, but on account of the rapid decrease in density upwards the actual height is very much greater than this. A lower limit to the height can be obtained from observations of meteors (*see* Chapter XI) which, on coming into the Earth's atmosphere from outside with a large velocity, are raised to incandescence by friction. If observations of the path of the same meteor are made from two stations at some distance apart, it is possible to calculate the height of the meteor. The maximum heights so obtained are about 120 miles. The actual height to which the atmosphere extends must be very much greater than this, as the meteor will penetrate some considerable distance through the outer very rarefied layers before its temperature is raised sufficiently to render it visible.

The blue colour of the sky is a result of the Earth possessing an atmosphere. When light passes through a medium containing numerous small particles, a certain proportion of the light is scattered sideways by these particles and the shorter the wave-length of the light the greater will be the scattering. The blue light is therefore scattered to a much greater extent than the red light. The light as it travels onward is thus gradually robbed of its blue portion and will appear red. This effect is readily seen by looking at a street lamp from a short distance in a fog. The light from the Sun which passes through the upper layers of the Earth's atmosphere

would, in the absence of the atmosphere, pass outside the Earth and the sky would therefore appear black and the stars would be seen at all hours of the day. The molecules in the atmosphere, however, scatter the blue light towards us, so producing the blue appearance of the sky. The more free the air is from the comparatively large dust particles, the purer and deeper will be the blue. To the same cause are due the golden tints of sunset. When the Sun is near the horizon, the light from it which reaches an observer passes through a much greater length of atmosphere than when it is higher in the heavens. A greater proportion of blue light being then lost, the light reaching the observer is tinted red. The beautiful colours which frequently accompany the setting of the Sun are mainly due to dust particles and depend very largely upon the amount of dust in the atmosphere.

Another phenomenon which is due to the Earth having an atmosphere is twilight. Were there no atmosphere, darkness would result the moment the Sun had set ; but the particles in the upper atmosphere continue to reflect light from the Sun for some time after it has actually disappeared below the horizon. The amount of light reflected becomes inappreciable after the Sun has sunk about 18° below the horizon, and the time taken for this to occur is generally used as a measure of the duration of twilight. For places near the equator, the Sun will move approximately in a great circle which meets the horizon at right angles and it will descend 18° below the horizon much more rapidly than at a place in a higher latitude, for which the Sun moves in a great circle cutting the horizon obliquely. The duration of twilight is therefore considerably greater in higher latitudes than it is near the equator.

19. Refraction.—Another atmospheric effect, for which it is necessary to make allowance in astronomical observations, is known as Refraction. When a ray of light passes from one medium into another of different density its direction is changed. If it passes from a less dense into a denser medium it is bent towards the normal to the interface between the two media ; conversely, if it is passing into a rarer medium it is bent away from the normal.

If we suppose, for simplicity, that the Earth is flat and

the atmosphere homogeneous with a definite upper surface, a ray of light coming from a star, or other body, will, on entering the denser atmosphere, be bent towards the normal, i.e. towards the direction to the zenith. The body will appear to an observer to be in the direction from which the ray comes; the effect of refraction is, therefore, to make the apparent zenith distance of a body less than it actually is. Thus, in

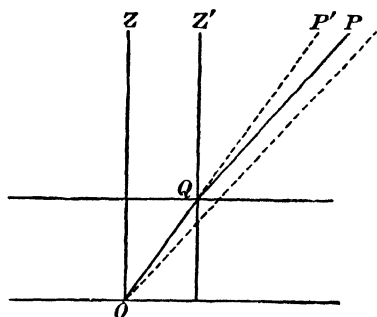

FIG. 11.—Elementary Theory of Refraction.

Fig. 11, PQ is a ray which enters the atmosphere at Q and is refracted towards an observer at O . The angle ZOP' or $Z'QP'$ is a measure of the apparent zenith distance; the angle $Z'QP$ is a measure of the true zenith distance. Refraction, therefore, appears to increase the altitude of the body by the angle PQP' . The effect of refraction increases with zenith

distance, reaching its maximum on the horizon when the body is rising or setting. For large zenith distances, the rate of increase of the refraction with zenith distance is large, so that in the case of the Sun or Moon near the horizon, the refraction is appreciably different for the upper and lower limbs. The lower limb is raised by refraction more than the upper, so that the apparent vertical diameter becomes less than the horizontal. This gives rise to the well-known flattened shape of the Sun or Moon at rising and setting.

An approximate formula for the change in zenith distance due to refraction, which is valid for all except large zenith distances, can be obtained from elementary considerations. The curvature of the Earth is neglected and the assumption made that the atmosphere is horizontally stratified, so that the density is the same for all points at the same height. It then follows from the laws of optics that a ray of light will pass through the atmosphere in such a manner that $\mu \sin Z$ is a constant at every point of its path, μ being the refractive index of the air at any point and Z being the angle which the ray at that point makes with the vertical. If Z_0

is the value of Z when the ray enters the atmosphere, then, since *in vacuo* the refractive index is unity,

$$\mu \sin Z = \sin Z_0.$$

In this formula μ and Z can now be taken as referring to the surface of the Earth, and if ζ is the change in the zenith distance due to refraction, $Z_0 = Z + \zeta$. Hence

$$\begin{aligned} \mu \sin Z &= \sin(Z + \zeta) \\ &= \sin Z + \zeta \cos Z, \text{ since } \zeta \text{ is small,} \\ \text{or } \zeta &= (\mu - 1) \tan Z. \end{aligned}$$

Hence, except for large zenith distances, when the curvature of the Earth cannot be neglected, the refraction is proportional to the tangent of the zenith distance.

The index of refraction of a gas depends upon its temperature and pressure, and therefore the coefficient of $\tan Z$ in the preceding formula will depend upon the temperature and the barometric height. The refraction decreases with increase in temperature and increases with increase in barometric height. Tables, such as those of Bessel, have been constructed giving the refraction with accuracy for any zenith distance: these are based upon a standard temperature and pressure. Auxiliary tables are given containing the corrections to apply for other temperatures and pressures.

For air at zero Centigrade and a barometric height of 76 cm. μ is 1.000294. The approximate refraction formula then gives, expressing ζ in seconds of arc,

$$\zeta'' = .000294 \times 206265 \times \tan Z = 60''.6 \tan Z,$$

which is sufficiently accurate down to about 70° Z. D. For small zenith distances, the refraction is approximately one second of arc per degree of Z. D.

At an apparent altitude of 0° the mean refraction is about $35'$, and at altitude $0^\circ 30'$ it is about $29'$. The angular diameter of the Sun or Moon being about $30'$ it follows that when on the horizon the effect of refraction is to shorten the vertical diameter to about $24'$, whilst the horizontal diameter remains unaltered. The resultant flattening is therefore very pronounced.

Corrections for refraction must be applied to all astronomical observations in order to reduce *apparent* zenith distance to *true* zenith distance.

20. Dip of the Horizon.—Another correction which it is necessary to apply to certain astronomical observations is that for the “dip of the horizon.” In taking observations at sea, the true altitude of a body is not observed, but the angular distance between the body and the visible horizon or sea-line. Owing to the curvature of the Earth, this visible horizon does not coincide with the true horizon, but falls below it by an amount depending upon the height of the observer above sea-level. The angular difference between the true and visible horizons is called the *Dip of the Horizon*.

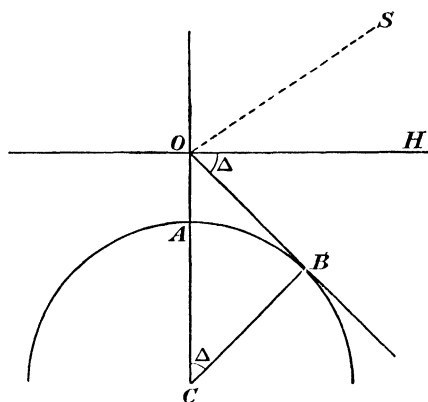

FIG. 12.—The Dip of the Horizon.

If, in Fig. 12, O is an observer and C the centre of the Earth (supposed spherical), then OH which is perpendicular to OC is the trace of the astronomical horizon. If OB is a tangent to the Earth at the point B , then B is the point on the sea-line in the direction OB . The observed altitude SOB , of a star S , is greater than the true altitude, SOH , by the angle HOB , which is denoted by Δ , and gives the *dip of the horizon* for the observer at O . Since CB , BO are perpendicular and also CO , OH , the angle $ACB = \text{angle } BOH = \Delta$. Hence, if R is the Earth's radius and h the height of the observer above sea-level,

$$\cos \Delta = \frac{R}{R + h}.$$

Since Δ is small and is expressed in circular measure, and since h is small compared with R , this formula gives

$$1 - \frac{\Delta^2}{2} = 1 - \frac{h}{R}$$

$$\text{or } \Delta = \sqrt{\frac{2h}{R}}.$$

Expressing Δ in minutes of arc (3,438 minutes in one radian)

and h in feet, and putting $R = 20,880,000$ ft., the formula gives

$$\Delta = \frac{3438}{3231} \sqrt{h}.$$

An approximate formula for the dip is thus:—

$$\Delta \text{ (in minutes of arc) } = \sqrt{h} \text{ (in feet).}$$

This formula is sufficiently accurate for observations at sea, which are not of extreme precision. The dip is subtracted from *observed* altitude to obtain *apparent* altitude, and this when corrected for refraction, gives *true* altitude.

CHAPTER III

THE EARTH IN RELATION TO THE SUN

21. **The Apparent Motion of the Sun.**—Although the Sun rises and sets and exhibits other phenomena due to the diurnal motion of the Earth on its axis, it is at once apparent that its motion on the celestial sphere is much more complicated than the motions of the fixed stars. In § 7 it was shown that any given star always culminates at the same zenith distance. But if the motion of the Sun, as seen by an observer in the northern hemisphere, be considered, it is evident that in the summer it reaches a much higher altitude at culmination than in the winter. If the Sun be regularly observed, starting in the spring about the end of March, i.e. at the vernal equinox, it will be seen that then it rises approximately in the east point of the horizon and sets in the west point. Each succeeding day it will be found (the observer being assumed in the northern hemisphere) to rise and set a little farther towards the north and to reach a slightly higher altitude at culmination, though on any one day its path on the celestial sphere is very nearly a small circle. Towards the end of June, the altitude reached at culmination attains its maximum and the Sun then rises and sets at its farthest north. Thereafter, it retraces its course and near the end of September, at the autumnal equinox, it again rises and sets in the east and west points respectively. It continues to move southwards until, near the end of December, it reaches a minimum altitude at culmination and rises and sets farthest south. Thereafter the Sun commences to move gradually northwards again and completes one cycle by the next vernal equinox, in the period of 365 days. These movements should be considered in conjunction with Fig. 2.

The strong light of the Sun hinders the stars being seen at the same time. But we know that the diurnal motion of the

stars is only apparent and due to the rotation of the Earth on its axis and that therefore, at any given place, any one star will always rise and set at the same points of the horizon. It follows that the Sun moves northwards amongst the stars from the winter to the summer solstice and southwards from the summer to the winter solstice. Moreover, the stars which rise in the eastward horizon as the Sun is setting in the westward are not the same in summer and winter. Suppose, for instance, that the three bright stars in the belt of Orion are observed rising in the east in the winter ; it will be found that they rise each evening 4 minutes earlier than the preceding evening. If one evening they are observed to be rising just as the Sun is setting, then a few weeks later it will be found that they are well up in the eastern sky at sunset. It follows, therefore, that the Sun moves eastwards amongst the stars as well as north and south. This eastward motion continues throughout the year, during which period it completes an entire circuit of the heavens and at the end of it has returned to its original place.

If accurate determinations of the Sun's position relative to the stars are made with a meridian circle and the positions are plotted on a celestial globe, it will be found that the plotted points lie on a great circle which cuts the equator at an angle of about $23\frac{1}{2}^{\circ}$. This great circle is known as the *Ecliptic*, being originally so called because it was found that eclipses only occurred near the times when the Moon crossed this great circle. The ecliptic may be regarded as the path of the Sun on the celestial sphere and it is from this point of view that we have approached it. But it must be remembered that it is not possible to say, *a priori*, whether the relative motion of the Sun and Earth is due to the motion of the Sun or to that of the Earth. The Earth, if seen from the Sun, would appear to move in this same path, though remaining six months behind, since lines drawn from the Earth to the Sun and from the Sun to the Earth respectively point to diametrically opposite points on the celestial sphere. It is known, however, from other considerations referred to later, *see* §§ 116, 119, that in reality it is the Earth which is in motion around the Sun. If, then, mention is made of the motion of the Sun in the heavens, what is really meant is the apparent motion due to the motion of the Earth.

22. *The Ecliptic* may therefore be defined as the trace on the celestial sphere of the plane of the orbit of the Earth round the Sun.

The Zodiac is a zone extending along the ecliptic. It is divided into twelve signs each comprising 30° of longitude and known by the name of the constellation included.

The Obliquity of the Ecliptic is the angle between the ecliptic and the equator. Its value, about $23\frac{1}{2}^\circ$, is the maximum distance which the Sun can reach north or south of the equator, i.e. the Sun's declination can vary between $23\frac{1}{2}^\circ$ N. and $23\frac{1}{2}^\circ$ S.

The Equinoxes are the points at which the ecliptic cuts the equator. When the Sun is at either of the equinoxes, it is on the equator and therefore rises and sets exactly in the east and west points. The lengths of day and night are then equal, hence the term equinox.

The Vernal Equinox (or *First Point of Aries*) is the point at which the Sun is passing from south to north of the equator. It is the origin for the measurement of right ascension (*see* § 6). The Sun is at the vernal equinox about March 21.

The Autumnal Equinox (or *First Point of Libra*) is the point at which the Sun passes from north to south of the equator. The Sun is at the autumnal equinox about September 23.

The terms vernal and autumnal equinox are also used to denote the times when the Sun crosses the equator.

The Solstices are the points on the ecliptic midway between the equinoxes. At these points the Sun attains its greatest north and south declinations and reaches its greatest and least altitudes in the heavens. It therefore stops moving in altitude or "stands" for a few days, hence the term solstice.

The Tropics are the two small circles on the celestial sphere which are parallel to the equator and pass through the solstices. The word means "turning" and it is when the Sun is on the tropics that its motion turns from northwards to southwards or *vice versa*. The path of the Sun lies between the tropics.

The position of a celestial body may be defined with reference to the ecliptic by co-ordinates analogous to right ascension and declination which define the position relatively to the equator. The *longitude* of a star is measured eastwards along the ecliptic from the vernal equinox to the foot of the great circle passing through the pole of the ecliptic and the

star. Or, in other words, it is the angle between the two great circles through the pole of the ecliptic passing through the vernal equinox and the star respectively. The *latitude* of a star is its distance north or south of the ecliptic measured along a great circle through the poles of the ecliptic.

23. **The Nature of the Earth's Orbit.**—A general idea of the shape of the orbit described by the Earth around the Sun may easily be obtained. From observations with the meridian circle, the position of the Sun on the celestial sphere at various times throughout the year may be determined, $S_1, S_2, S_3 \dots$ in Fig. 13.

To an observer on the Sun, the Earth would appear at the same times in the diametrically opposite directions $OE_1, OE_2,$ etc. If the positions of the points $E_1, E_2, E_3 \dots$ on their several radii can be found, both the shape and size of the orbit are determined. By simple methods it is possible to determine their positions on any arbitrary scale, but the determination of the true scale is a matter of some difficulty, the consideration of which will be deferred for the present. To determine the relative lengths it is only necessary to measure the values of the angular diameter of the Sun in the positions $S_1, S_2 \dots$ which can easily be done by projecting an enlarged image of the Sun upon a screen. The diameters can be determined either in arbitrary linear measure or, by computation from the dimensions of the apparatus used, can be expressed in arc.

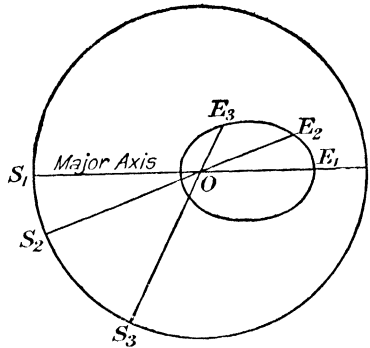

FIG. 13.—The Earth's Orbit.

If the observations are accurately made, it will be found that the angle subtended by the Sun is not constant throughout the year, but is greater in winter than in summer. Thus, the values of the Sun's semi-diameter at certain times of the year are approximately :

January 1 . . .	16' 18"	July 1 . . .	15' 45"
April 1 . . .	16' 2"	October 1 . . .	16' 0"

This variation is due, not to an actual change in the Sun's diameter, but to changes in the distance between the Earth and the Sun. The distance, in fact, must be inversely proportional to the angular diameter. If then, the points $E_1, E_2, E_3 \dots$ are chosen on the radii through O , so that their distances from O are inversely proportional to the angular diameters of the Sun at $S_1, S_2, S_3 \dots$, and the points so plotted joined by a curve, this curve will represent the shape of the orbit of the Earth around the Sun which is at the point O .

The curve so found is not quite a circle, being slightly oval in shape. It is an ellipse with the Sun in one of the foci. An

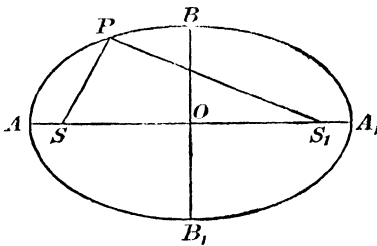

FIG. 14.—The Ellipse.

ellipse can be simply constructed by taking two points S and S_1 (Fig. 14), fixing the ends of a piece of cotton to these points by pins and running a pencil round inside the cotton, which is kept taut in the process. It is obvious that $SP + S_1P$ is constant for any point on the ellipse.

If A and A_1 are the points on the curve in SS_1 produced,

$$\begin{aligned} SP + S_1P &= SA + S_1A \\ &= SA + SA_1 \text{ (from symmetry)} \\ &= AA_1. \end{aligned}$$

AA_1 is called the major axis of the ellipse, S and S_1 are called its foci. A line BOB_1 through O , the mid-point of SS_1 and perpendicular to it, is called the minor axis.

The smallest value of the radius-vector SP , joining one of the foci to any point P on the curve, is SA , and the greatest value is SA_1 . The ratio of SO to OA is called the eccentricity. The larger the eccentricity the more the ellipse deviates from a circle, which is the limiting case of the ellipse when the foci SS_1 both coincide in the centre O . The eccentricity e can be expressed in terms of the lengths of the major ($2a$) and minor ($2b$) axes, viz. :

$$e = (a^2 - b^2)^{\frac{1}{2}}/a.$$

It must be carefully distinguished from the ellipticity referred to in § 13, which is equal to $(a - b)/a$, and which is a much smaller

quantity. Thus the eccentricity of the Earth's orbit is about $1/60$, its ellipticity about $1/7200$.

For an ellipse of small eccentricity, the ellipticity is $\frac{1}{2}e^2$.

If the Sun is at the focus S , then the Earth is at the point A (the end of the major axis nearest this focus) on January 1, and at the other end A_1 , six months later, on July 3. These positions are called *perihelion* and *aphelion* respectively. The Earth is therefore nearer the Sun in winter than in summer. When the Earth is at perihelion with respect to the Sun, the Sun is said to be at *perigee*, with respect to the Earth; when the Earth is at aphelion, the Sun is at *apogee*.

24. The Motion of the Earth in its Orbit.—If the Earth's orbit as so determined be carefully plotted on squared paper and the position of the Earth at various intervals be marked, then by drawing the radii from the focus occupied by the Sun to these positions and counting the squares included between consecutive radii and the ellipse, the relative areas described by the Earth's radius-vector in various times will be determined. It will be found that the areas swept out are directly proportional to the times or, in other words, in equal times equal areas will be swept out. This is one of Kepler's laws of planetary motion, which will be referred to in § 116.

Thus in Fig. 15, if the Earth moves from E_1 to E_2 in the same time as from E_3 to E_4 , the area bounded by SE_1 , SE_2 and the curve is equal to that bounded by SE_3 , SE_4 and the curve. If the earth is nearer the Sun at E_1 , E_2 than at E_3 , E_4 , it follows that the arc E_1E_2 must be greater than the arc E_3E_4 . Therefore the Earth moves faster when near perihelion than when near aphelion.

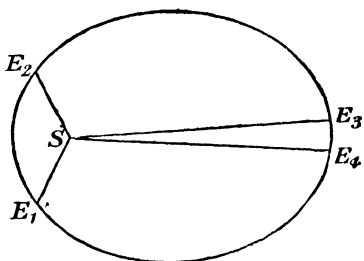

FIG. 15.—The Motion of the Earth in its Orbit.

25. Diurnal Phenomena Connected with the Earth's Motion.—We can now proceed to show how the information we have gained as to the motion of the Earth around the Sun will enable us to explain various phenomena connected with

the rising and setting of the Sun, the length of the day, and the duration of twilight and also phenomena connected with the seasons. The diurnal phenomena will be dealt with first.

For this purpose, the Sun may be considered as a star of variable declination. At the vernal equinox, the Sun is just passing from south to north of the equator. Its declination is therefore zero, but gradually increases day by day until the summer solstice, when it reaches its greatest value, $23^{\circ} 27' N.$, this value being equal to the obliquity of the ecliptic. From then onwards, the declination decreases until it is again zero at the autumnal equinox, when the Sun is passing from north to south of the equator. Between the autumnal equinox and the winter solstice, the south declination of the Sun increases from zero to its maximum, $23^{\circ} 27' S.$, after which it again decreases until the Sun crosses the equator northwards at the next vernal equinox.

The change in the Sun's declination is most rapid at the equinoxes, when it amounts to nearly $24'$ per day, and is least rapid at the solstices, when it is only a few seconds of arc per day. The rate of change is sufficiently slow to justify the assumption, in dealing with the diurnal phenomena, that the declination remains constant during one day, but changes from day to day.

It has been shown in § 5 that at the equinoxes, the Sun, being on the equator, rises in the east point and sets in the west point, and that this is true whatever the latitude of the place of observation. The diurnal path of the Sun is then a great circle (the equator), of which exactly one half is above and one half below the horizon and the lengths of day and night are equal. As the Sun moves north of the equator, its diurnal path becomes a small circle, and, since the north polar distance of the Sun is then less than 90° , it is evident that at places in the northern hemisphere more than half the path is above the horizon and that the intersections of the path with the horizon are north of the east and west points. Between the vernal and autumnal equinoxes, therefore, the Sun rises to the north of east and sets to the north of west, so that the length of the day is longer than the length of the night, for places in the northern hemisphere. Obviously, for places in the southern hemisphere, the converse holds, night being longer than day. The length of day attains its maximum value at the summer solstice.

For places on the equator (since for such places the Poles are on the horizon), the diurnal circles of the Sun's motion all cut the horizon at right angles and the lengths of day and night are then always equal. The Sun always rises about 6 a.m. and sets about 6 p.m.

In § 5, it was also shown that at any place, those stars whose north polar distances are less than the latitude of the place will never set. It follows that at the summer solstice, when the Sun's declination is about $23\frac{1}{2}^\circ$, at all places north of north latitude $66\frac{1}{2}^\circ$ the Sun will not sink below the horizon and there is no night, the Sun being visible at midnight. At all places south of south latitude $66\frac{1}{2}^\circ$, the Sun will not, at the same season, appear above the horizon. The two parallels of north and south latitude $66\frac{1}{2}^\circ$ are called the *arctic* and *antarctic circles* respectively. The higher the latitude, above $66\frac{1}{2}^\circ$, the longer will be the period during which the Sun does not sink below or rise above the horizon, and at the Poles themselves, since the horizon then corresponds with the equator, the Sun will remain above the horizon for six months continuously and will then disappear below the horizon for six months.

A reference to Fig. 2 shows that the meridian altitude of the Sun, SR , equals $SP - PR$ or $(180^\circ - \phi) - (90^\circ - \delta)$ or $90^\circ - \phi + \delta$, where δ is the declination of the Sun, ϕ the latitude of the place of observation. If $\phi > \delta$, the meridian altitude is less than 90° , and in that case the Sun will cross the meridian to the south of the zenith. If $\phi = \delta$, the Sun will pass through the zenith. This is possible only if ϕ is not greater than $23\frac{1}{2}^\circ$. At places on the two parallels of north and south latitude, $23\frac{1}{2}^\circ$, the Sun just reaches the zenith, but does not pass to the north or south of it respectively. At all places between these parallels, δ becomes at two periods of the year greater than ϕ , and at such places the Sun will pass at some periods of the year to the north of the zenith and at other periods to the south. The parallel of $23\frac{1}{2}^\circ$ north latitude is called the *Tropic of Cancer*, because the Sun is overhead near the summer solstice when the Sun is in the sign of the zodiac called Cancer. Similarly the parallel of $23\frac{1}{2}^\circ$ south latitude is called the *Tropic of Capricorn*, the Sun being overhead when in the sign of Capricorn.

At places whose north (south) latitude is greater than $23\frac{1}{2}^\circ$

the Sun is always to the south (north) of the zenith, but, in the northern hemisphere, its midday altitude is greatest at the summer solstice and least at the winter solstice, the reverse holding in the southern hemisphere.

26. Duration of Twilight.—If the Earth possessed no atmosphere, darkness would follow immediately upon sunset. The effect of the reflection and scattering by the Earth's atmosphere is to cause some illumination to reach the observer before sunrise and after sunset, this phenomenon being known as twilight.

No precise measure of the duration of twilight can be made. It is, however, found that no perceptible twilight remains after the Sun has sunk an angular distance of 18° below the horizon. The time taken by the Sun to sink this distance can therefore be used as a convenient measure of the duration of twilight. This time depends upon the angle at which the Sun's diurnal circle cuts the horizon; the more acute the angle, the greater the distance the Sun must travel in its path before it has sunk 18° below the horizon and therefore the longer twilight will last. On the equator, the diurnal circles cut the horizon at right angles and the duration of twilight is considerably less than in higher latitudes. In high latitudes also, there is a marked seasonal variation, twilight being longest at the summer solstice and least at the equinoxes.

27. The Seasons.—The Earth completes one revolution in its orbit round the Sun in a period of one year, passing perihelion on January 1 and aphelion at the middle of the year. The ecliptic is divided into four equal parts by the two equinoctial and the two solstitial points and the periods taken by the Sun in apparently traversing from one of these points to the next are called the seasons. Owing to the varying velocity of the Earth in its orbit, the lengths of the four seasons are unequal. This will be made clearer by a reference to Fig. 16, which shows the orbit of the Earth with the Sun in one of the foci S . The positions of perihelion P , and aphelion A are at the two ends of the major axis of the ellipse. If $S\Upsilon$ is the direction from the Sun to the First Point of Aries and two lines are drawn at right angles through S , one of which passes through

φ , these lines will intersect the orbit in the points designated φ , \simeq and M, N . Since the Sun is in the First Point of Aries at the vernal equinox, the Earth must then be at \simeq . It will be at φ six months later, at the autumnal equinox. It will similarly be at N at the summer solstice and at M at the winter solstice. The orbit is described in the direction $M \simeq N \varphi$.

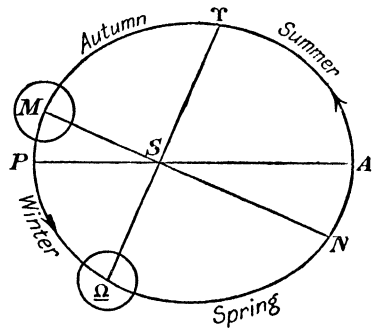

FIG. 16.—The Seasons.

The Earth is at perihelion P at the end of the year and the portion of the orbit from M to \simeq corresponds to winter, that from \simeq to N to spring, that from N to φ to summer and that from φ to M to autumn. It is evident that the areas $MS\simeq$, $MS\varphi$, $NS\simeq$, $NS\varphi$ are unequal, but that they increase in this order. In § 24 it was stated that the Earth moves in its orbit so that the rate of description of areas included between the curve and radii vectors to the Sun is constant. It follows that the times taken in describing these four areas increase with the areas or that, in other words, the seasons are of unequal length, winter being the shortest, autumn slightly longer, spring longer still and summer the longest of all. As a matter of fact, the approximate durations are :—

Spring	92 days 21 hours.
Summer	93 „ 14 „
Autumn	89 „ 18 „
Winter	89 „ 1 „

These statements are correct for the northern hemisphere. For any place on the Earth, the definition of summer as that period of the year taken by the Earth to pass from the point N to the point φ of its orbit is not correct, as summer is strictly that one of the seasons which has the highest average temperature. For places in the southern hemisphere, therefore, summer corresponds to the portion $M\simeq$ of the orbit autumn to the portion $\simeq N$, winter to the portion $N\varphi$ and spring to the portion φM . It follows that in the southern hemisphere

autumn and winter are of longer duration than spring and summer.

The variation in the heat received from the Sun to which the seasons owe their importance, is due to the axis about which the Earth rotates not being perpendicular to its orbit. We have seen indeed that the Earth's orbit lies in the ecliptic and that this is inclined at an angle of about $23\frac{1}{2}^{\circ}$ to the Earth's equator. The axis of rotation of the Earth, being perpendicular to the equator, is therefore inclined at an angle of $23\frac{1}{2}^{\circ}$ to the direction normal to its orbit. Further, this axis always remains parallel to itself as the Earth passes round the Sun, for the north polar distances of stars remain constant throughout the year, except for certain minute changes arising from

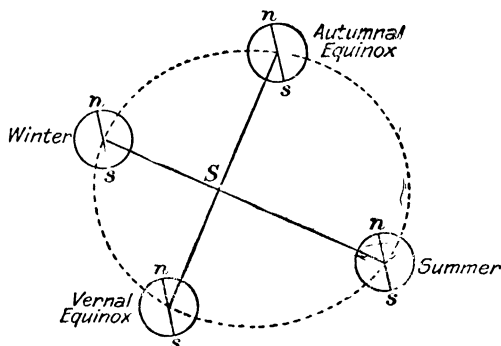

FIG. 17.—The Inclination of the Earth's Axis to Ecliptic.

other causes. The direction of the axis is always towards the pole of the equator and is therefore at right angles to the direction $\varphi \simeq$, this direction being that of the intersection of the equator and ecliptic. At the solstices and equinoxes, the directions of the axis are shown in Fig. 17. It will be seen from an inspection of the figure that in winter time the north end of the axis points away from the Sun, the Sun then being below the celestial equator, whilst in summer, it is the south end which points away, the Sun then being above the celestial equator. This is represented in a different manner in Fig. 18. A is any point in the northern hemisphere which has the Sun on its meridian, AS the direction to the Sun. O is the centre of the earth, so that OA is the direction of the zenith at A . In winter time the angle between AS and AZ is greater than in summer, i.e. the zenith distance of the Sun is greater or its altitude is less in winter than in summer. This has already been shown otherwise in § 25.

Combining the two effects, whose magnitudes may be obtained by calculation, it is found, as illustrated in Fig. 23, that the equation of time vanishes four times in a year, on or about April 15, June 15, August 31 and December 24. Its maximum positive value is nearly $14\frac{1}{2}$ minutes about February 12 and its maximum negative value is nearly $16\frac{1}{2}$ minutes about November 3. In the figure, the thin lines represent the two separate components, the thick line the combined equation

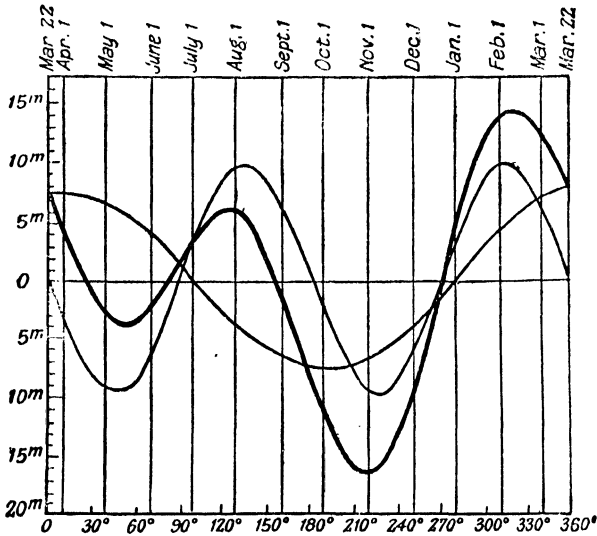

FIG. 23.—The Composition of the Two Components of the Equation of Time.

obtained by adding algebraically the ordinates of the two curves. At the bottom of the figure are given the solar longitudes, at the top the day of the year.

30. One or two consequences of the mean Sun being sometimes in advance and sometimes behind the true Sun may be noted in passing.

If mean noon always coincided with apparent noon, then the interval between sunrise and noon would be equal to the interval between noon and sunset. Expressed otherwise, if the times of sunrise and sunset are given in civil reckoning (a.m. and p.m.) the sum of the numbers would be 12 h. 0 m. This is not, in general, the case. At Greenwich the Sun rises,

for instance, on February 9 at about 7 h. 29 m. a.m. and sets at 5 h. 1 m. p.m., the sun being 12 h. 30 m. On November 2, on the other hand, sunrise is at 6 h. 55 m. a.m., sunset at 4 h. 31 m. p.m., the sun then being 11 h. 26 m. These differences are due to the varying sign and magnitude of the equation of time. For the Sun is due south at apparent noon and it may be assumed that the declination does not vary during one day ; it therefore follows that when the equation of time is positive the interval between mean noon and sunset will be longer than that between sunrise and mean noon by twice the amount of the equation of time ; when, on the other hand, the equation of time is negative, the former interval is shorter than the latter by twice its amount.

Another phenomenon well known in high latitudes is that the times of latest rising and earliest setting of the Sun do not occur on the shortest day. In such latitudes, the latest sunrise occurs some days after the winter solstice, the maximum difference being about 3 minutes. This is due to the change in the equation of time from day to day. Near the end of the year, the equation of time is increasing daily at the rate of about 30 seconds per day. In an interval of one week, therefore, it increases nearly 4 minutes. Neglecting for the moment, therefore, the variation in the declination of the Sun and the resultant change in the times of sunrise and sunset, it follows that after one week the Sun rises and sets 4 minutes later than at the beginning. This change, combined with the normal change due to the varying declination, produces the observed phenomenon.

The rate of change of the equation of time is of importance in another respect. It obviously provides a measure of the excess of the length of the true day (measured from one apparent noon to the next) over that of the mean day. This excess has its greatest positive value (about 28 seconds) near the winter solstice and its greatest negative values (about 20 seconds) near the two equinoxes. There is a smaller positive maximum of about 12 seconds near the summer solstice. The two days have equal length near the middle of February, the middle of May, the end of July and the beginning of November.

31. Local Time and Standard Time.—We have up to

the present been concerned with *local mean* and *local apparent time*. Local mean noon at any place is the moment of passage of the mean Sun across its meridian and similarly for local apparent noon. At two places, not situated on the same meridian of longitude, the times of local mean and also of local apparent noon will be different. The difference in time will obviously be the time equivalent of the longitude difference. Thus at a place whose longitude is l degrees east of Greenwich, local mean noon will occur $\frac{1}{15} l$ hours before Greenwich mean noon. This variation in the time of noon becomes of great importance in view of the rapidity of modern transport; if local mean time were everywhere adhered to innumerable difficulties would result, as it would be far from easy for accurate time to be kept. In order to avoid these difficulties, a system of standard or zone time has been adopted by most of the principal countries of the world. Under the zone system, the same time is adopted over the whole of the region on the Earth comprised between two meridians of longitude corresponding to a longitude difference of 15° , the time corresponding to that of the central meridian of the zone. At the boundaries of the zone the time changes abruptly by one hour. The first zone is comprised between longitudes $7\frac{1}{2}^\circ$ E. and $7\frac{1}{2}^\circ$ W. of Greenwich and throughout it Greenwich time is used. In successive zones east of Greenwich, the times are one, two, three . . . hours fast on Greenwich, and in the zones west of Greenwich the times are one, two, three . . . hours slow on Greenwich. Thus the same time is used over a wide area, but this time never differs by more than 30 minutes from local time. Occasionally the zone boundaries deviate slightly from the meridians, when simplification results from such deviation: e.g. if on the seaboard of a country, a small area only lies in one zone, it is convenient to bend the boundary of the adjacent zone so as to include such region. Several examples of this may be seen in Fig. 24, which shows the boundaries of the time zones at sea and along the sea-coast.

The 180th meridian from Greenwich is called the *date line*. Proceeding eastwards from Greenwich the time in the 12th zone will be 12 hours fast on Greenwich, whilst proceeding eastwards the 12th zone will be 12 hours slow on Greenwich. There is therefore a discontinuity of 24 hours in this zone.

Fig. 24.—Map showing the System of Time Zones and the Date Line, and Table giving Time now in use in Various Countries. [Differences from G.M.T.: Fast + : Slow —.]

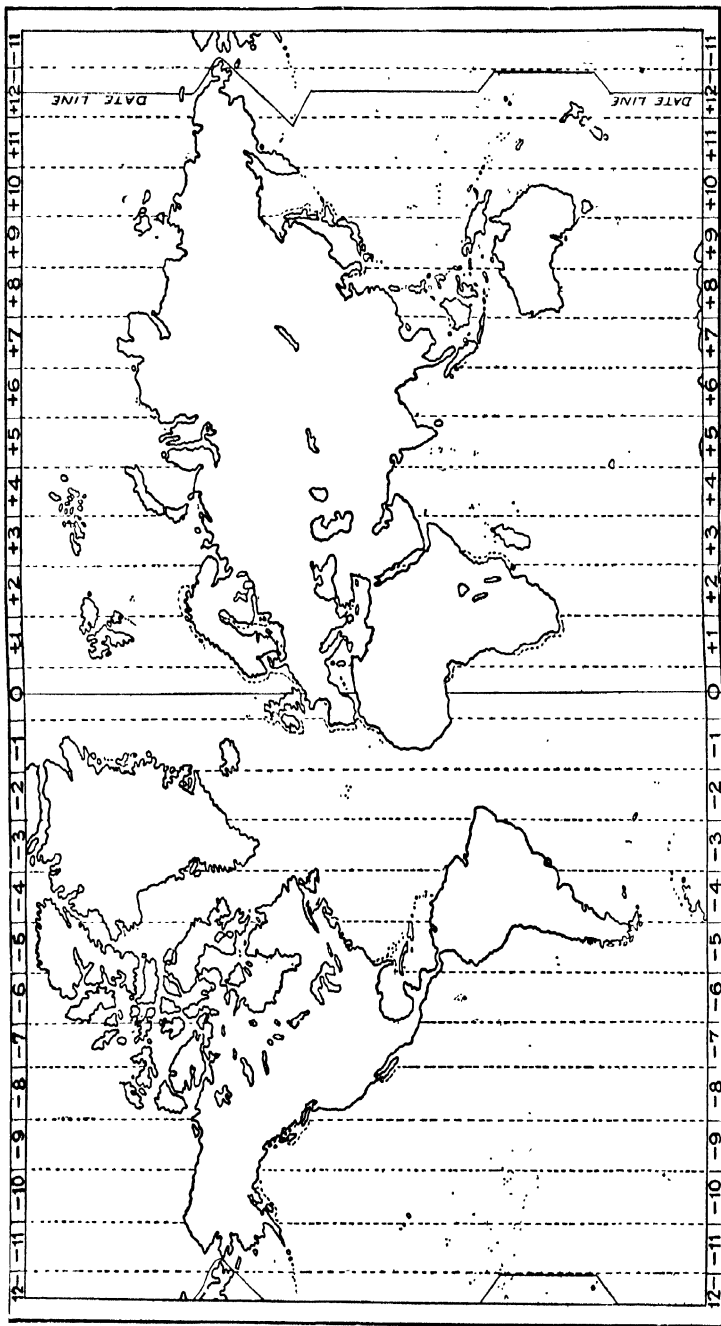

Alaska	. - 9 hours	Formosa	. + 8 hours	Martinique		Queensland	. + 10 hours
Algeria	. + 1 hour	France	. G.M.T.	W.I.	. - 4 hours	Réunion	. + 4 "
Angola	. + 1 hour	French Equatorial Africa	. + 1 hour	Mauritius	. + 4 "	Roumania	. - 2 "
Argentina	. - 4 h. 16 m. 48.2 s.	French		Mexico	. - 6 h. 36 m. 46.7 s.	St. Lucia, W.I.	. - 4 "
Ascension	. - 0 h. 57 m.	French		New Brunswick (E. of Campbell)		St. Pierre and Miquelon	. = 4 "
Austria	. + 1 hour	Guiana	. - 4 hours	ton)	. - 4 hours	St. Vincent	
Azores	. - 2 hours	Guinea	. - 1 hour	(W. of Campbellton)	. - 5 "	Samoa	. - 11 h. 23 m.
Bahamas	. - 5 hours	Indo China	. + 7 hours	New Cale		San Thorne Island	. G.M.T.
Belgium	. G.M.T.	Somali land	. + 3 hours	donia	. + 11 "	Salvador	. - 5 hr. 56 m. 32.0 s.
Brazil	. - 3 to 5 hours according to longitude	Germany	. + 1 hour	New Guinea	. + 10 "	Senegal	. - 1 hour
British Columbia	. - 8 hours	Gibraltar	. G.M.T.	New South Wales	. + 10 "	Serbia	. + 1 "
" Hon-		Gold Coast	. G.M.T.	Netherland	. + 11 h. 30 m.	Seychelles	. + 4 hours
" duras.	. - 6 hours	Greece	. + 2 hours	Nicaragua	. + 0 h. 19 m. 32.1 s.	Sierra Leone	. - 1 hour
" N. Borneo	. + 8 "	Grenada, W.I.	. - 4 "	Nigeria	. + 0 h. 30 m.	South Aus-	
" Burma	. + 6 h. 30 m.	Guadeloupe, W.I.	. - 4 "	Norway	. + 1 hour	tralia	. + 9 h. 30 m.
Cape Verde		Hawaiian Is.	. - 10 h. 30 m.	Nova Scotia	. - 4 hours	Society Islands	. - 10 hours
Islands.	. - 2 hours	Iceland	. - 1 hour	Panama Canal		Spain	. G.M.T.
Caroline Is.	. + 10 "	India (except Calcutta)	. + 5 hr. 30 m.	Peru	. - 5 "	Straits Settlements	. + 7 hours
Ceylon	. + 5 h. 30 m.	Italy	. + 1 hour	Philippine Islands	. - 5 "	Sweden	. + 1 hour
Chile	. - 4 hours	Italian Somaliland	. + 3 hours	Portugal	. + 8 "	Tasmania	. + 10 hours
China	. + 8 "	Ivory Coast	. G.M.T.	Portuguese E. Africa	. + 2 hours	Timor	. + 8 "
Colombia	. - 4 h. 56 m. 52.4 s.	Jamaica, W.I.	. - 5 hours	" Guinea	. - 1 hour	Tobago, W.I.	. - 4 "
Congo Free State	. + 1 hour	Japan	. + 9 "	India	. + 5 hours	Trinidad, W.I.	. - 4 "
Costa Rica	. - 5 h. 36 m. 16.9 s.	Korea	. + 9 hours	Prince Edward Island	. - 4 "	Tunis	. + 1 hour
Cyprus	. + 2 hours	Leeward Islands, W.I.	. - 4 "	ward Rico	. - 4 "	Turkey	. + 2 hours
Dahomey	. G.M.T.	Liberia	. - 1 hour	Quebec (E. of Pte. des Mons)	. - 4 "	Union of S. Africa	. + 2 "
Denmark	. + 1 hour	Madagascar	. + 3 hours	(W. of Pte. des Mons)	. - 4 "	United Kingdom	. G.M.T.
Ecuador	. - 5 h. 14 m. 6.7 s.	Madeira	. - 1 hour	des Mons)	. - 4 "	United States	. - 5 to 8 hours according to longitude
Egypt	. + 2 hours	Malta	. + 1 "	des Mons)	. - 4 "	Uruguay	. - 3 h. 44 m. 48.9 s.
European Russia	. + 2 h. 1 m. 18.6 s.	Marquesas Islands	. - 10 hours	des Mons)	. - 5 "	Venezuela	. - 4 h. 30 m.
Færøe Islands	. G.M.T.	States	. + 7 hours			Victoria	. + 10 hours
Fed. Malay States	. + 7 hours					West Aus-	
						tralia	. + 8 "

The date line runs through the middle of the zone. Between $172\frac{1}{2}^{\circ}$ E. long. and the date line, the time is 12 hours fast on Greenwich. Between $172\frac{1}{2}^{\circ}$ W. and the date line, it is 12 hours slow on Greenwich. If, at Greenwich, it is midnight on the night of, say, August 20–21, the time carried by a ship approaching at that instant the date line from the west will be noon on August 21, but on one approaching it from the opposite direction it will be noon on August 20. On crossing the date line the date on the former ship will be changed to August 20, one day being thus repeated, and that on the latter to August 21, one day being thus missed out. Therefore, in going round the world eastwards, the number of days occupied on the journey will be one more than the number of days reckoned at the point of the commencement and finish of the journey, but each day on the journey will be less than 24 hours in length. If the journey is made, on the other hand, in a westward direction, the number of days taken will be one less than the number reckoned at the point of commencement, each day, however, being longer than 24 hours. This phenomenon was made the basis of Jules Verne's story entitled "Around the World in Eighty Days," in which the hero started out eastwards on his journey, and after the completion of the journey in, as he thought over 80 days, he found that he was a day ahead of the calendar and that the journey had been completed within the prescribed time. He had not, in fact, put his calendar back one day when the date line was crossed.

The system of time zones and the date line are shown in Fig. 24. It will be noticed that the date line does not coincide throughout its length with the 180th meridian, but that for local convenience it is deviated in the neighbourhood of land in several places.

32. Precession of the Equinoxes.—When defining sidereal time in § 28, it was pointed out that the length of the sidereal day was measured with reference to a hypothetical star, the First Point of Aries—or, in other words, the ascending node of the ecliptic. The length of day so determined will not be quite the same as that which would be obtained if an actual fixed star were to be chosen as the reference body, unless the First Point of Aries is fixed relatively to the stars. If the

ecliptic and equator are fixed in space, the First Point of Aries will be fixed relatively to the stars, but if not it should be possible to detect a difference in the length of the year when observations are made relatively to a star or to the First Point of Aries.

This difference was actually detected by the ancients in the following manner. Two methods were used by them to determine the length of the year. One method was by the use of the gnomon : if, for instance, a vertical pole is set up and the length of the shadow observed, it will be noticed that its shortest length on any given days occurs at the time of apparent noon, the Sun then being at the highest point of its diurnal path. If observations be made each day at noon, a gradual change in the length of the noonday shadow will be found ; the shadow will be shortest at the summer solstice when the Sun's declination is greatest, and longest at the winter solstice when the declination is least. By observation of these phenomena in two successive years the length of year can be found, though not with very great accuracy, since the Sun's declination changes so slowly near the solstices. But if the observations are continued over a large number of years, this inaccuracy will be so much reduced that a very exact value of the length of the year will be obtained. Since the equinoxes occur midway between the solstices, this value gives also the interval between two consecutive passages of the Sun through the vernal equinox or First Point of Aries.

The second method of determining the length of the year was by what was termed the heliacal risings of stars. A star is said to have a heliacal rising when it rises above the horizon exactly at sunrise. At any given place the heliacal rising of a bright star near the ecliptic will occur only once a year, on the date when the Sun in its passage around the heavens passes near that particular star. By successive observations of such risings, the length of the year, or the interval between two consecutive passages of the Sun past a fixed star, will be determined.

On determining the length of year by these two methods, a slight discordance in the two values was found. The former method gave a somewhat shorter year, indicating that the Sun, in its apparent motion round the heavens, passes more quickly

from the vernal equinox along the ecliptic back to the vernal equinox than it does from a given star and back to that star. The only possible interpretation of this result is that the vernal equinox is in motion relatively to the stars and this in turn means that either the ecliptic or the equator, or both, cannot be exactly fixed. It was discovered by Hipparchus, whose result has been confirmed, that the ecliptic is fixed on the celestial sphere, but that the equator is not : it has been found that, apart from slight variations due to the motions of the stars themselves, the distances of the stars from the ecliptic do not change, but that their declinations, or distances from the equator, show progressive changes. The equator therefore moves in such a way that the equinoxes move very slowly along the ecliptic, the direction of this motion being opposite to that of the Sun's motion. This phenomenon was called by Hipparchus the *Precession* of the equinoxes. In magnitude it is not very large, amounting to about 50" per year, though this causes a difference of 20 minutes in the lengths of the year, as determined by the two methods referred to above.

33. Physical Cause of Precession.—The physical cause of the phenomenon of precession is very simple. We have seen that the Earth is not quite spherical in shape, but that it is flattened at the poles, the polar diameter being less than the equatorial diameters. We may regard the Earth as being built up of a spherical portion whose diameter is equal to the length of the Earth's polar axis and of an outer shell whose thickness gradually decreases from the equator to the poles, where it vanishes. Since the bulge lies in the equator, it is inclined to the ecliptic.

The gravitational force between the Earth and the Sun would, if the Earth were a perfect sphere, merely hold it on its orbit. We may investigate the effect of the Earth's ellipticity by regarding the pull as being built up of two components, the pull on the spherical portion, which will act through the centre of the earth, and that on the outer shell. It is the latter which has significance in the explanation of precession. In Fig. 25 is shown a section through the Sun and the axis of the Earth at the time of winter solstice. The line to the Sun is the trace of the ecliptic, *O* is the centre of the earth ; *N*, *S* are the ends

of its axis of rotation, E_1, E_2 the ends of an equatorial diameter. Then the angle between OE_1 and the direction from O to the Sun is equal to the obliquity of the ecliptic. It is evident that E_1 is nearer the Sun than E_2 and that the attraction on the NE_1S portion of the outer shell is greater than that on the NE_2S portion, and there is, therefore, a mechanical couple tending to turn the equator of the Earth into the plane of the ecliptic. (The attraction on the spherical portion has no turning moment, since it passes through the centre.) If the Earth were not rotating, it would be turned in this sense until the equator coincided with the ecliptic: but actually it possesses turning moments about two axes at right angles.

viz. about its axis of rotation and about an axis passing through its centre at right angles to the axis of rotation and in the plane of the ecliptic. It can be shown, by the principles of elementary rigid dynamics,

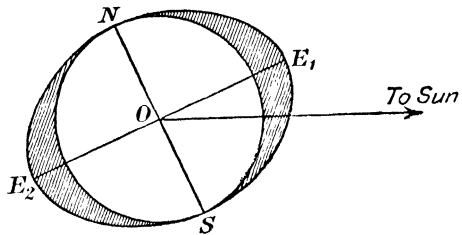

FIG. 25.—To illustrate Precession.

that under such circumstances a steady state of equilibrium can only be maintained when the axis of rotation rotates uniformly around the ecliptic in a backward direction, the mechanical effect of the change in space of the axis of rotation introducing a force couple which just balances that which is tending to turn the equator into the ecliptic.

This is simply illustrated by an ordinary gyrostat. If the gyrostat is spinning about its axis and a small weight is affixed to one end of the axis, or the finger pressed lightly upon it in a vertical direction, that end of the axis is not depressed, but the whole gyrostat will commence to rotate about a vertical axis, i.e. to precess.

The effect of the attraction is therefore to cause the pole of the equator to move in a small circle about the pole of the ecliptic, the radius of the circle being equal to the obliquity of the ecliptic, which remains constant.

The rate of rotation depends upon the relative magnitudes of the two force couples. That tending to turn the equator

into the ecliptic is very small compared with the angular momentum couple of the earth's rotation. The rate at which the earth precesses is therefore extremely slow. Since the precession in one year amounts to $50''\cdot2$, a complete rotation at this rate would occupy $360^\circ/50''\cdot2$ years or 25,800 years.

As a consequence of this precessional motion, it follows that Polaris, the Pole Star, which is at present only slightly more than 1° distant from the north pole of the equator and which serves as such a convenient guide to the position of the pole, has not always been near the pole. In the time of Hipparchus it was 12° distant from it, and about 13,000 years ago it was 47° distant. The distance at present is slowly decreasing and will continue to decrease to a minimum distance of about $30'$, after which it will again increase.

Another consequence of precession is that the First Point of Aries is now no longer in the constellation of Aries but in that of Pisces.

34. Variation in Precession.—The precessional motion, which was stated in the preceding paragraph to amount to $50''\cdot2$ in one year, is not uniform throughout the year. Evidently the magnitude of the couple exerted by the Sun tending to turn the equator into the ecliptic must depend upon the Sun's declination. When the Sun is crossing the equator, the couple vanishes; at the solstice, when the declination has its greatest values, the couple is at a maximum. In addition, superimposed upon the solar precession, is a precession arising from the attraction of the Moon, whose orbit is inclined at about 5° to the ecliptic. It is the sum of the two precessions which amounts on the average to $50''\cdot2$ annually. The lunar precession vanishes twice each month, when the Moon is crossing the equator. The value of the precession is therefore variable throughout the year, being very much greater at some periods than at others.

Even the annual value of the precession is not constant. This arises from another phenomenon. The orbit of the Moon meets the ecliptic in two points (the nodes) which themselves have a westward movement on the ecliptic; this movement is much more rapid than precession, one revolution being completed in slightly less than 19 years. At a certain stage in this

westward motion, the ascending node of the Moon's orbit will be at the vernal equinox and the angle between the Moon's orbit and the equator will then be about $28\frac{1}{2}^\circ$. After an interval of $9\frac{1}{2}$ years, the ascending node will have moved westwards to the autumnal equinox and the inclination will then only be $17\frac{1}{2}^\circ$. The lunar portion of the precession will therefore be much greater in the first position than in the second, as the couple tending to turn the equator increases with the inclination of the equator to the orbit. This is connected with the phenomenon of nutation.

35. Nutation.—Precession causes gradual changes in both the right ascension and declination of a star. The effect on declination is most easily seen. If a star has right ascension about 0 h., so that the star is near the vernal equinox, it is evident that the effect of the westward motion of the vernal equinox along the ecliptic is to increase the distance of the star from the equator, i.e. to increase its declination. The rate of increase is the component perpendicular to the equator of the motion of the equinox along the ecliptic. If the star has R.A. 12 h., its declination will decrease annually by the same amount. For stars, however, whose R.A.'s are 6h. or 18 h., precession has no effect on their declination since the movement of the equator does not in the case of such stars either increase or decrease their distance from the equator. The declination component of the precession is, in fact, dependent only upon the star's right ascension, being proportional to $\cos \alpha$. The effect of precession on right ascension, is somewhat more complicated, being dependent upon both the right ascension and the declination of the star.

It was first shown by Bradley that the changes in the declinations of the stars could not be explained by means of aberration (*see* § 36) and precession only. After separating out these effects, the careful and long continued observations made by Bradley revealed another motion, by which the pole of the equator is at some times before and at other times behind the position which it should occupy on the hypothesis of a uniform precessional motion in a small circle about the pole of the ecliptic and, in addition, the distance from this pole is sometimes greater and at other times smaller than its mean value.

Bradley was able to trace the origin of this motion by proving that it was periodic in nature with a period of about 19 years. This period has already been referred to: it is the period of revolution of the nodes of the Moon's orbit around the ecliptic. The phenomenon is known as *Nutation* or "nodding." The axis of the Earth, instead of describing a circle, moves in a slightly wavy curve, whose mean distance from the pole of the ecliptic remains constant. Each wave occurs in a period of about 19 years, so that there must be nearly 1,400 waves in the entire circumference.

The phenomenon of nutation is due physically to the existence of a small component of the attractive force with which the Moon tends either to accelerate or to retard the precessional motion.

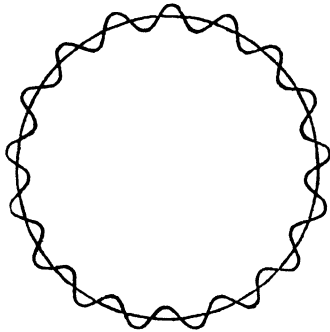

FIG. 26.—Nutation.

A general idea of the nature of the orbit of the pole of the equator around the pole of the ecliptic may be obtained from Fig. 26. In this figure, the size of the nutations are relatively much too great and their number too small.

36. Aberration.—Another phenomenon connected with the orbital motion of the Earth which produces changes in the right ascensions and declinations of stars is that known as *Aberration*, which, together with nutation, was discovered by Bradley in the eighteenth century.

When Bradley commenced his investigations, he was endeavouring to determine the distances of stars, which at that time were believed to be much nearer than we now know them to be. Bradley argued that if a star is at not too great a distance it should show an appreciable annual motion in the sky, and the nearer the star, the larger would be this motion. In fact, if a cone is formed with its vertex at the star and the orbit of the Earth round the Sun as its base, the apparent motion of the star due to its finite distance would be given by the section of this cone by the celestial sphere (whose radius is infinitely

great). The star should therefore appear to describe in the sky an ellipse of small angular diameter, the shape of this ellipse being similar to the projection of the Earth's orbit on the tangent plane to the celestial sphere at the point where the radius to the star meets it. The major axis of this ellipse will be parallel to the ecliptic and the star at any time will be at that point in the orbit which is opposite to the Earth.

As a suitable star to observe Bradley chose γ Draconis, which passed very near the zenith of his observatory and whose position was therefore practically unaffected by refraction. A special zenith telescope, now preserved at the Royal Observatory, Greenwich, was used. By careful observation, Bradley found an annual displacement of the star which was of the type which he had anticipated, except that the position of the star in its small orbit was only 90° from the position of the Earth in her orbit, instead of being opposite to it. This led Bradley to the discovery of the phenomenon of aberration.

Aberration is the apparent displacement of a star, arising from the fact that the velocity of light is not infinite compared with the orbital velocity of the earth. It can be simply explained by the parallelogram of forces. The simplest illustration is to imagine a train moving with uniform velocity whilst a shower of rain is falling vertically. To an observer in the train, facing the direction of motion, the rain drops appear to be falling slantwise towards

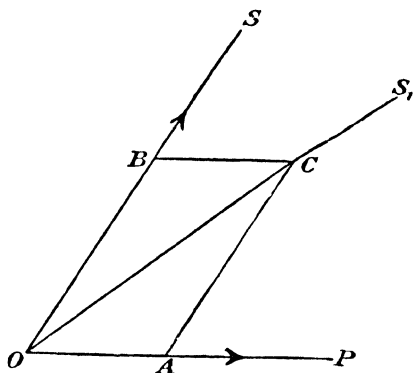

FIG. 27.—Aberration.

him, since their velocity relative to him is a combination of their velocity and the velocity of the train. If light consisted of material corpuscles, it is clear that in a precisely similar manner the apparent direction of the light coming towards us from a star is the direction of the resultant velocity of the light corpuscles and the earth. A similar result holds on the wave theory of light, although then it is not so self-evident.

If then, in Fig. 27, OP is the direction of motion of the Earth around the Sun, OS the direction to a star, and if OA , OB represent in magnitude the velocities of the Earth and of light, the apparent direction of the star is OC , the diagonal of the parallelogram $OACB$.

If θ is the small angle SOS_1 or OCA which measures the displacement, and α is the angle POS_1 , between the direction of the Earth's motion and the apparent direction to the star, and if c and v are respectively the velocities of light and of the Earth, the triangle OCA gives

$$\sin \theta = \frac{v}{c} \sin \alpha.$$

The angle, α , between the direction to the star and that of the Earth's motion, is called the *Earth's way*. Also since θ is small, we may replace $\sin \theta$ by θ , and the displacement is :

$$\theta = \frac{v}{c} \sin \alpha = \frac{v}{c} \sin (\text{Earth's way}).$$

It has thus been proved that all stars are at any instant apparently displaced towards that point of the heavens to which the Earth is at that instant moving. The amount of the displacement depends upon the angle between the Earth's line of motion and the direction to the star, being proportional to its sine. The constant $\left(\frac{v}{c}\right)$ of the proportion is called the *constant of aberration* and has a value of $20''.47$.

Now the direction of motion of the Earth is along the tangent to its orbit, which is in the plane of the ecliptic. Viewed from the Earth, this point on the celestial sphere is the point on the ecliptic which is 90° behind the Sun. The aberration at displacement of a star is therefore always towards the point on the ecliptic which is 90° behind the Sun. At the vernal equinox, the displacement is towards the winter solstitial point and so on.

In the case of a star situated at the pole of the ecliptic, the magnitude of the aberrational displacement is constant throughout the year, since the direction of the Earth's motion and the direction from the Earth to the star are always at right angles to one another. In the case of any other star, these directions are only at right angles at the two points on the orbit where a plane

through the star perpendicular to the ecliptic cuts the orbit. The displacement of the star is then parallel to the ecliptic and of amount $20''\cdot47$. At the two points on the orbit midway between these points, the direction of motion is parallel to the orbit and the displacement is along a great circle perpendicular to the ecliptic and of amount $20''\cdot47 \sin S$, where S is the star's latitude or distance from the ecliptic.

In general, the aberrational displacement is such that the star appears to move in an ellipse, whose major axis is parallel to the ecliptic; this ellipse is similar to the projection of the Earth's orbit on to the tangent plane to the celestial sphere at the star and is therefore similar to the ellipse which would be described on account of parallax if the star were relatively near. At any given time, however, the displacements of the same star due to parallax and to aberration are in directions which differ by 90° . There is the further difference that the magnitude of the parallactic displacement is dependent upon the distance of the star, but that of the aberrational displacement is not.

After Bradley had discovered aberration, he found certain other residual phenomena which required explanation. His observations showed that, after allowing for the effects of aberration and precession, the north polar distance of γ Draconis gradually decreased during the years 1728, 1729, 1730, 1731. Amongst other stars observed by Bradley was one in Camelopardalus with opposite right ascension to γ Draconis. Bradley found that, after allowing for the effects of aberration and precession in the case of this star, there was an equal and contrary change in north polar distance. This indicated a movement of the Earth's axis away from the one star and towards the other. By continuing his observations for many years more, Bradley was able to connect this "nutation" with the motion of the Moon, as already described, so completing an investigation which was a masterpiece of careful and patient observation.

37. Brief reference may be made to the effect of the attraction of the planets on precession and that of the rotation of the Earth on aberration.

Careful investigation shows that the distances of the stars from the ecliptic (i.e. their latitudes) are not absolutely constant

but show very slight changes. This indicates a slight motion of the ecliptic itself. The phenomenon arises from the attraction of the planets on the Earth, the effect of which is slightly to disturb its path. A gradual change in the obliquity of the ecliptic is thus produced: this is very small, amounting to a decrease of only about half a second per year. The change is oscillatory but with a very long period—many thousands of years. The attraction of the planets produces other slight disturbances in the Earth's orbit, the principal being a small change in the eccentricity, which is at present slowly decreasing, and a slow eastward revolution of the apses of the orbit (the points nearest to and farthest from the Sun).

In addition to the aberrational displacement referred to in the previous section, there is a further slight effect caused by the motion of the observer which has its origin in the Earth's rotation. This effect is known as *diurnal aberration*. The constant in the aberration formula is about $0''.3 \cos l$, l being the observer's latitude: it is thus greatest at the equator. The effect on the position of a star is greatest when the star crosses the meridian, and it then produces an increase in its apparent right ascension of amount $0''.3 \cos l \sec \delta$, δ being the declination of the star.

38. The Calendar.—A year being the period of revolution of the Earth about the Sun relative to a certain body of reference, the length of the year will vary according to the reference body chosen.

The natural unit marked out for the use of man is the period of revolution relative to the First Point of Aries, since this period determines the commencement of the seasons and all associated phenomena and ensures that these always take place at about the same date in each year. The year so defined is called the *Tropical Year*. It has been found by observation to consist of 365.242216 mean solar days. This is the year whose length was determined by the ancients by the use of the gnomon.

The period determined when the starting-point is a point fixed amongst the stars is called the *Sidereal Year*. This is the year determined by the heliacal risings of the stars. We have already seen that it is longer than the tropical year, owing to the

retrograde motion of γ , of $50''.22$ annually. In fact the tropical year : $360^\circ - 50''.22 =$ sidereal year : 360° .

A third year is obtained by taking as starting-point the perihelion of the Earth's orbit. In the previous paragraph, it was mentioned that the axis of the Earth's orbit has a slow eastward revolution ; this amounts to $11''.25$ annually. The *anomalous year*, as this period is called, is therefore longer than the sidereal year, since the Earth has to move through an additional $11''.25$ before completing one revolution relative to perihelion. Thus sidereal year : $360^\circ =$ anomalous year : $360^\circ + 11''.25$.

The lengths of the three years are :—

Tropical year	=	365.242216 days
Sidereal year	=	365.256374 ,,
Anomalous year	=	365.259544 ,,

In addition to these three kinds of year, there is the *Civil Year*, which consists of an exact number of days. It is, however, based upon the tropical year in the manner now to be described.

There are three natural units of time marked out by nature for the use of man, viz. the apparent solar day, the lunar month and the tropical year. The first of these may be replaced by the mean solar day, which it is necessary to introduce on account of the inequality in the length of the apparent solar day. The three periods are not commensurable amongst themselves. For civil purposes, it is necessary that the civil year should contain an exact number of days, as otherwise a portion of one day would fall in one year and the rest of it in the succeeding year, with obvious inconveniences.

It becomes necessary therefore to devise a calendar in which the civil year shall contain an integral number of days but such that the average length of the year shall be very nearly equal to the tropical year. Early calendars did not conform to this condition, being based mainly upon the lunar year of twelve lunar months. Such a calendar is still in use by the Moham-medans, but it suffers from the great disadvantage that the seasons fall in different months from year to year, the length of the year being only about $354\frac{1}{2}$ days. The Roman calendar was of a similar nature, but in order to keep the seasons correct, days or months were arbitrarily inserted. In order to avoid the

resulting and inconvenient confusion, the aid of an Alexandrian astronomer, Sosigenes, was called in by Julius Cæsar and it was to him that the ingenious suggestion of leap year is due. The so-called *Julian Calendar* was the result : three years of 365 days were to be followed by one year of 366 days, giving a mean length for the civil year of 365.25 days. This is .007784 days longer than the tropical year, a difference which only amounts in 400 years to somewhat over 3 days. The Julian calendar was introduced in the year 45 B.C. At the same time, the epoch of the commencement of the year was changed. It had previously commenced in March, but the date was now altered to January 1—the day of the new Moon following the winter solstice, 45 B.C. The year preceding the change was made unduly long and is known as the year of confusion.

The Julian calendar being in error by 3 days in 400 years, the error gradually accumulated in the course of centuries. The next step towards improvement was made by Pope Gregory XIII, on the advice of the Jesuit astronomer, Clavius, with a view to bringing the date of Easter nearer to the vernal equinox, since the date of Easter was gradually tending to come more and more into the summer. The *Gregorian Calendar* modified the Julian calendar by omitting certain leap years : all century years are excluded unless their date number is divisible by 400. Thus the year 1900 was not a leap year, but the year 2000 will be. The effect of this modification is to shorten the average length of year : in 400 years there will only be 97 leap years instead of 100, so shortening this period by 3 days, and thus practically accounting for the error of the Julian calendar. The average length of the civil year of the Gregorian calendar is 365.2425 days : this makes the average civil year too long by 0.000284 days, so that the amount of error is only 1 day in about 4,000 years. In the year 1582, when the change was adopted by Roman Catholic nations, the day following October 4 was called October 15, in order to adjust for the accumulated error. The Gregorian calendar was not adopted in Eng'and until the year 1752, when the difference between the two calendars had increased to 11 days. The day following September 2, 1752, was called September 14 ; at the same time, the beginning of the year was changed from March 25 to January 1.

In Russia the old style was adhered to until after the

Revolution and the difference was then 13 days. It had become customary before the change for both dates to be used for commercial and scientific purposes.

39. The Reform of the Calendar.—The division of the year into twelve unequal months is purely arbitrary and in this respect our present calendar suffers from many inconveniences. The first of January, or any other given date, occurs one day later in the week in any given year than in the preceding year, except in the case of leap year, when dates after February 29 occur two days in the week later. Also the quarters of the year are of unequal length. In order to avoid these and other similar disadvantages, various schemes for the reform of the calendar have from time to time been put forward. Of these the following scheme, first proposed by Armelin in 1887, is probably the simplest and has most to recommend it :—

The year is formed of four equal quarters with the addition of one or two supplementary days, according to whether it is an ordinary or a leap year. Each quarter consists of two months of 30 days each, followed by a third month of 31 days, there being therefore exactly 13 weeks in each quarter. The nominal year of 365 days consists of four identical three-monthly periods of 91 days, the first two periods being separated from the last two by an intermediary day, which is undated and is placed outside the week. It is proposed to call this day *Peace Day*. In leap years a second supplementary day is added at the end of the year and called *Leap Day*. A simple perpetual calendar is thus obtained :

{ 1st quarter	January.	February.	March.	
{ 2nd „	April.	May.	June.	
<i>Peace Day.</i>				
{ 3rd quarter	July.	August.	September.	
{ 4th „	October.	November.	December.	
<i>Leap Day</i> (in leap years only).				
For each quarter	Monday .	1 8 15 22 29	6 13 20 27	4 11 18 25
	Tuesday .	2 9 16 23 30	7 14 21 28	5 12 19 26
	Wednesday	3 10 17 24	1 8 15 22 29	6 13 20 27
	Thursday	4 11 18 25	2 9 16 23 30	7 14 21 28
	Friday .	5 12 19 26	3 10 17 24	1 8 15 22 29
	Saturday.	6 13 20 27	4 11 18 25	2 9 16 23 30
	Sunday .	7 14 21 28	5 12 19 26	3 10 17 24 31

Arranged in this way, the last day of each quarter is a Sunday, and this is the most suitable day to be followed by Peace Day and Leap Day which might conveniently be taken as Bank Holidays. The adoption of such a calendar would provide a suitable opportunity for fixing the dates of the movable religious festivals. The whole calendar could easily be carried in the memory. The principal objection advanced against the scheme is that the insertion of the supplementary days breaks the continuity of the week. The objection is not of very much weight, and unless the continuity of the week is broken, it is not possible to make the same dates always correspond to the same days of the week.

40. The Julian Date.—The Julian Date is a system of reckoning extensively employed in astronomical calculations for the purpose of harmonizing the various systems of chronological reckoning. The system was originally put forward in 1582 by Scaliger. The Julian Period consists of 7,980 Julian years of exactly $365\frac{1}{4}$ days: the starting-point or “Epoch” is 4713 B.C. January 1. The date of any phenomenon can be expressed without any ambiguity by the number of days which have elapsed since the Julian epoch and the interval in days between any two events can therefore be at once found when their Julian dates are known. The system is particularly convenient for expressing by a formula the dates of maxima and minima of a variable star. In the *Nautical Almanac* for any year is given the Julian year and day corresponding to January 1 for each year of the Christian Era. Thus:

At mean noon, 1920, Jan. 1, there have elapsed 2,422,325
Julian days.

At mean noon, 1921, Jan. 1, there have elapsed 2,422,691
Julian days.

At mean noon, 1922, Jan. 1, there have elapsed 2,423,056
Julian days.

41. The Metonic Cycle.—In connection with the calendar, reference may be made to the *Lunar Cycle of Meton*, discovered by him about 433 B.C. and still used in fixing the

dates of the movable religious festivals. The rule gives a simple relationship between the length of the lunar month and the tropical year and was used by the Greeks to predict the days on which their religious festivals, dependent on the phases of the Moon, should be celebrated. Meton found that after a lapse of 19 years, the phases of the Moon recurred on the same days of the same months. In fact, 19 tropical years, of 365.24222 days, equal 6939.602 days, whilst 235 synodic months (i.e. from new Moon to new Moon), of 29.53059 days, equal 6939.689 days. Hence, after 19 years, the mean phases of the Moon recur on the same days within about 2 hours. If the dates of full Moon are recorded during one cycle, they are therefore known for the following cycle. These dates were inscribed in letters of gold upon the public monuments and, for this reason, the number of a year in the Metonic cycle is called the *Golden Number*. The first year of a cycle may, of course, be chosen arbitrarily. The year 1 B.C. commences the cycle now in use and hence to find the golden number of a year, add 1 to the date number and divide by 19, then the remainder is the golden number: if the remainder is 0, the golden number is taken as 19.

Several rules have been put forward from time to time for the calculation of the date upon which Easter Day will fall in any year—Easter Day being the first Sunday after the full Moon which happens upon or next after the vernal equinox. Most of these rules are subject to various exceptions, but the following, first devised in 1876, is subject to no exceptions. The rule is as follows:—

Divide	By	Quotient	Remainder
The year x	19	—	i
“ “ “	100	b	c
b	4	d	e
$b + 8$	25	f	—
$b - f + 1$	3	g	—
$19a + b - d - g + 15$	30	—	h
c	4	i	k
$32 + 2e + 2i - h - k$	7	—	l
$a + 11h + 22l$	451	m	—
$h + l - 7m + 114$	31	n	o

Then n is the month of the year and $o + 1$ the number of the day of the month on which Easter falls.

E.g., to find the date of Easter Day in 1922, we have

$$\begin{array}{llll}
 a = 3 & b = 19 & c = 22 & d = 4 \\
 e = 3 & f = 1 & g = 6 & h = 21 \\
 i = 5 & k = 2 & l = 4 & m = 0 \\
 n = 4 & o = 15 & &
 \end{array}$$

Therefore Easter Day occurs, in 1922, on the 16th day of the 4th month, i.e. on April 16.

For a demonstration of the rule, reference may be made to Butchers' *Ecclesiastical Calendar*, p. 226.

CHAPTER IV

THE MOON

41. After the Sun, the Moon is to us the most important of the heavenly bodies. Her tide-raising force is of vital importance to mankind and her silvery light is always welcome at night. She is much the nearest of our celestial neighbours and therefore assumes an importance which would not otherwise be warranted by her size. Thus the Moon has been intimately associated with the progress and development of astronomy. Her motion round the Earth provided Newton with an approximate verification of his law of gravitation ; the detailed study of her motion has served to vindicate that law to a very high degree of accuracy and has occupied the best parts of the lives of several famous astronomers. The study of eclipses and of the tides have each raised many new problems and developed into important branches of astronomy, whilst theories of the formation of the Earth-Moon system are closely related to general theories of cosmogony.

42. **Apparent Motion of the Moon.**—The phenomena connected with the apparent motion of the Moon are much more easily observed than are the corresponding phenomena in the case of the Sun : not only is the apparent motion of the Moon much more rapid, but also the background of bright stars is easily visible, relative to which the motion may be observed. When the Moon is in the neighbourhood of a bright star or planet, her eastward motion amongst the stars can be seen during the course of a single night. It is also evidenced by the large retardation in the time of rising of the Moon from night to night.

Owing to the eastward motion of the Moon amongst the stars being much more rapid than that of the Sun, the Moon is

continually overtaking and passing the Sun. In fact, whilst the average daily angular motion of the Sun relative to the stars is only about 1° , that of the Moon is about 13° . When the Moon overtakes the Sun it is said to be in *conjunction*. This occurs when the longitudes of the Sun and Moon are equal. When their longitudes differ by 180° , the Sun and Moon are said to be in *opposition*. Both at conjunction and at opposition, the Sun, Earth and Moon are practically in one straight line, but whereas at conjunction the Moon is between the Earth and the Sun, at opposition the Earth is between the Moon and the Sun. When the longitudes differ by 90° , the Sun and Moon are said to be in *quadrature*.

The *sidereal revolution* of the Moon is the period occupied by the Moon in passing from a given star back again to the same star. Its average length is about 27 d. 7 h. 43 m. 11.6 s., or 27.32166 days, but varies from revolution to revolution on account of the various perturbing forces which may increase or decrease the interval by several hours.

The period naturally associated with the Moon, however, is its period of revolution with regard to the Sun, since it is this period which controls the phases. A *lunar month* may be defined as the period from new Moon to new Moon, or from full Moon to full Moon, i.e. from conjunction to conjunction, or from opposition to opposition. This period is also known as the *Synodic revolution*. It is longer than the sidereal period, on account of the eastward motion of the Sun amongst the stars which must be overtaken. Its mean length is 29 d. 12 h. 44 m. 2.87 s. or 29.53059 days. Its actual length may vary considerably from this mean value (the total variation is about 13 h.) on account of the eccentricities and perturbations of the orbits of the Moon around the Earth and of the Earth around the Sun.

Another period which may be mentioned is the *tropical period*, i.e. the period of revolution relative to the First Point of Aries. Owing to the slow retrograde motion of φ , this period is very slightly shorter than the sidereal period, the actual difference being about 6.85 seconds. The tropical period is 27.32158 days.

The sidereal and synodic periods of revolution are connected with the length of the sidereal year. The mean daily motion of the Moon relative to the Sun is equal to the difference

between its mean daily motion relative to the fixed stars and the mean daily motion of the Sun relative to the fixed stars. Since the daily motion is inversely proportional to the period of a complete revolution it follows that, if all the periods are expressed in days,

$$\frac{1}{\text{sidereal revolution}} - \frac{1}{\text{synodic revolution}} = \frac{1}{\text{sidereal year}}.$$

If the apparent diameter of the Moon is measured at different times, it will be found to vary only within narrow limits. The distance of the Moon from the Earth is therefore approximately constant; measurement has shown that the mean distance is about 238,000 miles or about sixty times the Earth's radius. The Moon is therefore a companion of the Earth in its annual motion around the Sun.

43. Phases of the Moon.—The most striking phenomenon connected with the Moon is its waxing and waning, i.e. the variation of its visible outline, to which we give the name of *phases*. The explanation of these phases is very simple. The Moon is not self-luminous like the Sun, but owing to the high reflecting power of its surface it is able to reflect back some of the light from the Sun

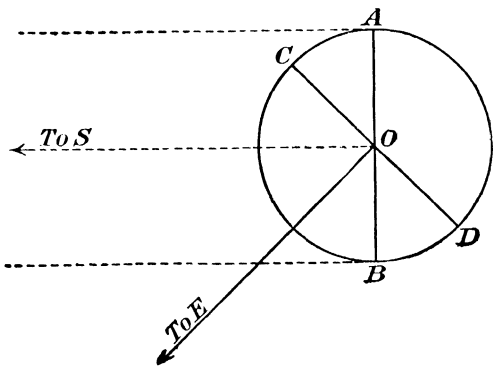

FIG. 28.—Explanation of Phases of Moon.

which falls upon it and it is by means of the light reflected from that portion of the surface which is illuminated by the Sun that the Moon becomes visible to us. In general, only a portion of this illuminated surface is visible from the Earth and to the variation of the amount visible with change of the relative positions of the Earth, Moon and Sun is due the phenomenon of the phases.

In Fig. 28, suppose $ACBD$ represents a section of the Moon in the plane containing the Earth and the Sun, O is the centre

of the Moon and OS , OE are the directions towards the Sun and Earth respectively at any time. Then the hemisphere whose trace by the plane of the paper is ACB , AB being perpendicular to OS , is illuminated by the Sun, whilst the hemisphere CBD , CD being perpendicular to the direction OE , faces the Earth. The only portion of the lunar surface therefore visible to the Earth is a lune, symmetrical about the plane SOE , whose trace is CB . What then is the shape of the portion of the Moon's surface actually visible under these circumstances? Referring to Fig. 29, $PCQD$ represents the hemispherical portion of the Moon's surface facing the Earth,

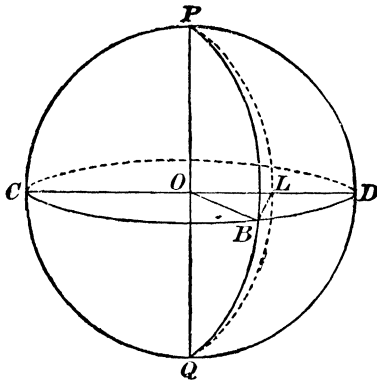

FIG. 29.—Shape of Visible Lunar Crescent.

O is the Moon's centre and the great circle PBQ forms the boundary between the parts of the surface which are illuminated by the Sun and the parts which are not illuminated. This bounding circle will appear in projection on the plane $PCQD$ as a semi-ellipse PLQ , in which L is the foot of the perpendicular BL drawn from B on to CD . The semi-axes of this ellipse are OP , the Moon's radius and OL . The latter is equal to

$OB \cos BOD$ or to $OB \cos SOE$ (Fig. 28), i.e. to the radius of the Moon multiplied by the cosine of the angle subtended by the Sun and Earth at the centre of the Moon. The semicircle PCQ forms the other bounding surface of the illuminated portion of the surface visible from the Earth. The apparent outline of the Moon is therefore formed of a semicircle and a semi-ellipse, the semicircle portion being the boundary facing the Sun: the common diameter of the semi-ellipse and the semicircle is perpendicular to the plane containing the Sun, Earth and Moon.

A portion of a sphere, such as $PCQBP$, intercepted by two great circles, is called a *lune*, the angle of the lune being COB . This angle is $180^\circ - BOD$ and is the angle between the directions from the Earth to the Moon and Sun respectively. The

visible portion of the Moon's surface is therefore a lune whose angle is equal to the angle subtended by the Sun and Moon at the Earth.

When the Earth is between the Sun and the Moon the angle BOD becomes zero. In that case the whole of the illuminated surface is visible and the Moon appears as a complete circle. This is called *full Moon* and occurs therefore when the Sun and Moon are in opposition. After opposition, as the angle SOE gradually increases, the illuminated visible portion of the Moon's surface correspondingly decreases. After an interval of one quarter of the lunar month, the angle SOE will be a right angle and then the minor axis of the elliptical portion of the boundary, PLQ , vanishes and the ellipse becomes a straight line POQ . At quadrature, therefore, the Moon appears as an illuminated semicircle. This is called the *last quarter*. The illuminated area continues to decrease until at conjunction, when the Moon is between the Sun and the Earth, only the unilluminated hemisphere faces the Earth and the Moon becomes invisible. This is called *new Moon* and occurs at an interval of half a lunar month after full Moon. After new Moon the bright area gradually increases again, becomes a semicircle at the next quadrature, when it is called *first quarter*, and a complete circle at the next full Moon.

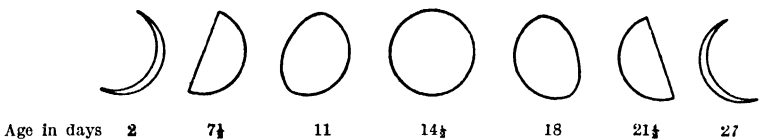

FIG. 30.—Successive Phases of Moon.

The successive appearances of the Moon from new Moon to new Moon are shown in Fig. 30.

The *age of the Moon* is the time, expressed in days, that has elapsed since the previous new Moon. Plate 1 (a) shows the Moon at the age of 12 days.

The elliptical portion of the boundary PLQ is called the *terminator*. Owing to the mountainous nature of the Moon's surface, and to the gradual shading off from light to dark, it does not appear as a sharply-defined semi-ellipse. In Plate I (a)

the terminator is the right-hand limb: the gradual transition from light to darkness is well shown. The points at *P* and *Q* are called the *cusps*. The line joining the cusps is perpendicular to the plane passing through the observer and the centres of the Sun and Moon. The angle between this plane and the observer's horizon is very variable, so that, for a given age of the Moon, the line joining the cusps will be inclined at different angles to the horizon in different months, at some times being nearly vertical and at others nearly horizontal.

Shortly after new Moon, the angular distance between the Sun and Moon as seen from the Earth is small, the Moon being slightly east of the Sun, owing to its more rapid easterly motion amongst the stars. When the age of the Moon is small, it therefore sets soon after sunset. During the first half of the lunar month, the Moon sets later each night, but always crosses the meridian between noon and midnight. The western limb is then the bright semicircular limb. At full Moon, the Moon is diametrically opposite to the Sun in the heavens and therefore crosses the meridian near midnight. After full Moon it crosses the meridian after midnight, but before the next noon and the eastern limb becomes the bright limb. It still continues to set later each night and to rise later until shortly before the next new Moon, the rising occurs only a little before the rising of the Sun.

44. To an observer on the Moon, the Earth would present phases which are the exact counterpart of the phases of the Moon as observed from the Earth. This will be evident from Fig. 28. Thus "new earth" will occur to the lunar observer at the time of "full moon" and "full earth" at the time of "new moon," while the first and last quarters of the Moon and Earth will occur together. The phenomenon of "Earthshine," or as it is popularly called "the old Moon in the arms of the new," is connected with the phenomenon of these complementary phases. When the Moon is very young and the slender bright crescent is visible, the remainder of the portion of the Moon facing the Earth is often seen faintly illuminated. This faint illumination is due to reflected sunshine from the Earth's surface falling on the Moon, it being then "full earth" to a lunar observer.

45. Orbit of the Moon.—The motion of the Moon relative to the Earth is much more complicated than that of the Sun and its detailed consideration would be far outside the range of this book. It will therefore only be possible to sketch the principal phenomena connected with it.

A first approximation to the motion can be derived, as in the case of the Sun, by measuring the apparent diameter of the Moon from day to day. The diameter will be found to vary in a manner which is approximately consistent with the hypothesis that the Moon moves around the Earth in an elliptical orbit, of which the Earth occupies one of the foci. When the Moon is at its least distance from the Earth it is said to be in *perigee*, and when at its greatest distance, it is said to be in *apogee*. The eccentricity of the orbit is much greater than that of the Earth's orbit, being 0.0549 or roughly $\frac{1}{20}$. This eccentricity is sufficiently large for the non-uniformity of the motion to be easily observable and it was a phenomenon well-known to the ancients. If we imagine a mean Moon to move in the Moon's orbit, starting with the true Moon at perigee and completing one revolution in the same time, then 7 days after passing perigee, the true Moon will be about $6^{\circ} 17'$ in front of the mean Moon; this difference will gradually decrease until apogee is reached by the two bodies at the same instant, after which the true Moon lags behind the mean Moon, the difference again reaching a maximum of about $6^{\circ} 17'$ at about 7 days before the next perigee passage. This inequality in the motion, arising from the eccentricity of the Moon's orbit, is called the *equation of the centre*. It is analogous to and may be compared with that component of the equation of time which is due to the eccentricity of the Earth's orbit (§ 29).

The plane of the Moon's orbit is inclined to the ecliptic at an angle of about $5^{\circ} 8' 43''$. The two points in which the orbit cuts the ecliptic are called the *nodes*, and that node at which the moon passes from the south to the north of the ecliptic is called the *ascending node*, the other node, at which the Moon passes to the south of the ecliptic, being called the *descending node*. The plane of the orbit is not fixed in space, a fact which has been known from very early times. This may be made evident in the following way: the position of the Moon at any instant can easily be fixed relatively to neighbouring bright

stars and the passage of the Moon across the ecliptic can therefore be determined, as the line of the ecliptic through the constellations is marked on any good star map. If the Moon crosses the ecliptic in the sign of, say, Gemini at a certain time, it will be found to be crossing it about 18 months later in the sign of Taurus, i.e. the node retrogrades through one sign, or about 30° in longitude, in a period of about 18 months. A complete revolution of the nodes in a retrograde direction relative to the fixed stars is completed in 6793.5 days, or approximately $18\frac{2}{3}$ years. The period of revolution relative to the First Point of Aries is somewhat greater, as the equinoxes themselves are also in retrograde motion, though at a much slower rate, and this motion has to be caught up. The Moon can therefore be regarded as moving in a plane which is meanwhile retrograding so as to complete one revolution around the ecliptic in about $18\frac{2}{3}$ years.

The inclination of this plane to the ecliptic is not absolutely constant, although its variation is slight. The inclination can be measured, after the position of the nodes has been found, by determining the Moon's latitude when it is 90° from the nodes, i.e. its maximum latitude. It is thus found that the inclination oscillates with a period of about 173 days and a total amplitude of about $18'$.

There is also a slight inequality in the rate of retrogression of the Moon's nodes; when the Sun is in the nodes or 90° from them, the rate of retrogression has its mean value, but when the Sun is 45° from a node, the rate has its maximum or minimum value, the greatest inequality between the mean movement of the nodes and the true movement being $\pm 1^\circ 40'$.

These inequalities in the inclination and the rate of retrogression were discovered by Tycho Brahé, who showed that they could be explained by supposing that the pole of the lunar orbit moves uniformly on a small circle of radius about $9'$ in a period of 173 days, whilst the centre of this circle moves in a small circle of radius $5^\circ 9'$, with its centre at the pole of the ecliptic, in a period of about $18\frac{2}{3}$ years.

46. In the preceding section, the movement of the plane of the Moon's orbit has been discussed and also the equation in the motion due to the eccentricity of the orbit itself. There are

other inequalities connected with the orbit of which mention must be made.

If the position of perigee be determined, by noting when the apparent diameter of the Moon is greatest, it will be found that the position of the perigee is not fixed relatively to the fixed stars, but has a direct motion of about $401''$ per day. Relatively to the fixed stars one revolution is completed in about 3,232 days, 11 hours, 14 minutes, or about 8 years, 311 days: relatively to the First Point of Aries a complete revolution occurs in the somewhat shorter period of 3,231 days, 8 hours, 35 minutes, as the equinox moves backwards and meets the perigee before the latter has completed a sidereal revolution.

Both the rate of motion of the perigee and the value of the eccentricity are variable, their variations being connected and having the same period, viz. half the time between two consecutive passages of the Sun through the perigee. The latter period is 412 days, so that the period of variation of the eccentricity is 206 days. The eccentricity is greatest when the Sun is in the line of apses of the lunar orbit (i.e. in the line joining perigee and apogee), and the motion of the perigee then has its mean value. The maximum inequality in the longitude of the perigee is $\pm 12^\circ 20'$, whilst the eccentricity varies between the limits 0.0549 ± 0.0117 .

47. **The Evection.**—It was stated in § 45 that the equation of the centre, or the maximum distance between the true Moon and a mean Moon moving in the orbit in the same period, amounts to $6^\circ 17'$, the equation being due to the eccentricity of the Moon's orbit. But owing to the variation of the eccentricity of the orbit, to which reference has been made in the preceding section, there will be a corresponding variation in the equation of the centre between the limits $5^\circ 3'$ and $7^\circ 31'$. It is customary to represent this variation by an inequality which is called the *Evection*, and the difference in distance between the true Moon and the mean Moon is then obtained by adding to the mean equation of the centre ($6^\circ 17'$) a variable term representing the evection. The value of the evection at any instant depends upon the distance of the Moon from perigee and also upon the distance between the Moon and the Sun, and it involves

not only the variation in the eccentricity to which reference has been made, but also the related variation in the longitude of the perigee. The combined effect can be represented by the expression $76' \sin (2E - \Theta)$, in which E represents the mean distance between the Sun and Moon at any instant, i.e. the elongation, and Θ is the angular distance from perigee of the mean Moon. The maximum value of the evection is therefore $1^\circ 16'$. The first three terms of the series for the distance of the true Moon from perigee are

$$\Theta + (6^\circ 17') \sin \Theta + (1^\circ 16') \sin (2E - \Theta),$$

the first term giving the position of the mean Moon, the second term the correction to its position on account of the equation of the centre and the third term the correction on account of the evection.

Before determining the period of the evection, reference may be made to two further lunar periods of revolution, additional to those mentioned in § 42.

The anomalistic period of revolution is the interval between two consecutive passages of the Moon through perigee. Owing to the forward movement of the perigee, this period is longer than the sidereal period and is equal to 27 d. 13 h. 18 m. 33 s. = 27.55455 days.

The Draconic period of revolution is the interval between two consecutive passages of the Moon through one of its nodes. Owing to the rapid retrograde motion of the node this period is the shortest of the various periods of revolution associated with the Moon and is equal to 27 d. 5 h. 5 m. 36 s. = 27.21222 days.

The period of the evection depends upon Θ , whose period is the anomalistic period (27.554 days) and upon E , whose period is the synodic period (29.531 days). The angular change of

$$(2E - \Theta) \text{ in unit time is therefore } 2\pi \left(\frac{2}{29.531} - \frac{1}{27.554} \right),$$

and this must equal $\frac{2\pi}{T}$, T being the period of the evection.

This period is therefore found to be 31.81 days.

It may be noticed that when the Moon is in perigee or apogee ($\Theta = 0$ or 180°), the evection vanishes if the Sun is either in

conjunction, opposition or quadrature ($E = 0^\circ, 90^\circ, 180^\circ, 270^\circ$).

48. **The Annual Equation.**—The Moon is held in its orbit around the Earth by the force of their mutual attraction. Both bodies are also attracted by the Sun and this attraction has to be taken into account in determining the motion of the Moon. Now if the Sun attracted both the Earth and the Moon with the same force acting in parallel directions, its attraction could obviously be disregarded in so far as the relative motion of the Moon and Earth is concerned. In effect it is only the difference of the attractions that requires to be considered. Now when the Sun and Moon are in conjunction, the intensity of the Sun's attraction at the distance of the Moon is greater than at the distance of the Earth, owing to the Moon being then nearer to the Sun than is the earth. The residual effect of the solar attraction on the Earth-Moon system at conjunction is therefore a force tending to draw the Moon away from the Earth. At opposition, on the other hand, the attraction is greater at the Earth's distance and is equivalent to a force tending to draw the Earth away from the Moon. As far as the Earth-Moon system alone is concerned, the forces in the two cases act in such a direction as to increase the distance apart of the two bodies. At quadrature, on the other hand, the intensities of the attraction at the Moon and Earth are equal although acting in slightly different directions. The resulting inequality in the motion of the Moon, termed the variation, is discussed in the next section.

The *annual equation* is a small inequality in the Moon's motion with a period of an anomalistic year which is due to the variation of the Earth's distance from the Sun. At perihelion, when the Earth-Moon system is nearest to the Sun, the residual effect of the solar attraction just discussed is greater than at aphelion when the system is at its greatest distance from the Sun. At perihelion, therefore, there is in the mean a greater force arising from the Sun's attraction tending to draw the Earth and Moon apart than there is at aphelion: the effect is obviously the same as would be produced if the Earth's attraction on the Moon was somewhat less at perihelion than at aphelion. The result is that for the six months of the

year around perihelion (October 1 to April 1), the mean radius of the lunar orbit is greater and the Moon's angular velocity in its orbit is less than their annual mean values, whilst for the six months around aphelion (April 1 to October 1), the mean radius is less and the angular velocity greater than the average. On account of this inequality, a correction is necessary to the mean longitude of the Moon to obtain the true longitude, the correction having its largest negative value on April 1, and its largest positive value on October 1, and vanishing at perihelion and at aphelion. It can be stated in the form

$$\text{True longitude} = \text{mean longitude} - (11' 16'') \sin \theta,$$

where θ is the Sun's longitude measured from perihelion, which is 0° on January 1 and increases at the rate of about 1° per day, being 180° on July 1.

49. **The Variation.**—In addition to the equation of the centre, the evection and the annual equation, there is a fourth

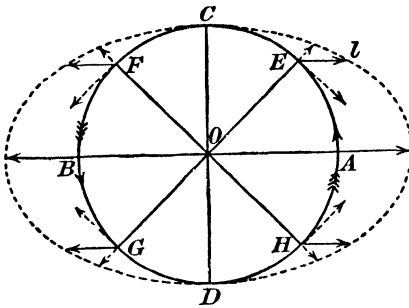

FIG. 31.—The Lunar Variation.

principal inequality in the motion of the Moon. This is called the variation, and as explained in the preceding section, it is due to the variation in the magnitude of the residual solar attraction on the Earth-Moon system during a synodic month. Referring to Fig. 31, if O represents the position of the Earth, $ACBD$ the

orbit of the Moon described in the direction of the arrow, A, B the positions of the Moon when in conjunction and opposition respectively, C, D the positions of quadrature, then at any other point E of the orbit, the effect of the residual solar attraction can be represented by the arrow El . This is greatest at A and B . El can be resolved into two components, Em normal to the orbit and En tangential to the orbit. We shall neglect the normal force. The tangential component obviously vanishes at A and B , also at C and D . Between D and A , and again between C and B , it acts in such a way as to accelerate the motion, whilst between A and C, B and D it acts

so as to retard the motion. The variation in velocity produced in this way reaches its greatest value at A and B and its least value at C and D , and if OE, OF, OG, OH make with AB and CD angles of 45° , it is apparent that the velocity will be greater than its mean value between H and E, F and G and less than the mean value between E and F, G and H . The inequality in motion so produced has therefore a period of half the synodic month, or 14.77 days, and its magnitude has been found to be $39' \sin 2E$, E being the angle subtended at the Earth by the directions to the Moon and Sun. Thus we have

$$\text{True longitude} = \text{mean longitude} + 39' \sin 2E.$$

50. Tables of the Moon's Motion.—The preceding discussion of the four principal inequalities in the Moon's motion will give a small indication of the complexity of the motion of the Moon. The problem of determining the motion of the Moon is a particular case of the celebrated *problem of three bodies*, which may be stated in the following form: Three bodies of masses m_1, m_2, m_3 which severally attract each other with forces proportional to the products of their masses and inversely proportional to the squares of their distances apart, are set in motion from certain points, with given velocities in given directions; to determine the subsequent motion. The problem is not capable of a general solution, but in certain cases an approximate solution can be obtained whose accuracy will depend upon the degree to which the approximation is carried and this, in general, is conditioned by the labour involved. In the case of the system Earth-Moon-Sun the great distance of the Sun simplifies the problem to some extent, but this is largely offset by the greater mass of the sun. The perturbing effects of the major planets have also to be taken into account. The solution of the problem is required in order to predict, with the accuracy required, the position of the Moon for some years ahead.

Newton, in his immortal *Principia*, published in 1686, was the first to attempt to explain on dynamical principles the motion of the Moon, but the first tables of the Moon's motion, constructed so as to enable the position to be readily obtained at any required time, were given by Clairaut in 1752. The problem continued to attract the attention of the foremost

mathematicians until Hansen succeeded in developing the theory in a form adaptable to numerical computation. As the outcome of many years' work, his *Tables de la Lune* were published in 1857 by the Admiralty and have served until the present time as the basis for the computation of the Moon's positions, which are given in the *Nautical Almanac*. The observed position of the Moon has, however, gradually deviated from the position computed from the tables. In the French *Connaissance des Temps*, the places of the Moon are computed from tables published in 1911 by Radau and based on Delaunay's Theory. This theory is the most general theory of the motion of the Moon yet given, but, unfortunately, it is not very well adapted to numerical computation. In 1920 a new set of tables, prepared by E. W. Brown from his own lunar theory, were published. They are the most complete tables ever computed, and are the outcome of thirty years' work. The theory includes 1,500 separate terms, of which the equation of the centre, evection, etc., are the principal, and the tables enable the position to be obtained without the enormous labour of computing each time these 1,500 terms. Brown's tables will in future be used in the computations for the *Nautical Almanac*, commencing with the year 1923.

51. The Secular Acceleration of the Moon.—There is one term in the motion of the Moon to which reference must be made, as its origin is to some extent obscure. If a represents the Moon's mean motion in longitude in unit time, then—apart from the various periodic terms, the longitude of the Moon at time t can be represented in the form

$$L = L_0 + at,$$

L_0 being the longitude at the time chosen for origin.

It is found, however, that an equation of this type cannot be made to satisfy both modern observations of position and ancient observations of times of eclipses. For long intervals of time a formula of the type

$$L = L_0 + at + bt^2$$

is found to be necessary. If the unit of time is taken as a century of 36,525 days, b has the value of approximately $10''$ or $11''$ and this quantity is generally called the lunar secular

acceleration. It is, in part, due to purely gravitational causes : it was shown by Adams that the slow diminution of the eccentricity of the Earth's orbit will produce an apparent secular acceleration of the Moon's motion of amount $6''\cdot 1$. The difference between this quantity and the observed amount is not due to gravitational causes. It is now generally attributed to a very minute and gradual lengthening of the period of the Earth's rotation, which serves as our basis of time determination. The only means available for testing the assumption that the period of rotation of the Earth is invariable is by observations of the members of the solar system and the comparison of the results with gravitational theory. But the change is actually so minute that observations extending over a long period are necessary. The change in the period of rotation is generally attributed to dissipation of energy by friction between tidal currents and the sea bottom and recent investigations show that the probable dissipation so produced is of the right order of magnitude to account for the residual lunar acceleration.

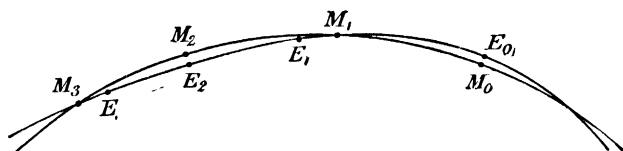

FIG. 32.—The Path of the Moon around the Sun.

52. **Path of the Moon with respect to the Sun.**—We have hitherto been considering the orbit of the Moon with respect to the Earth ; but the Moon along with the Earth moves around the Sun and it is of interest to inquire what is the actual path of the Moon relative to the Sun. Since the Moon goes round the Earth about $12\frac{1}{2}$ times in one year, the Moon's path would cross that of the Earth about 25 times, if the two paths were in the same plane. It might therefore be anticipated that the path of the Moon relative to the Sun would consist of a series of waves or even loops. Actually, however, the path is everywhere concave to the Sun, a fact of the truth of which it is not at once easy to satisfy oneself. It is obvious that at full Moon, when the Moon is on the side of the Earth remote

from the Sun, its path will be concave to the Sun, but it might have been anticipated that at new Moon its path would be convex. Actually the paths of the Earth and Moon are somewhat as shown in Fig. 32. E, M denote the positions of the Earth and Moon at corresponding instants, the suffixes $0, 1, 2, 3$ denoting new Moon, first quarter, full Moon and last quarter respectively. It will be seen that the path of the Moon is a sort of distorted oval, everywhere concave to the Sun.

That the path of the Moon at new moon is concave to the Sun can be shown from elementary considerations. In

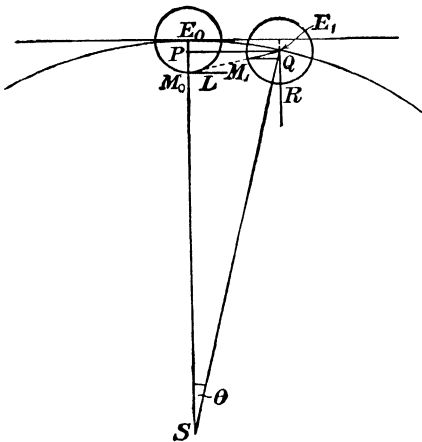

FIG. 33.—To illustrate the Concavity of the Moon's Path.

Fig. 33, S is the Sun, E_0, M_0 the positions of the Earth and Moon respectively at the time of new moon. A short time later suppose the Earth to have moved to E_1 , and the Moon to M_1 . It will be sufficiently accurate for the present purpose to suppose both orbits to be circular and in the same plane, in which case $E_0S = E_1S = R$, the radius of the Earth's orbit round the Sun, and $E_0M_0 = E_1M_1 = r$, the radius of the

Moon's orbit round the Earth. If M_0L is the tangent to the Moon's orbit at M_0 , then the orbit relative to the Sun will be concave if M_1 is on the same side of M_0L as is the Sun.

Calling the angle E_0SE_1, θ , and R being the point in which the line through E_1 parallel to E_0S cuts the orbit of the Moon relative to the Earth when the Earth is at E_1 , it is seen from the figure that if the line EM always pointed in a fixed direction, so that the Moon did not revolve relative to the fixed stars, the Moon would be at R when the Earth was at E_1 and the motion of the Earth would have carried it a distance equal to E_0P (the projection on E_0M_0 of E_0E_1) below M_0L , i.e. an amount $R(1 - \cos \theta)$. Actually the Moon moves from R to M_1 , and since its average daily angular motion relative to the

stars is about 13° , the angle M_1E_1R will be 13θ . The Moon is thereby lifted a distance $r(1 - \cos 13\theta)$ in a direction perpendicular to M_0L above R , and the resultant distance of M_1 below M_0L will be $R(1 - \cos \theta) - r(1 - \cos 13\theta)$.

If θ is a small angle, we can put $1 - \cos \theta = \frac{\theta^2}{2}$, and since

$R = 93,000,000$ miles $r = 240,000$ miles, $R = 390r$ approximately. The above expression is therefore

$$\frac{\theta^2}{2} \left\{ 390r - (13)^2r \right\} = 110r \theta^2$$

and is therefore positive. Therefore, after new moon, the Moon moves below M_0L , i.e. towards the Sun, and its orbit is therefore concave to the Sun.

53. The Rotation of the Moon.—Does the Moon rotate on its axis as well as travel round the Earth? This is a question which is easily answered, although the answer is sometimes found puzzling. Observation of the Moon with a low telescopic power, such as a pair of prismatic binoculars, will suffice to show the principal surface details. Continued observations will reveal that these markings are permanent, and that the Moon always turns the same face towards the Earth. This means that the Moon rotates on its axis in the same time that it takes to make an orbital revolution about the Earth. That this is so will be readily seen from Fig. 34. E denotes the position of the Earth, M_0 the centre of the Moon at any instant and A the point on the Moon's surface in the line EM_0 . At any subsequent instant suppose the centre of the Moon to have moved to M_1 and let B be a point on its surface such that M_1B is parallel to M_0A , and C another point such that M_1CE is a straight line.

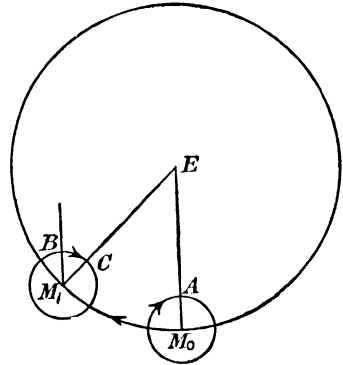

FIG. 34.—Rotation of Moon on its Axis.

If the Moon did not rotate on its axis, the point A would

have moved to B when M_0 moved to M_1 . Observation shows, however, that A moves to C . Therefore, whilst the Moon has moved relatively to the Earth through an angle M_0EM_1 , it has turned on its axis through an angle BM_1C . But since M_1B and M_0A are parallel, these angles are equal, so that the two rates of rotation are identical.

54. The Librations.—The statement that the Moon always presents the same face to the Earth is only approximately correct, for sometimes a little more of one portion of the surface and a little less of the diametrically opposite portion is seen. This phenomenon is called *Libration* and is due to a variety of causes. There are three principal librations to which reference may be made.

The Libration in Longitude.—This libration is due to the rotation of the Moon on its axis being at a uniform rate whilst

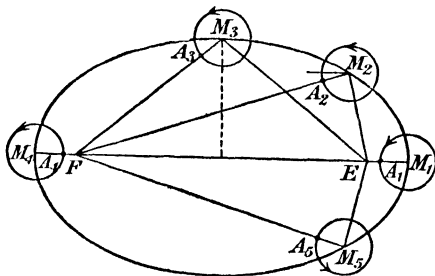

FIG. 35.—The Moon's Libration in Longitude.

its orbital revolution around the Earth takes place, owing to the eccentricity of its orbit, at a rate which is not uniform. The result is that sometimes a little more of the eastern limb and sometimes a little more of the western limb may be seen. This libration can be discussed and its approximate magni-

tude very simply calculated owing to a remarkable theorem in dynamics, viz. : that if a body is moving in an elliptic orbit under the gravitational attraction of another body which is in one of the foci, then the line joining the body to the other focus will rotate at a constant rate which is equal to the *mean* rate of rotation of the body about the former focus, provided that the eccentricity of the orbit is small. The theorem is an approximation, which is justifiable if the square of the eccentricity can be neglected.

Referring to Fig. 35, E represents the Earth in one focus of the Moon's orbit, F the other focus, $M_1, M_2, M_3 \dots$

successive positions of the Moon's centre. Let A_1 be the point on the Moon's surface which is in the line FE produced. Then when the centre of the Moon is at M_2 , A_1 will have moved to A_2 , on the line M_2F , because the rate of rotation of the line FM and the rate of rotation of the Moon on its axis are equal, both being equal to the mean rate of rotation of the Moon about the Earth. Therefore, the point on the Moon's surface which previously pointed to E now points to F , and when the Moon is at M_2 more of the surface on one side has come into view, the amount being measured by the angle FM_2E . More of this side will remain in view until the Moon has come to the position M_4 on EF produced; thereafter, for the second half of its revolution, more of the surface at the other limb will come into view, as at M_5 . The libration will be a maximum when the Moon is at the end of the minor axis of its orbit, as at M_3 , and then $FM_3 = EM_3 = a$, the semi-major axis of the orbit, since the sum of the radii to the two foci always equals $2a$. But the distance between the foci of an ellipse is $2ae$, so that since the distance EF is really very small compared with EM_3 , it follows that the angle $EM_3F = EF/EM_3 = 2e$. Since the eccentricity of the orbit is 0.0549, this gives $6^\circ 15'$ as the maximum libration in longitude. On account of the inequalities in the Moon's motion, the actual value of the libration is found to be somewhat larger than this value.

The Libration in Latitude.—This libration is due to the axis of rotation of the

Moon being inclined from perpendicularity to the plane of its orbit by about $6\frac{1}{2}^\circ$. The lunar equator is there-

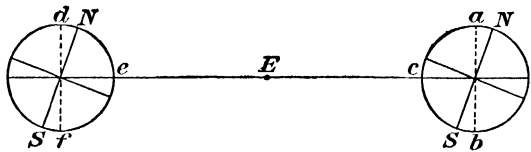

FIG. 36.—The Moon's Libration in Latitude.

fore inclined to the orbital plane at the same angle. The axis of rotation remains constantly parallel to the same direction in space throughout the entire orbital revolution, just as does the Earth's axis. From Fig. 36 it will be seen that the result of this is that now more of the region about the Moon's south pole will be seen and now more of the region about its

north pole, the portions visible in the two positions shown being the hemispheres *acb*, *def*.

The Diurnal Libration.—The statement that the Moon presents the same face always to the Earth holds (in the absence of librations) for the centre of the Earth. But obviously, if there are two observers at different points of the Earth's surface, each will see a small portion of the Moon's surface which will be invisible to the other. If, instead of two observers, we consider one observer whose position changes on account of the Earth's rotation, it follows that as he is moved round he will gradually see slightly different portions of the surface. This libration effect is called diurnal or parallactic libration. Its amplitude can amount nearly to 1° .

55. The Distance of the Moon.—The principle of the method of determining the distance of the Moon is very simple.

It consists in making simultaneous observations of the position of the Moon relative to the stars at two observatories widely separated on the Earth, such as Greenwich and the Cape of Good Hope, and using the known distance between these observations as a base-line. In order to make the theory as simple as possible we will suppose the two observatories to be on the

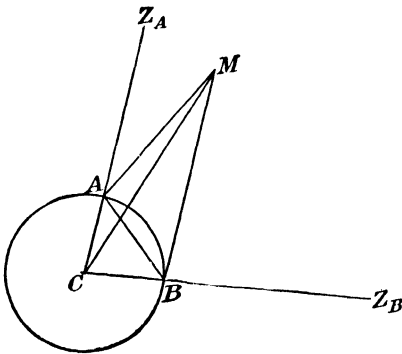

FIG. 37.—Determination of the Moon's Distance.

same meridian of longitude, at *A* and *B* in Fig. 37. *C* is the centre of the Earth and *M* the position of the Moon at the instant of crossing the meridian. The latitudes of *A* and *B* being known, the distance *AB* and the angles of the triangle *ABC* can be calculated. Astronomical observations give the angles *MAZ_A* and *MBZ_B*, which are the zenith-distances of the Moon at *A* and *B* respectively at the instant of meridian transit. The angles *MAB* and *MBA* are then determined, since, for instance, $MAB = 180^\circ - MAZ_A - BAC$

and both the latter angles are known. In the triangle MAB , the base AB and the two adjacent angles are now known and therefore the distances MA , MB can be calculated. The distance, MC , from the centre of the Earth can then be derived from either the triangle MAC or the triangle MBC . The mean distance of the Moon is about 240,000 miles or about thirty times the Earth's diameter. On account of the eccentricity of the orbit, the distance can vary between the limits 222,000 and 253,000 miles.

The position of the Moon given in the *Nautical Almanac* is referred to an observer supposed to be situated at the centre of the Earth. To determine the apparent position for an observer at any point of the Earth's surface a correction must be applied for what is called the Moon's "parallax." The *horizontal parallax* of the Moon is the angular semi-diameter of the Earth as seen from the Moon, i.e. r/R , r being the radius of the Earth and R the distance from the centre of the Earth to the Moon. If A is a point on the Earth's surface, C the Earth's centre, and M the Moon (Fig. 38), then to reduce the zenith-distance of the Moon as observed at A to its value for the centre of the Earth, the angle AMC must be subtracted. But angle $AMC = r \sin Z / R$ or $\tilde{\omega} = \tilde{\omega}_0 \sin Z$, where $\tilde{\omega}_0$ is the horizontal parallax, or the value of $\tilde{\omega}$ when $Z = 90^\circ$, i.e. the correction for parallax is proportional to the sine of the zenith-distance. The constant of proportionality is the "horizontal parallax," and its value can be calculated when the distance of the Moon has been determined. The horizontal parallax of the Moon can vary between the limits $53'.9$ and $61'.5$.

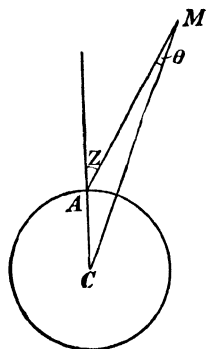

FIG. 38.—The Parallax of the Moon.

56. The Size of the Moon.—To determine the size of the Moon it is only necessary to know its angular diameter and its distance. The former quantity can be measured directly, and the method of determining the latter has just been explained. In this way it is found that the diameter of the

Moon is about 2,200 miles or rather more than one-quarter of that of the Earth. The volume of the Earth is about fifty times that of the Moon. If the average density of the Moon were the same as that of the Earth, this would also give the ratio of their masses, but, as we shall now show, the actual ratio is somewhat greater than this figure.

57. The Mass of the Moon.—The method of determining the mass of the Moon involves an interesting application of the law of gravitation. We have heretofore supposed the

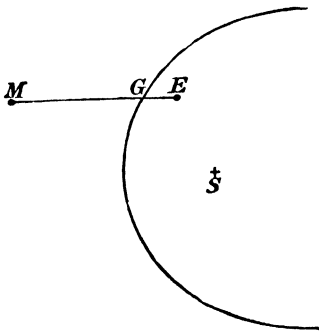

FIG. 39.—Determination of the Mass of the Moon.

Earth to move around the Sun in an elliptic orbit: this is not strictly accurate. The Earth and Moon form a compound system, in motion around the Sun, and the law of gravitation requires that their centre of gravity should describe the elliptic orbit, so that the orbit of the Earth will not be strictly elliptical. If E , M represent the masses of the Earth and Moon respectively (Fig. 39), then the centre of gravity of the compound system

is in the line joining their centres and at a distance $\frac{M}{M + E} R$ from the centre of the Earth. Whilst the centre of gravity describes its elliptic orbit, the Earth moves around it in an approximately circular orbit of radius $MR/(M + E)$; the Moon describes a similar orbit of larger radius $ER/(M + E)$, the line joining the two bodies always passing through their centre of gravity. The period of this motion with respect to the Sun is a lunar month. Its effect is to produce an apparent displacement of the Sun as viewed from the Earth, the Sun's apparent motion being slightly accelerated during one half of the lunar month and slightly retarded during the other half. The total change in the apparent place of the Sun is small, amounting only to about $12''$. The distance of the Sun from the Earth is known in other ways to be about 93,000,000 miles and at this distance $12''$ in angular measure corresponds to

about 5,760 miles. That is, the radius of the orbit of the Earth about the centre of gravity of Earth and Moon is 2,880 miles, and this must be equal to $M/M + E$ times the Moon's distance. The latter's distance having previously been determined, it is deduced that the mass of the Moon is about $1/81$ of that of the Earth. The mean density of the Moon must therefore be less than that of the Earth, for equal densities would have given a ratio of $1/50$. The ratio of the densities is about $1.6 : 1$.

58. Rising and Setting of the Moon.—The phenomena connected with the rising and setting of the Moon are more complicated than in the case of the Sun on account of the large diurnal variations in declination to which the Moon is liable. These are due to the rapid daily motion in its orbit of about $13^\circ 11'$; when the Moon is near the intersection of its orbit with the equator, the diurnal change in declination is given by $\sin 13^\circ 11' \sin i = 0.228 \sin i$, where i is the inclination between the plane of the Moon's orbit and the equator. Since the ecliptic is inclined to the equator at an angle of $23^\circ 27'$ and the lunar orbit is inclined to the ecliptic at $5^\circ 9'$, the inclination of the lunar orbit to the equator has the limits $23^\circ 27' \pm 5^\circ 9'$ or $18^\circ 18'$ and $28^\circ 36'$, corresponding to diurnal motions in declination of $4^\circ 6'$ and $6^\circ 16'$ respectively. These values are for a mean angular motion of the Moon: when the lunar perigee is in the equator, which occurs twice in nine years, the daily motion is greater than the mean and the daily variation in declination can then exceed 7° . On the other hand, when the Moon is at a distance of 90° from its point of crossing the equator, the declination changes very slowly, the motion of the Moon being at such times nearly parallel to the equator.

The effect of the changes in declination on the times of rising and setting have now to be considered. We will neglect at first the Moon's motion in right ascension; an increase in declination without any alteration in right ascension would lift the Moon nearer the north pole, along a great circle; the length of time it would stay above the horizon would then be increased at places in the northern hemisphere, but the time of crossing the meridian would be unaltered, as this

depends solely upon the right ascension. It follows that an increase in declination will cause the time of rising to become earlier and the time of setting to become later ; the reverse results will follow from a decrease. If, on the other hand, the right ascension increases without any change of declination, the times of rising, of crossing the meridian and of setting will all be retarded equally.

Combining the two effects, there is a normal retardation from day to day in the times of rising and setting due to the progressive increase in the right ascension of the Moon ; this is increased or decreased by the changes in declination. When the Moon crosses the First Point of Aries, the declination is increasing most rapidly and this tends, therefore, to counteract to some extent the normal retardation in the time of rising ; the time of setting, on the other hand, is retarded on both accounts, so that the normal retardation in the time of setting is increased. Similarly, when the Moon passes through the autumnal equinox, the declination is decreasing most rapidly and the retardation in the time of rising is then greater than usual, and in the time of setting is less than usual.

The Moon passes through the equinoxes once in each revolution, so that the phenomena of a small and of a large daily retardation in the time of rising and setting must occur once every month. The mean retardations of about 52 minutes must therefore show considerable variations throughout the month. The phenomenon is most noticeable at the autumnal equinox, for the Moon when in the First Point of Aries will then be in opposition to the Sun and will therefore be full, so that the rising will take place near sunset. For several nights in succession, therefore, near full moon the Moon will rise approximately the same time. This is the phenomenon known as the Harvest Moon. In southern latitudes the same phenomenon will occur at the vernal equinox.

The times of moonrise or set are given in ordinary almanacs such as Whitaker's ; an examination of these times will illustrate the phenomena described above. One point in reference to these figures deserves mention : the almanacs give only the times of moonrise or moonset, never both as in the case of the Sun. This is because either the rising or

the setting occurs during daylight and is not observable. Occasionally, there will be a day for which neither the time of rising nor the time of setting will be given. If, for instance, the Moon rises just before the beginning of a certain solar day, it may not rise again until just after the end of the same day, the lunar day being longer than 24 hours.

One other feature in connection with the path of the Moon in the heavens may be mentioned. The full moon always appears at the point in the heavens which is opposite to the Sun. It follows that near the time of winter solstice the full moon must be near the summer solstice point of the ecliptic and gets much closer to the zenith than it does near the time of summer solstice, when full moon occurs at the winter solstice point. For this reason, the Moon is said to "ride high" in the winter.

59. The Tides.—It is mainly to the attraction exerted by the Moon on the waters of the oceans that the tides are due. The Moon, therefore, is of enormous economic importance to mankind.

To explain the production of the tides we shall, for the sake of simplicity, suppose the Earth to be a sphere uniformly covered with a relatively shallow ocean. The Moon exerts an attraction on the Earth and on the waters, as a result of which we should expect the water to be heaped up at the point of the Earth directly under the Moon, the attraction of the Moon on the water being greater than its attraction on the land; and also at the diametrically opposite point, because the attraction of the Moon on the land will there be greater than on the water and will therefore pull the Earth away from the water.

Actually, the phenomena are somewhat more complicated, the actual heaping up of the water which constitutes the tides being due to causes of a less simple nature. Consider the attractive force on a small volume of water, not directly under the Moon. The force will act in the direction towards the Moon and can be resolved into two components, one normal to the surface and one tangential to it. It is the latter which is the more important, as it causes the particles of water to flow over the Earth's surface, towards the point where the

Moon is overhead. When the Moon is east of a given place the water particles will be pulled towards the east; when it is west of the same place, they will be pulled towards the west. There is therefore an oscillation of the water particles in a period of half a lunar day. The tangential forces are therefore responsible for a heaping up of the water at the point of the Earth nearest the Moon, the particles on all sides being pulled towards this point. The crest of the tidal wave so produced follows the Moon round as the Earth and Moon rotate. Actually there is a lag in the effect, so that the crest is not directly under the Moon and a further complication is introduced by the irregular contour of the ocean boundaries. Approximately, the crest is at about 90° distant from the point under the Moon, and there is a second crest diametrically opposite to it, causing two high and two low tides per day.

These two tides are, in general, of unequal height. This is due to the fact that the Moon does not move in the plane

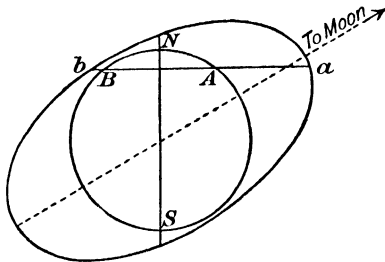

FIG. 40.—The Diurnal Inequality in the Tides.

of the Earth's equator: the attraction of the Moon on the water covering our simple model will pull the spherical boundary of the water into the shape of a spheroid, but the axis of the Earth will not be the axis of the spheroid. This will be made clear by Fig. 40, in which the heaping up of the water is much exaggerated. The

high tide at any point A may be represented by the line Aa ; it will also be high tide at the same instant at the point B , the height there being represented by the line Bb , which is obviously smaller than at A , with the Moon, as shown, north of the equator. But after 12 hours, A will have come to B , owing to the rotation of the Earth, and the height of the next high tide at A is therefore represented by Bb . The two tides will only be equal when the Moon is on the equator and this occurs twice per month. The phenomenon is known as the diurnal inequality of the tides.

There are two other causes which operate to produce inequalities in successive high tides. The first is the solar attraction which operates in an exactly similar manner to that of the Moon. Although the Sun is much larger than the Moon, its greater attracting power on this account is more than counterbalanced by its much greater distance, so that the solar tide is only about 5/11th of that produced by the Moon. At full and new moon, however, the tidal force due to the Sun is added to that due to the Moon, whereas, at quadratures, the forces are in opposition. The high tides at new and full moon are called *spring tides*, and are therefore much higher than those at first and third quarters, which are called *neap tides*. The ratio in the heights is $11 + 5$ to $11 - 5$ or 8 to 3. The second cause of the inequalities in the high tides is the large eccentricity of the lunar orbit, the resulting variation in the Moon's distance causing the tide-raising force to be about $\frac{1}{5}$ greater at perigee than at apogee. When perigee occurs at the time of new or full moon, the high tides will be particularly high and the low tides correspondingly low.

For an exact tidal theory, the actual contours of land and sea need to be taken into account. The preceding very simple theory will serve to illustrate the manner in which the tides are produced and the general qualitative effects which result.

60. Surface Structure on the Moon.—The more important features on the surface of the Moon can be revealed by a small telescope of, say, three or four inches' aperture with eye-pieces giving magnifications up to about 200 diameters. For the minor details larger instruments are necessary, but the magnification cannot, in general, be increased beyond about 1,000 diameters with any advantage on account of atmospheric irregularities. With this magnification, the Moon is in effect brought to a distance of about 240 miles from the Earth and objects only 500 ft. in diameter can be seen.

A small telescope is sufficient to reveal the rugged nature of the lunar surface; the details can be most easily seen several days before or after full Moon, as the Sun's light then falls on the surface obliquely, throwing shadows, which indicate the relief. Near full Moon, the Sun's light falls nearly

in the direction of our vision and then no shadows can be seen from the earth.

On the only side of the Moon which we can see, there are ten mountain ranges, besides numerous isolated lofty peaks, more than 1,000 cracks or rills and at least 30,000 craters : most of these objects have been given names. There are also several large areas, almost devoid of craters, which appear darker than the rest of the surface : from long established usage, dating back to the time of Galileo, these areas have been called *maria* or seas, although it has long been known that they are not seas. The system of lunar nomenclature and many of the names of the principal objects date back to the seventeenth century : the first map of the Moon was, in fact, constructed by Hevelius in 1645. These dark areas are well shown in Plate I (*a*). The contrast in brightness between the dark and bright areas is increased in a photograph, owing to the light from the dark areas being actinically weaker than that from the bright. In Plate 2, showing a portion of the Moon photographed with the 100-inch reflector of the Mount Wilson Observatory, one of the dark areas, the Mare Imbrium, can be seen in the centre of the plate.

The most numerous objects to be seen are the so-called craters which are to be found all over the visible surface. Plate III gives an indication of the large number of craters on the Moon's surface. They vary greatly in size, from the great walled-plains such as Archimedes, which appear as circular mountain ranges surrounding more or less level plains, and which may be more than 100 miles in diameter, to minute craters which require the highest telescopic power available to render them visible. Many of the craters, e.g. Copernicus, have a lofty mountain peak as their centre. Copernicus is shown in Plate I (*b*), in which the central peak is easily distinguished. The outer walls and also the central peaks may reach enormous heights, some exceeding 15,000 ft. These heights can be calculated from a measurement of the angular length of the shadow cast, combined with a knowledge of the angle at which the Sun's light is falling on the surface and of the distance of the Moon. From some of the craters, under favourable conditions of illumination, bright rays or streaks can be seen radiating radially in all directions, sometimes

extending to very great distances and passing over many craters in their course. Such streaks can be well seen, for instance, in Plate I (*a*) radiating from the large crater, Tycho, towards the top of the photograph, and in the case of Copernicus, the large crater in the right-hand top corner of Plate II. The nature of these streaks is not known.

The origin of these craters has been the subject of much discussion and is by no means settled. The term "crater" suggests a volcanic origin and is, on that account, perhaps as unfortunate and misleading as is the description of the dark areas as seas. One theory of their formation does, however, attribute them to volcanic origin. It is supposed that many ages ago matter was ejected from the central mountain and that this matter gradually piled up and formed the outer ring. Although the theory has gained wide acceptance, it is not without serious difficulties. Owing to the force of gravity on the Moon being only about one-sixth of that on the Earth, a given eruptive force would produce a much greater effect on the Moon than on the Earth. But it is difficult to believe that some of the enormous lunar craters could have been produced by volcanic forces similar to those which have produced most of the craters on the Earth. Moreover, there are no volcanic formations on the Earth which resemble at all closely the lunar craters. Signs of lava flow on the Moon which might have been anticipated from the violence of the supposed disturbance, are almost or entirely lacking.

The only serious rival theory supposes that the craters were produced by the bombardment of the lunar surface by numerous meteors. Thus, whilst the volcanic theory attributes their origin to the action of internal forces, the meteoric theory attributes it to the action of forces from outside. The objections to this theory are even more serious than in the case of the volcanic theory. Meteors which could have produced the larger craters must have been of enormous size and it is impossible to believe that the Moon could have been so bombarded without many of the meteors having also struck the Earth. Signs of meteoric bombardment might therefore reasonably be expected to be found on the Earth. There is, indeed, a crater in Arizona which is supposed to have been formed as the result of a large meteor striking the Earth :

it is very similar in structure to many of the lunar craters, although its size is insignificant in comparison, its diameter being only about three-quarters of a mile, and the height of the walls above the surrounding plain only about 150 ft. The craters produced by bombs dropped from aeroplanes are also generally similar to the lunar craters, and this fact has been advanced in support of the meteoric hypothesis. It might be argued that the later processes of sedimentation on the Earth would have concealed craters similar to those on the Moon, but it does not seem probable that all traces would have disappeared and no evidence be found in rock strata. No such evidence has been discovered by geologists. A further very strong objection to the meteoric theory is that, to form craters in this way, the meteors must all have fallen vertically. But if a stream of meteors coming from outside had struck the Moon, many of the impacts must have been oblique and many merely glancing impacts. The formations which might have been so produced are conspicuously absent. There is, indeed, a long straight valley in the range of lunar mountains called the Alps, but this appears to be an exceptional formation.

The cause of the origin of the craters must therefore be regarded as still an open question: no theory yet advanced can account satisfactorily for their existence on the Moon and not on the Earth. Equally puzzling are the systems of bright streaks radiating from Tycho and a few other craters. These cast no shadows and are therefore neither elevations nor depressions. They pass on in straight lines over craters, rills, or whatever object lies in their track. No satisfactory explanation of them has yet been given.

The mountain ranges on the Moon are extremely rugged and very lofty, but in view of the smallness of the force of gravity at the surface of the Moon, there is no difficulty in supposing them to have been produced by forces similar to the forces which have given rise to the mountains on the Earth. In the upper half of Plate II can be seen the Apennines, the finest range of mountains on the Moon.

61. Physical Conditions on the Moon.—As far as is known with certainty, the Moon is a dead world which shows

no evidence of change. There is little doubt but that it has no atmosphere. When the Moon in its motion eastward amongst the stars overtakes a star, the disappearance or "occultation" of the star as the Moon passes in front of it takes place with remarkable suddenness. If the Moon possessed an atmosphere, the rays of light from the star passing through the atmosphere would be bent or refracted, and the nearer the rays approached the limb of the Moon, the longer would be their path through this atmosphere and the greater the amount of their bending. The star would therefore disappear gradually. There are other arguments which support this conclusion: the limb of the Moon, projected upon the Sun's disc during a solar eclipse, is perfectly sharp, and the outlines of the shadows of the lunar formations are very sharp, with no gradation at the boundary between light and dark. The theory of gases leads to the same conclusion; a gas consists of a large number of molecules which are in motion to and fro with very large velocities: at the confines of the Earth's atmosphere there are molecules continually flung outwards with velocities of such magnitude that the force of the Earth's gravitation cannot hold them back and they escape into space. This process on the Moon would be much more rapid owing to the reduced gravitation, and it is probable that, if the Moon ever had an atmosphere, the mass of the Moon was too small to enable it to be retained.

It is probable also that there is no water on the Moon. There is little or no appearance of erosion or weathering on the lunar mountains or craters, and there are certainly no clouds to be seen at any time. In the absence of an atmosphere and of water, the existence of any vegetation is very improbable, although competent observers have occasionally seen patches of a greenish hue which have been thought to show signs of change during the course of the lunar month, and have been conjecturally interpreted as vegetation. The inference seems at present hardly justifiable. Any evidence of change on the Moon's surface must be accepted with caution as, owing to the variable angle under which the sunlight falls and the change in the length and position of the shadows, apparent changes in the appearance of the craters and peaks may easily be misinterpreted as actual physical

changes. At present, the existence of any physical change on the Moon has not been established to the general satisfaction of astronomers, though the possibility of slight changes should not be excluded.

62. The Origin of the Moon.—According to the theory proposed by G. H. Darwin and now generally accepted, the Moon and the Earth were formerly one body which had probably been thrown off from the central body of the solar system. The entire mass had then a high temperature, and was in a fluid or plastic condition and in rapid rotation about an axis. Such a mass would gradually cool, contracting meanwhile with a corresponding increase in its rate of rotation. The course of evolution of the mass can be traced out by mathematical reasoning, and Darwin showed that the configuration would at first be that of an ellipsoid, rotating about its short axis. This would, in the course of time, give place to a pear-shaped figure, and then to a dumb-bell shape, the neck of which would gradually contract, until eventually the mass would split into two unequal masses almost in contact and in rapid rotation about their centre of gravity. On account of their plastic nature, each body would raise on the other large tides. It can be shown that tidal protuberances thus produced will act in such a manner as to accelerate the motion of the bodies in their orbits; it follows from mechanical principles that this acceleration of the motion will result in an increase of the orbital radii and in the periods of revolution. The Moon and the Earth, which were in close contact and rapid rotation originally, therefore gradually separated and there was a corresponding increase in the lunar period. As the plasticity of the bodies decreased and their separation increased, the effect of the tidal forces gradually diminished and finally the two bodies reached their present condition. It can further be shown that the effect of tidal action would be to slow down the period of rotation of each body on its axis until this period became equal to the period of rotation of the bodies the one about the other. In the case of the Moon, as we have already seen, this process is completed. It is known that the period of rotation of the Earth on its axis is increasing, though very slowly. According to Darwin's theory this process should

continue and, if the theory is correct, the last stage of equilibrium of the Earth-Moon system will be one in which the terrestrial day and the lunar sidereal day will each be equal to the period of revolution of the two bodies about one another and this period will equal 55 of our present days. The rotations of the two bodies will then take place exactly as if they were rigidly connected, the Earth turning always the same face to the Moon and the Moon the same face to the Earth.

CHAPTER V

THE SUN

63. The Distance of the Sun.—The distance of the Earth from the Sun may be regarded as the fundamental distance in astronomy. As we shall see later, when discussing Kepler's laws governing the motions of the planets around the Sun, if the periods of these motions are known, it is only necessary to know the mean distance of the Earth from the Sun in order to be able to determine the mean distance of every planet. It is possible, in fact, from observations of the angular motions of the planets and the application of Kepler's laws of planetary motion, to draw a correct map to scale of their orbits, but the scale-value of this map will remain arbitrary until any one distance has been determined. The determination of the distance from the Sun of any other member of the solar system will suffice therefore to determine the mean distance of the Earth. This distance serves also as the base-line from which the distances of the stars may be determined.

Instead of the Sun's distance, we may alternatively use the Sun's *parallax*, this term having a meaning analogous to its meaning when applied to the Moon (§ 55), i.e. the solar parallax is the angle subtended by the radius of the Earth at the Sun. It is usually expressed in seconds of arc, having a value $8''.80$. If this is converted into circular measure and divided into the radius of the Earth, expressed in miles, the quotient gives the Sun's distance also in miles.

The solar parallax is closely related to the constant of aberration. In § 36, it was explained how Bradley discovered the apparent displacement of a star due to aberration; observations made for the purpose of measuring these displacements determine the aberration constant, which is equal to the ratio

of the mean velocity of the Earth in its orbit to the velocity of light. The velocity of light can be measured experimentally and it follows that a determination of the aberration constant in effect gives the mean orbital velocity of the Earth. Multiplying this by the number of seconds in the year gives the circumference of the Earth's orbit and hence its mean radius. The following table gives the values of the solar parallax corresponding to various values of the aberration constant :—

Aberration Constant.		Solar Parallax.
20".46	..	8".808
.48	..	.799
.50	..	.790
.52	..	.782
.54	..	.773

The determination of the Sun's distance may therefore be made by a direct method, in which the distance of any member of the solar system is found, or by an indirect method, involving the prior determination of the constant of aberration.

64. The Transit of Venus Method.—Although this method is not capable of giving results of a high order of accuracy, it is of considerable interest historically, Halley having shown in 1716 how observations of the transit of Venus could be used to determine the solar parallax.

The orbit of the planet Venus lies within that of the Earth, and being inclined at a small angle to the ecliptic, it sometimes happens that the planet comes directly between the Earth and the Sun, and it is then seen as a dark spot moving across the Sun's disc. Such an occurrence is called a transit of Venus. The transits occur at irregular and distant intervals which are alternately short and long; the short ones are always 8 years, the long ones alternately $121\frac{1}{2}$ and $105\frac{1}{2}$ years. The following are the dates of the transits between 1600 and 2200 :—

Date.	Interval.	Date.	Interval.
1631, Dec. 6.		2004, June 7.	$121\frac{1}{2}$ years.
1639, Dec. 4.	8 years.	2012, June 5.	8 "
1761, June 5.	$121\frac{1}{2}$ "	2117, Dec. 10.	$105\frac{1}{2}$ "
1769, June 3.	8 "	2125, Dec. 8.	8 "
1874, Dec. 8.	$105\frac{1}{2}$ "		
1882, Dec. 6.	8 "		

Only five transits have yet been seen, viz. those of 1639, 1761, 1769, 1874 and 1882. The first of these was predicted by a poor and unknown English curate named Horrocks who, at the time but 22 years of age, had been able to correct an error in Kepler's writings and to calculate the date of the occurrence. It so happened that the predicted date fell on a Sunday, and Horrocks was torn between his desire to make the observation, which at that time was a unique one, and to perform his duty at Church: the predicted time was uncertain within a few hours and a continuous watch was necessary in order that the transit might not be missed. He decided to put duty first and to observe in the intervals between the services, and was rewarded by seeing the black dot on the Sun's disc in the afternoon, shortly before sunset. A tablet in Westminster Abbey, with a quotation from Horrocks' work, *Venus in Sole Visa* (1662), "Ad majora avocatus quæ ob hæc parerga negligi non decuit," commemorates the observation.

The transit of 1769 was observed with a view to the determination of the solar parallax, the value obtained being $8''.57$. The two transits of the nineteenth century, in 1874 and in 1882, were extensively observed with the best appliances available, in the hope that a value would be obtained which could be accepted without question as correct.

The theory of the method will now be briefly explained. When the transits occur, Venus is at "inferior conjunction," i.e. between the Earth and the Sun, and therefore at its nearest to the Earth. Its distance from the Earth is then only about



FIG. 41.—Transit of Venus: Halley's Method.

two-sevenths of the Sun's distance, and a displacement of the observer on the Earth will cause a much greater displacement relatively to the stars of Venus than of the Sun: the circumstances of the transit will therefore vary according to the position of the observer on the Earth.

Suppose two observers on the Earth are situated at the points *A* and *B*, which are widely separated in latitude (Fig.

41). V is the position of Venus: then the apparent paths of Venus across the Sun during its transit as seen from A and B respectively are represented by aa_1 and bb_1 . If both observers are provided with accurate clocks and observe the time taken during the transits from a to a_1 and b to b_1 , it is possible to deduce the lengths of these two arcs.

The synodic period of Venus is the period of one revolution of Venus with respect to the line joining the Earth and the Sun and is known. If Venus actually moves from V to V_1 (Fig. 42) whilst apparently moving from a to a_1 , the angle VSV_1 can be calculated if the time taken is known, for angle VSV_1 : time of transit $= 360^\circ$: synodic period.

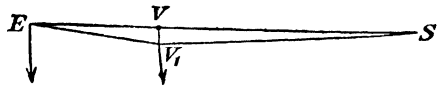

FIG. 42.—Theory of Determination of Earth's Distance from Transit of Venus Observations.

Also the *ratio* of the distances EV , SV is known, for, as has been explained, planetary observations enable the orbits of all members of the solar system to be drawn to scale. The angle VEV_1 can then be deduced, and this is equal to the length of the chord aa_1 in angular measure. Similarly bb_1 can be determined in angular measure. Since the angular diameter of the Sun is known, the distance pq between the mid-points of the two chords can be calculated in angular measure. But since the linear distance AB is known and the ratio of the distances Vp , VA , pq can also be obtained in linear measure. The knowledge of the same length in both angular and linear measure at once gives the distance between the Sun and Earth. Many refinements have to be taken into account in making the calculations, but the general principle of the method is as explained above. For the transits of 1874 and 1882 extensive preparations were made and numerous expeditions, which were organized with great thoroughness, were dispatched by the Governments of Great Britain, the United States and other countries. Although the transits were widely observed, the results were disappointing and did not greatly increase our knowledge of the solar parallax. It was found impossible to state with certainty what was the exact moment at which Venus touched the

Sun's disc, the difficulty probably arising from the existence of an atmosphere on Venus. The uncertainties in the recorded times of transit were therefore as great as 10 seconds of time.

65. Observations of Mars or Minor Planet.—The principle of this method is very simple, involving the measurement of the relative displacement of a planet as seen from two different points on the Earth whose distance apart can be calculated. In order to make the displacement as large as possible for a given base-line it is desirable to use a planet as near the Earth as possible. The planet Mars was used

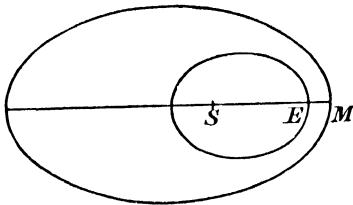

FIG. 43.—Favourable Opposition of Mars. Mars at Perihelion, Earth at Aphelion.

in 1877 by Sir David Gill, who observed from the Island of Ascension. The orbit of Mars has a high eccentricity and the most favourable time for securing the observations is therefore when Mars is at its closest approach to the Sun (i.e. at perihelion) and the Earth is near aphelion, i.e. at its greatest distance from the Sun, the two planets being at the same time in opposition, so that Mars is on the meridian near midnight (Fig. 43). The observations may then be made in one of two ways: (i) Simultaneous observations may be made from two observatories (Fig. 44), A and B , widely separated in latitude, the observations consisting in the measurement of the angular distance of Mars from one or more neighbouring stars. These enable the angle AMB to be calculated, since the star is so distant that it is seen in the same direction from A and B , so that the angle

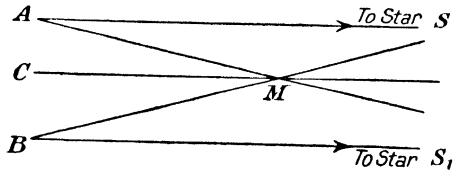

FIG. 44.—Observation of Mars from Solar Parallax.

AMB is simply the sum of the two angles MAS , MBS_1 , and then, the base-line AB being known, the distance between Mars and the Earth can be calculated: all other distances in the solar system can then be deduced. (ii) The

observations may all be made from one station. Mars being in opposition crosses its meridian near midnight and is therefore visible throughout the night. The diurnal rotation of the Earth then provides the base-line, observations being made at *A*, and again, after an interval of several hours, when the station has moved round to *B*. A correction must then be applied for the orbital motions of Mars itself, and also of the Earth between the two observations.

There are advantages and disadvantages attaching to both methods : the second method eliminates to a very large extent all errors of a personal or of an instrumental nature and involves less interruption on account of unfavourable weather. In the first method, it is easier for personal and instrumental errors to enter, and the weather conditions may be unfavourable at one station when they are favourable at the other. On the other hand, if several observatories can co-operate the accumulation of observations should give a result of greater accuracy.

Great accuracy in the observations are required, for the angles to be measured are small. Sir David Gill used a heliometer for measuring the angles, this instrument enabling angular distances in the sky to be determined with a high precision. He obtained the value $8''.78$ for the solar parallax. The chief source of error lay in the difficulty of measuring accurately the distance between the planet, whose image possesses a definite disc and a star. Gill therefore decided later to repeat the observations, using certain of the minor planets which, owing to the large eccentricities of their orbits, come sufficiently near to the earth for the purpose. He selected the planets Victoria, Iris and Sappho : these small objects appear in the telescope as star-points and the error referred to is thus avoided. He made an extensive series of observations at the Cape of Good Hope in the years 1888 and 1889 and secured the co-operation of observers at New Haven, Leipzig and Göttingen ; similar instruments being used at each place. The final result of the whole series was to give a value for the solar parallax of $8''.80$, which is the value accepted at present.

After the completion of this work, a small planet was discovered by Dr. Witt of Berlin, to which the name of Eros

was given. This planet, only 28 miles in diameter, has an orbit with a high eccentricity and at times comes to within a distance of 14 million miles from the Earth : it is therefore admirably adapted for observation for the determination of the Sun's distance. One of the close approaches of Eros to the Earth occurred in 1900 and a very extensive series of observations were undertaken in co-operation by many observatories. Long focus telescopes were employed and observations secured by photography. The results confirmed the value $8''.80$ for the solar parallax, which corresponds to a distance from the Sun to the Earth of 92,800,000 miles.

66. Other Methods for Determining the Sun's Distance.

—The methods described in the preceding section and the indirect method depending upon the determination of the aberration constant, to which reference has already been made, provide the most accurate means of determining the Sun's distance. Other methods have also been used, and although not susceptible to the same high degree of accuracy, they serve to confirm the result. As this distance is fundamental in astronomy, it is not desirable that any avenue for determining it should remain unexplored.

One method depends upon the disturbance caused by the Earth in the motion of Venus. To a first approximation the motion of Venus is in an ellipse, but when Venus and the Earth are near their distance of closest approach, the gravitational attraction of the Earth on Venus causes the latter to depart somewhat from true elliptical motion, and the observation of these perturbations provides a means of determining the mass of the Earth and through it, by Kepler's laws, of the Earth's distance. Another method depends upon the inequality in the motion of the Moon, which is termed *the parallactic inequality*. Referring to § 49, the disturbing effects of the Sun to which the variation is due are greater at any point in the portion DAC of the orbit than at the corresponding point in the portion DBC, owing to the Moon being nearer to the Sun in the former position. This second order effect is known as the parallactic inequality. It involves the Earth's mean distance from the Sun and comparison of the calculated with the observed value enables the distance to be determined.

A third method has also been applied which depends upon different principles. As will be explained in § 69, the light from a star when passed through a spectroscope is split up into separate lines whose positions are shifted slightly to the red or blue according as there is relative motion of the star and the observer away from or towards one another. The method provides a means of measuring the relative velocity of the star and observer in the line of sight. If then the Earth's orbital motion is directed at one time of the year towards a certain star, spectroscopic observations will give the difference between the velocity of the star away from the solar system and the velocity of the Earth: observations made six months later, when the Earth's motion is directed away from the star, will give the sum of these two velocities. The difference between the two measures enables the velocity of the Earth in its orbit to be determined and hence its distance from the Sun.

67. The Size and Mass of the Sun.—Having determined the mean distance of the Earth from the Sun, it is a simple matter to determine the size of the Sun. It is only necessary to measure its mean angular diameter. This is found to be 32' 4". Expressing this in circular measure and multiplying by the Earth's distance, we find that the Sun's diameter is about 865,000 miles or about 108 times the diameter of the Earth.

The determination of the mass of the Sun must naturally be based upon the previous determination of the mass of the Earth. The method of determining the latter, or its equivalent the Earth's mean density, has already been explained (§ 15). Newton's law of gravitation, together with a knowledge of the distance of the Earth from the Sun, suffice to connect together the masses of the Sun and Earth. Since the Earth attracts a body on its surface with the same force as it would if its mass were concentrated at its centre, it follows that the ratio of the forces per unit mass acting on such a body due to the attractions of the Sun (f) and Earth (g) respectively is given by

$$f/g = \frac{M}{R^2} \frac{m}{r^2},$$

where m , M are the masses of the Earth and Sun respectively, r is the Earth's radius, R the Sun's distance. The attractive force f is readily calculated. Assuming the orbit of the Earth

to be a circle, its acceleration towards the Sun at any point is known from dynamical principles to equal V^2/R , where V is the velocity of the Earth in its orbit. But since this acceleration is simply a measure of the force per unit mass, it must equal f , i.e. $f=V^2/R$. R is known and V can be found from the fact that the Earth completes one revolution (distance $2\pi R$) in one year. V is thus found to be about 18.5 miles per second, and R being nearly 93 million miles, $f=0.233$ inch per sec. per sec. In this way, by substituting this value of f in the above formula, it is found that the mass of the Sun is about 332,000 times that of the Earth.

This value can be obtained in another way. It can be shown, by dynamical principles involving Newton's law of gravitation, that for any satellite moving around a central body, the period of revolution is proportional to the distance multiplied by the square root of the distance and divided by the square root of the mass of the central body. Comparing the period of the rotation of the Earth about the Sun with that of the Moon about the Earth (the Earth being then regarded as the central body), the distance of the Earth from the Sun is about 400 times that of the distance of the Moon from the Earth and the period of the Earth about the Sun is about $13\frac{1}{2}$ times that of the Moon about the Earth. The ratio of the masses of the Sun and Earth is therefore approximately $(400 \times \sqrt{400/13\frac{1}{2}})^2$ or about 350,000. An exact calculation, allowing for disturbing factors, would give again a ratio of 332,000.

It is now possible to compare the mean densities of the Earth and Sun: the diameter of the Sun being 108 times that of the Earth, and its mass 332,000, its density is $332,000 \div (108)^3$ times that of the Earth, or approximately only one quarter as dense as the Earth. The mean density of the Earth being about 5.5, that of the Sun is only about 1.4 times that of water.

The force of gravity at the Sun's surface is considerably greater than that at the surface of the Earth. The ratio of the two forces is given by the mass of Sun divided by the square of its radius, provided that both quantities are expressed in terms of the corresponding quantities for the Earth, or is given by $332,000/(108)^2$. This ratio is about 27. The force

of gravity at the surface of the Sun is therefore about 27 times as great as at the surface of the Earth.

68. The Rotation of the Sun.—If the surface of the Sun is observed through a telescope, one or more dark spots will usually be observed on its surface. These are termed “Sun-spots” and were probably first seen by Galileo. A group of spots is shown in Plate IV (*a*). If these spots are watched from day to day, it will be noticed that they appear to move across the disc from the east limb to the west. This apparent motion is, in the main, due really to the rotation of the Sun. It is known that the spots do not, in general, remain fixed on the Sun’s surface, although their motions are slight and can be eliminated on the average when observations of a large number of spots have been accumulated. From such observations, it is found that the Sun rotates about an axis so situated that its equator is inclined at an angle of about 7° to the ecliptic and its equatorial plane cuts the ecliptic in longitudes 75° and 255° . The Sun has these longitudes on June 6 and December 6, and on these dates, therefore, the Sun’s equator projects on the Sun’s disc as a diameter: on the former date it passes west to east from below to above the ecliptic; on the latter date from above to below. At the intermediate dates, September 8 and March 8, the equator projects as a semi-ellipse, reaching 7° above and below the centre of the apparent disc respectively. The spots will appear to follow tracks parallel to the equator. When the period of rotation is deduced in this way from the motions of the spots, but only using spots appearing in a restricted range of latitude, it is found that different values are obtained for the period of rotation according to the mean latitude of the spots utilized. Therefore different parts of the Sun’s surface do not all rotate at the same rate. The period increases from the equator to the poles, and in latitude 60° is greater than at the equator by about 20 per cent. It can, moreover, be proved that this is not a phenomenon belonging to the spots themselves, but does actually belong to the solar surface. The *mean* rotation period, for the surface as a whole, was determined by Carrington as 25–38 days. The explanation of the unequal surface motion cannot yet be definitely asserted,

but it is thought that it may be due to the interior of the Sun being fluid with an increasing angular velocity of rotation inwards. If the inner strata are flattened at the poles relatively to the outer ones, they will approach nearer the surface at the equator than at the poles. Owing to their greater velocity, there will be a surface drag tending to increase the surface velocity at the equator, so that the period of rotation will be shorter there than in higher latitudes.

69. Spectroscopic Evidence as to Constitution of Sun.—

Our knowledge of the constitution of the Sun is largely derived from the evidence afforded by the spectroscope. The spectroscope (§ 104) is an instrument which analyses the vibrations which are transmitted in a beam of light and separates them into their constituent vibrations. Just as a note from a piano is complex in nature, consisting of a fundamental tone together with certain overtones, so, in general, a beam of light is composed of a number of separate light vibrations. If a beam of sunlight is passed through a prism it is spread out into a coloured band, the colours being in the order red, orange, yellow, green, blue, indigo and violet. This coloured band is called a spectrum, and to each gradation of colour corresponds a definite length of wave and period of vibration—the red end corresponding to a longer wave-length than the blue end. The spectroscope provides a more perfect means of analysis than the simple prism, and when a beam of sunlight is so analysed it is found that the bright band of light is crossed by numerous dark lines, called Fraunhofer lines, after the physicist who first mapped and discussed them.

Without going into the subject in great detail, it may be mentioned that spectra can be classified into three main classes, viz. :

(1) *Bright Line Spectra*, consisting of a number of definite bright lines. These are produced by glowing matter in a gaseous condition, e.g. by volatilizing metals in the electric arc or by passing an electric discharge through a tube containing gas under low pressure.

(2) *Dark Line Spectra*.—If a mass of glowing vapour is giving a bright line spectrum and light from a source at higher temperature is passed through it, the spectrum obtained consists of dark lines which exactly correspond in position with the

bright lines of the bright line spectrum. The explanation of the formation of this type of spectrum depends upon the law enunciated by Kirchtroff that a body will absorb radiations of the same wave-lengths as those which it emits. Light from the source at higher temperature in passing through the vapour at lower temperature loses by absorption those portions which the latter can itself emit, and passes on deprived of them. The lower temperature source is naturally also emitting vibrations, but in general these are of negligible intensity compared with those that are absorbed and appear by contrast to be absent. Such spectra may therefore be called absorption or reversal spectra.

(3) *Continuous Coloured Bands*.—Spectra of this type, containing no dark lines, are emitted by glowing solids or by glowing gases, when submitted to great pressure.

The bright line spectrum of any element is a characteristic of that element, and the presence of these lines in any other spectrum enables that element to be identified as existing in the source producing the spectrum.

The fact that the solar spectrum is a dark line spectrum indicates therefore that light from the hot interior of the Sun passes through a layer of lower temperature at the Sun's surface. The elements in this lower temperature layer can be identified from the positions of the lines in the spectrum. Rowland made a catalogue and map of most of these lines, giving the positions and intensities of about 16,000 lines, which has enabled the following elements to be identified in the Sun's outer layer or atmosphere, as we may call it :—

Iron	Neodymium	Aluminium	Bismuth (?)
Nickel	Yttrium	Cadmium	Tellurium
Titanium	Lanthanum	Rhodium	Indium
Manganese	Niobium	Erbium	Oxygen
Chromium	Molybdenum	Zinc	Tungsten
Cobalt	Palladium	Copper	Mercury (?)
Carbon	Magnesium	Silver	Helium
Vanadium	Sodium	Germanium	Ytterbium
Zirconium	Silicon	Glucinum	Europium
Cerium	Hydrogen	Tin	Radium (?)
Calcium	Strontium	Lead	
Scandium	Barium	Potassium	

The elements are arranged in this table in the order of the number of lines identified in each case ; thus, iron heads the list with over 2,000 lines. The order does not indicate the relative amounts of the various elements present in the Sun. In Plate V is shown a portion of the Sun's spectrum. This may be compared with the iron arc comparison spectrum, also shown on the plate. All the lines in this spectrum may be identified as present in the solar spectrum.

This list does not comprise all the substances contained in the Sun's atmosphere. Only about one quarter of the lines have been identified. Some belong to compounds such as cyanogen and ammonia, both of which contain nitrogen, although this element does not itself appear in the above list, no lines of the element nitrogen having yet been identified in the solar spectrum.

The identification of the lines is not, in general, a straightforward matter. Some lines may be blends and such can be ascribed to more than one element, for two elements may have a line in almost identical positions. Other lines do not correspond exactly in position with the lines as measured in a laboratory, when a terrestrial source is used, on account of various disturbing factors. Then again, many lines which appear in the solar spectrum originate through absorption in the Earth's atmosphere and are not related in any way to the Sun. The separation of the terrestrial from the solar lines can best be made by the application of what is known as Doppler's principle. If there is a relative motion of the source and observer towards or away from one another, this principle asserts that the wave-lengths of the radiations received will be shortened or lengthened respectively, the change being small but proportional to the relative velocity. The principle may be illustrated by the rise and fall in the pitch of the whistle of a train as it approaches and then recedes. During the approach, the oncoming waves are crowded together so that the length of wave is shortened. If then the spectrum of light from one limb of the Sun, at the equator, is compared with light from the opposite limb, there will be a relative displacement between the solar lines in the two spectra owing to the rotation of the Sun carrying one limb away from and the other towards the observer. Measurement of this displacement provides a

means of determining the velocity of rotation of the Sun. Lines which originate from absorption in the Earth's atmosphere occupy the same position in the spectra of both limbs and can therefore at once be distinguished from the true solar lines.

It is of interest to recall that helium was discovered by means of the spectroscope in the Sun before it was found on the Earth. Lockyer, in 1868, observed in the solar spectrum a prominent line in the yellow close to but not identical to the well-known sodium lines. It could not be assigned to any known element and was therefore ascribed to a hypothetical element helium (*ἥλιος*, the Sun).

Some years later, Ramsay, on examining the spectrum, emitted by an inert gas obtained from the mineral uraninite, found the same line and was able to identify the gas with Lockyer's helium.

70. The Surface of the Sun.—The surface of the Sun appears to us as a disc which is brighter at the centre than at the limb. This decrease in brightness from centre to limb is more easily seen in a photograph than visually, as the deficiency is greater in actinic light. It is due to the absorption in the Sun's atmosphere, the light reaching the observer from the limb of the Sun having to pass a greater distance through the Sun's atmosphere than that reaching him from the centre of the disc. In addition, the disc is seen under suitable magnification to have a mottled or granulated appearance. These mottlings may be seen either visually or in a photograph. If two photographs are taken in rapid succession the mottlings on one cannot, in general, be identified on the other. They appear to be in rapid motion, with velocities of from 5 to 20 miles per second, changing their form continually meanwhile. It is not certain what they are; Langley regarded them as tops of columns in which the heated matter from the Sun's interior rises to the surface; others regard them as of the nature of clouds. It is not even certain that their velocities represent real horizontal movements; Chevalier compared them with the white tops of waves in a choppy sea, which are always in motion, but which are composed of different particles of water at each instant.

Sun-Spots.—Sun-spots can best be studied by projecting with a telescope an enlarged image of the Sun upon a screen, or by taking a short-exposure photograph of the Sun's surface. Occasionally they are sufficiently large to be seen through a dark glass with the naked eye, but this does not permit of the detail being studied.

The typical spot consists of an umbra or dark centre surrounded by a penumbra, in the form of a more or less complete ring which is darker than the surrounding solar surface, but not so dark as the umbra. Plate IV (*a*) shows an exceptionally fine group of spots. On a positive photograph such as this, the umbra gives the appearance of a black chasm, but it must be remembered that it is dark only in comparison with the surrounding surface, for the spot, if it could be removed from the Sun, would appear of intense brightness. The detail in the spot and even its general shape change considerably from day to day.

• The spots are relatively short-lived: some appear and disappear in the course of a few days; others survive for one or two revolutions of the Sun, disappearing at one limb and reappearing 14 days later at the opposite limb, but they never last for more than a few months. With but a few exceptions, they occur only within two zones in north and south latitudes, extending from the equator to 30° . Near the spots may usually be seen bright patches on the surface which are called faculæ, though the faculæ are not necessarily related to a spot and may be observed when no spots are to be seen. A large spot usually ends by breaking up into smaller spots which gradually disappear.

The spectra of Sun-spots differ in several respects from the general solar spectrum, some lines being weakened and others strengthened. There is evidence that lines of compounds such as titanium oxide and magnesium hydride are present in their spectra: such lines do not occur in the solar spectrum and this would appear to indicate that the temperature in the spots is lower than that of the rest of the Sun, thus permitting the formation of compounds which would dissociate into their constituent elements at a higher temperature. On the other hand, it might possibly be interpreted as an indication of greater pressure in the spot.

Plate V illustrates the difference between the solar and Sun-spot spectra. The relatively greater intensity of certain lines in the spot spectrum is at once apparent. The comparison spectra of the iron arc and iron furnace are shown below. The general similarity between the furnace lines and the corresponding lines in the spot spectrum and between the arc spectrum and the corresponding lines in the Sun's spectrum is easily seen. The furnace spectrum is characteristic of a lower temperature than the arc spectrum.

It was discovered by Hale, at the Mount Wilson Observatory, that an intense magnetic field is associated with Sun-spots. This discovery was made by the application of a phenomenon predicted by Lorentz and verified by Zeeman—that if light is passed through a strong magnetic field, each single spectral line is turned into a doublet or triplet, a doublet being observed when the light is viewed in the direction of the lines of magnetic force and a triplet when viewed in the perpendicular direction. The differences in the wave-lengths of the separate components provides a means of measuring the strength of the magnetic fields. If the field is not sufficiently intense, the line is merely widened instead of being actually separated. Many of the lines in Sun-spot spectra appear widened on this account, the two sides of the line presenting the characteristics of the Zeeman resolution.

Hale also showed that many Sun-spots are surrounded by hydrogen vortices. As will be shown in § 72, it is possible to photograph the Sun's surface by means of hydrogen or calcium light and such photographs give clear evidence of the vortical motion. Plate IV (b) shows two spots near to one another, associated with vortical motion. The direction of rotation of these vortices is generally counter-clockwise in the northern hemisphere and clockwise in the southern, i.e. in the same direction as occurs in cyclonic circulation on the Earth. The two spots, to be seen in Plate IV (b), show opposite directions of rotation. The magnetic field associated with a Sun-spot is probably produced by the vortical motion of negatively-charged particles moving inwards towards the centre.

St. John has found that in the lower regions of Sun-spots the general direction of motion is radially outwards, many substances participating in the motion. In the upper levels there

is a corresponding inflow, of which calcium and hydrogen are the chief constituents.

The real cause and nature of Sun-spots must still be regarded as unknown. They are evidently violent eruptions of some sort and are doubtless indications of deep-seated disturbances. But whether they are actually eruptions from the interior, or whether they are chasms in the Sun's surface into which gases are rushing downwards, the evidence is not at present sufficient to decide.

71. The Periodicity of Sun-Spots.—If a record is kept of the number of spots visible on the Sun each day, or of their total area, it will be found that, although these figures are subject to irregular variations from day to day, if the averages are taken for fairly long periods, say for each year, the numbers so obtained oscillate in a well-defined manner. At the Royal Observatory, Greenwich, photographs of the Sun are taken on every possible day and the areas of all the spots shown on these and on other photographs obtained at the Cape of Good Hope are measured. The mean daily area of the spots so determined, expressed in units of a millionth of the Sun's visible hemisphere, are given for a number of years in the following table:—

Year.	Area Covered by Spots.	Year.	Area Covered by Spots.	Year.	Area Covered by Spots.
1889 . . .	78	1900 . . .	75	1911 . . .	64
1890 . . .	97	1901 . . .	29	1912 . . .	37
1891 . . .	421	1902 . . .	63	1913 . . .	7
1892 . . .	1,214	1903 . . .	339	1914 . . .	152
1893 . . .	1,458	1904 . . .	488	1915 . . .	697
1894 . . .	1,282	1905 . . .	1,191	1916 . . .	724
1895 . . .	974	1906 . . .	778	1917 . . .	1,537
1896 . . .	543	1907 . . .	1,082	1918 . . .	1,118
1897 . . .	514	1908 . . .	697	1919 . . .	1,052
1898 . . .	376	1909 . . .	692	1920 . . .	618
1899 . . .	111	1910 . . .	264	1921 . . .	350

It will be noticed that in 1901 there was a pronounced minimum in the mean daily spotted area, and that in succeeding years the values increased rapidly and attained a maximum in 1905. After 1905, in spite of a temporary increase in 1907, the mean spotted area gradually decreased again and reached

another minimum in 1913; after a lapse of 12 years the cycle then repeats itself, the next maximum occurring in 1917. Sun-spots have been observed and enumerated by various observers for about 300 years, and this fluctuation can be traced back throughout the records, the mean period of the cycle being between 11 and 12 years. It was first pointed out by Schwabe about the year 1843.

The distribution in latitude of the spots shows a progressive change throughout the cycle. We have already mentioned that the spots occur only in two zones extending from about

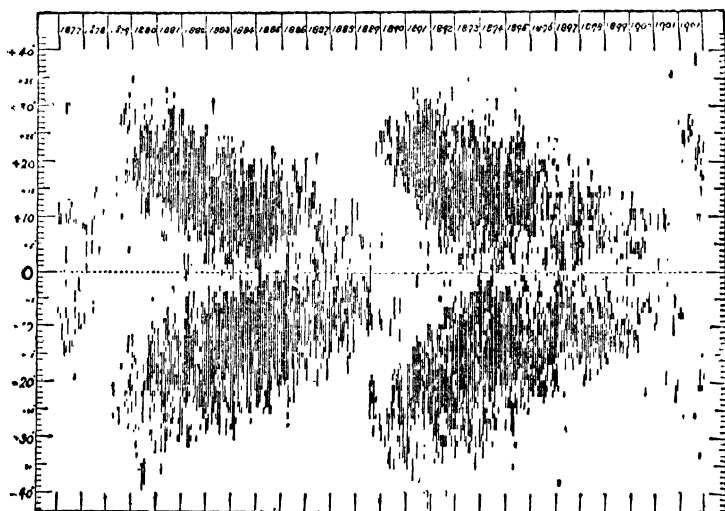

FIG. 45.—Distribution of Sun-Spots in Latitude throughout Sun-Spot Cycle.

latitudes 0° to 30° on either side of the equator. At the commencement of a cycle, when the number of Sun-spots is a minimum, the spots occur almost entirely in high latitudes; as the number of spots increases, they begin to appear in middle latitudes, entirely leaving the higher latitudes. Continuing through the cycle, the mean latitude of the spots still further decreases and a few years after maximum the spots are found almost entirely in the lower latitudes of the spot zones. At or near the time of minimum, spots again commence to appear in high latitudes and they then disappear in low latitudes.

The periodicity is well shown by Fig. 45, due to Maunder. In this diagram, abscissæ represent time and ordinates latitudes on the Sun. Corresponding to the appearance of any spot, a vertical line is drawn in the latitude range covered by the spot and with the appropriate abscissa. The figure shows at a glance the appearance of the first spots of a cycle in high latitudes, the gradual extension in latitude range as the cycle develops and the final disappearance of the spots at the end of the cycle in low latitudes. The diagram, covering two cycles, illustrates the recurrence of these phenomena.

Not only is the mean period of 11 years occupied by the cycle an irregular one, but also successive maxima and minima may differ very much in intensity. The period may be as short as 8 years or as long as 17 years; the maxima may be sharp and strongly marked or relatively flat and weak. Attempts have been made to analyse these fluctuations by representing them as due to a main period upon which are superposed several subordinate periods or harmonics. A period of 33 years has, for instance, been strongly suspected. By means of such investigations, it is possible if the existence of a sufficient number of harmonics is assumed to represent with close accuracy past Sun-spot records, but when the analysis is used to predict the future course of the Sun-spot activity, it is invariably found that the predictions are not verified. No other period than the 11-year period has, in fact, been definitely established.

There is a remarkable connection between the Sun-spot cycle and the occurrence of magnetic storms on the Earth. When Sun-spots are numerous, magnetic storms are relatively frequent; when Sun-spots are few in number, the storms are rare. The connection between them was pointed out by Maunder, who examined nineteen great magnetic storms between the years 1875 and 1903. These storms, in general, showed a sudden commencement and in every case there was a large spot near the central meridian of the Sun. Further, Maunder showed that magnetic storms frequently recur after an interval of about 27.3 days, and this is the period of the Sun's synodic revolution. If a spot is on the central meridian at a certain date, it will again be on that meridian after the lapse of 27.3 days and will then be in position to cause another storm. It must be emphasized, however, that the presence of

a large spot on the Sun is not necessarily an indication that a magnetic storm will ensue. The storm is generally held to be due to the emission of some form of electrically-charged particles from the spot ; these particles are emitted in a restricted direction not necessarily normal to the Sun's surface and if, in their passage outwards, they come into the Earth's atmosphere, electrical currents are produced in the upper layers which cause variable magnetic fields, superimposed upon the general magnetic field of the Earth. A magnetic storm is thus produced. If, on the other hand, the stream of particles does not encounter the Earth's atmosphere, a magnetic storm will not follow the passage of the spot across the central meridian of the Sun. If this theory is correct, when the stream of particles reaches the Earth, the spot should have crossed the Sun's central meridian. This is found to be the case, the average time between the meridian passage and the commencement of the storm being about 30 hours. The theory also explains why a storm will tend to be followed by another one after an interval of 27.3 days. The motion of a spot relative to the Sun's disc is small and therefore if a large spot produces a storm and survives another rotation of the Sun, it will remain in a position to produce a further storm.

) The influence of the Sun-spot activity upon the Earth's magnetism is also revealed in another way. On normal undisturbed days, the several magnetic elements do not remain absolutely constant but vary between certain limits during the course of a day. It is found that the magnitudes of the diurnal ranges of the elements vary throughout the Sun-spot cycle. If monthly means of the diurnal ranges are plotted against the time and the points joined up in order, an irregular curve is obtained ; if the local irregularities are neglected or smoothed out, the resulting curve follows closely the curve representing the monthly averages of the daily Sun-spot areas. In Fig. 46 are shown curves representing the Sun-spot frequency and the mean diurnal ranges of magnetic declination and horizontal force at Greenwich, for the period 1841 to 1896. The periodic nature of the Sun-spot frequency is clearly shown. The fidelity with which its maxima and minima are reproduced at the same epochs by the magnetic curves is surprising ; many even of the minor fluctuations are reproduced.

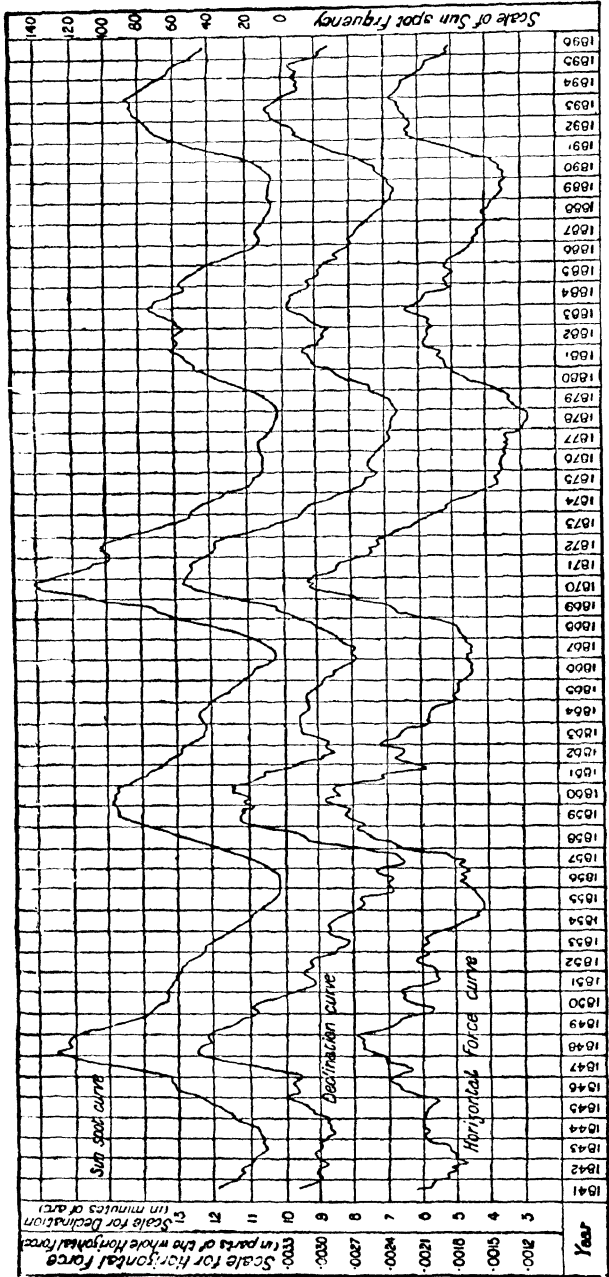

Fig. 46.—Smoothed Curves of Sun-Spot Frequency (Wolf), compared with corresponding Curves showing the Variation in Diurnal Range of the Magnetic Elements of Declination and Horizontal Force from Observations made at the Royal Observatory, Greenwich.

The actual significance of the Sun-spot cycle which, as we shall see, can be traced in other solar phenomenon, is not known. It must be the outward evidence of something of a deep-seated nature going on in the Sun. There are many stars, or other suns, whose light is variable; in some cases, the variation is due to the orbital motion of two bodies of unequal brightness, in others it is intrinsic. In some cases, the variation is perfectly regular, in others, highly irregular. It appears probable that we are justified in regarding the Sun as an irregularly variable star, with a very small range of variation. But the cause of the variation is not at present known.

72. The Spectroheliograph.—Our knowledge of the Sun's surface has been much increased by an instrument called the spectroheliograph. When the slit of a spectroscope is pointed to a certain portion of the Sun's disc, any line in the spectrum obtained indicates the presence and state of a certain element in that portion of the disc. The spectroheliograph enables the same information to be obtained for the whole disc. If the light from a certain line is allowed to pass through a second slit, in the focus of the spectroscope, on to the photographic plate, and the first slit be moved across the image of the Sun, the second slit moving correspondingly, then if the two slits are sufficiently long to extend across the image of the Sun, a photograph of the Sun will be obtained which is produced by a single radiation only. The photograph will therefore give a representation of the distribution of that substance over the Sun's surface. Alternatively, instead of moving the slits, the image of the Sun may be caused to travel slowly and uniformly across the first slit, the photographic plate moving in unison behind the second slit. This is the principle of the spectroheliograph. For most lines, very high dispersion is required to prevent the light of the adjacent continuous spectrum from blotting out the faint image. It has been found, however, that there are certain lines which appear "reversed" over certain portions of the Sun's disc, i.e. superimposed on the dark absorption line is a bright line. Typical lines showing this effect are the $H\alpha$ and $H\beta$ hydrogen lines and the K calcium line. The dark and bright lines probably represent different layers in the sun's atmosphere, the dark

line being due to absorption in a lower level and the bright line to incandescent matter at a higher level, *e.g.* such as is revealed in prominences. In taking photographs with the spectroheliograph, the bright reversals are utilized as they are easily photographed, the *H α* line of hydrogen and the *K* line of calcium being generally used. These photographs represent the distribution of calcium and hydrogen clouds in the Sun's atmosphere, and reveal many interesting phenomena. The faculæ surrounding a spot are shown much more extensively in the calcium light and were called "floculi" by Hale; they consist mainly of glowing calcium clouds. The prominences which can frequently be seen at the edge of the Sun's disc appear in the photographs in hydrogen light projected on the disc, whatever their position on the surface. The hydrogen vortices surrounding many Sun-spots are also seen in these photographs.

In Plate VI are reproduced two spectroheliograms of the Sun, photographed on the same day with the *K₃* ray of calcium and the *H α* ray of hydrogen respectively. The correspondence of the dark markings in the two photographs may be noted. On the limb near the east point is an area of faculæ, clearly shown in the photograph taken in calcium light. The coarser structure of the calcium clouds than of the hydrogen clouds is very noticeable.

73. Solar Prominences.—The subject of solar eclipses will be dealt with in detail in the next chapter. For the present, it is sufficient to remark that from time to time the Moon just obscures the Sun's disc over a certain region of the Earth and observers in such a region are then able to see the immediate surroundings of the Sun's disc. One phenomenon thus revealed is the existence of prominences or enormous tongues of flame standing out from the Sun's limb and often reaching to very great heights. For some time after the discovery of prominences, it was thought that it was only possible to observe them at the time of eclipse. At other times the glare produced by the scattering of sunlight by the Earth's atmosphere renders them invisible. In 1868, Lockyer and Janssen independently discovered that it is possible to observe them at any time, without waiting for a total eclipse. Using a spectroscope with a high dispersion, the diffused light is spread out into a band of

weak intensity which does not obscure the spectrum of the prominences, since the latter consists only of a few bright lines. If the outskirts of the limb are searched with the spectroscope, a prominence will be detected by the hydrogen lines flashing out bright and if the slit is then opened, the whole figure of the prominence may be seen! Prominences, which are not on the limb, can be detected in spectroheliograms taken in *H α* light, but it is when they reach the limbs that they can best be studied.

Much information in regard to the solar prominences has been gained in recent years. (As in the case of Sun-spots, their distribution is found to vary in the course of the Sun-spot cycle. They are found to occur predominantly in two distinct belts, both north and south of the equator. The low latitude belts are in the same latitudes as the Sun-spot zones and vary in activity in a similar manner, drawing in towards the equator and gradually dying out as the cycle progresses. The high-latitude zones decrease in activity at Sun-spot minimum, but do not then disappear and as the solar activity increases, they move towards the poles, where they die out at about the time of Sun-spot maximum. Some prominences occur in the neighbourhood of spots, but those in the high-latitude belts cannot show any such connection: it is found that the majority of those in the low-latitude belts also are not connected with spots.)

Prominences vary enormously in shape, size and behaviour. Their forms have been studied by Evershed, who has classified them into two broad groups. One main group includes small prominences in the form of rockets, bright jets and arches and metallic prominences (i.e. those whose spectra contain metallic lines). Such prominences can usually be definitely connected with a spot; the young and active spots are most frequently found associated with prominences, but old spots rarely so.

The other broad group includes the large massive forms, long groups, pyramids and columns. These types are rarely, if ever, associated with spots. They are usually long-lived and may reappear for several rotations, but frequently break up suddenly. When they break up in this manner, they are termed eruptive prominences. In 1917, a prominence was observed in Kashmir and at Kodaikanal, S. India, which in breaking up rose to a

height of 18'·5 or over half a million miles before fading away. The speed of motion was measured and the greatest velocity attained was 457 kms. per second. Such eruptions indicate the presence of powerful forces which may last for several hours and which apparently neutralize gravity, for the matter is not seen to descend again, but fades away at a great height.

In Plate VII are reproduced two photographs of prominences obtained at the total eclipse of 1919, May 29, at Sobral, in Brazil and Princes Island respectively. The interval between the two photographs was only 2 hours, but the change in the form of the prominence during this interval is very marked. This prominence was kept under observation on the day after the eclipse at the Yerkes Observatory and its break-up was observed.

The history of this prominence may be taken as characteristic of that of large eruptive prominences in general. It was first observed on the east limb on March 22; the end was in latitude -35° and it extended northwards 13° . Successive returns were observed, with one exception, until May 27, the prominence meanwhile growing gradually in height and intensity. On May 27, the crest of the prominence was seen just coming over the limb; it then extended in latitude through nearly 40° and its height was 1'·5. On the 28th, the prominence had come further into view and the height had increased to 2'·7. On the 29th, this had increased to 4'·5 and the prominence extended in latitude from -42° to 6° . The north end afterwards broke away from the limb; this occurred between the times at which Plate VII (*a*) and (*b*) were taken, and in Plate VII (*b*) the detached end is clearly seen. The streamers in the centre of the prominence descended to a spot in latitude $+6^\circ\cdot6$. At 2 h. 50 m. G.M.T. the south end of the prominence began to break away and 20 minutes later had entirely parted from the limb. After that the prominence commenced to rise rapidly, though it remained connected with the spot by faint streamers. At 3 h., its height was about 220,000 kms.; at 4 h., 250,000 kms.; at 5 h., 300,000 kms.; at 6 h., 360,000 kms.; at 7 h., 490,000 kms.; at 8 h., 670,000 kms. It was last seen at 8 h. 23 m., at a height of 760,000 kms. (17') above the surface, a distance exceeding half the diameter of the Sun. The two ends of the column were observed at each return until

August 5, the total life of the prominence therefore exceeding 4 months.

o Observation appears to indicate that prominences, even the largest, are very tenuous. If this is so, they cannot possess a temperature in the ordinary sense, but are luminous on account of the absorption of solar radiation. There is not much information available as to their speed of rotation, but the indications are that they rotate at a faster speed than the surface of the Sun, and that the speed of rotation decreases with increase of latitude.

74. The Chromosphere.—By bringing the slit of a spectroscope tangential to the Sun's limb, the existence of a layer all round the Sun of the same constitution as the prominences can be revealed. This layer is called the chromosphere. It is immediately above that portion of the Sun where the absorption which produces the dark Fraunhofer lines mainly takes place. The chromosphere can be most favourably studied at the time of a total solar eclipse. As the Moon moves in front of the Sun's disc, just before totality commences, the absorbing layer is covered and if the limb of the Sun is being examined with a spectroscope it is seen that a bright line spectrum appears for an instant. This "flash" spectrum, as it is termed, is the spectrum of the chromosphere. Immediately afterwards, the chromosphere itself is blotted out. Similarly, immediately after totality, the flash spectrum may again be observed.

The chromosphere contains most of the elements which are found in the Sun : its bright line spectrum is not, however, an exact replica of the dark line spectrum of the Sun. There are differences, due to the physical conditions in the two cases not being the same. Thus, for example, the bright lines of helium are found in the chromospheric spectrum, whereas dark helium lines have not been detected in the Fraunhofer spectrum. Lines of some elements such as hydrogen, titanium, chromium, etc., though found in the solar spectrum, are relatively stronger in the chromospheric spectrum, whilst, on the other hand, the lines of such elements as iron, nickel, cobalt, manganese and sodium are relatively stronger in the solar than in the chromospheric spectrum. The differences in intensity are accentuated in the case of what are termed *enhanced* lines. These are lines

which, in the laboratory, are found to be more intense in the spark spectrum of an element than in its arc spectrum, from which they may even be absent, and, for this reason, their increased brilliancy in the spark spectrum is generally regarded as the effect of the increased temperature. This can hardly be the cause which increases their intensity in the chromosphere; it appears more probable that in this case the enhanced lines are due to ionised atoms at a relatively great height, so that the pressure is much reduced.

The absorbing layer which produces the dark lines of the Fraunhofer spectrum is generally called the "reversing" layer: it is immediately beneath the chromosphere but mingles gradually with it, so that the two cannot be sharply separated. The reversing layer might, in fact, be regarded as the lower layer of the chromosphere. By using a slitless spectroscope, the lines in the flash spectrum appear as curved arcs of different lengths and by measuring the lengths of these arcs, the depth of the chromospheric layer may be calculated. It is found to extend up to a height varying from about 6,000 to 14,000 kilometres above the photosphere. The reversing layer to which most of the lines of the flash spectrum are due has a depth of from 600 to 1,000 kilometres.

75. The Corona.—At the time of a total solar eclipse, the instant totality commences a bright *aureole* surrounding the Sun flashes out. This is called the "corona." Its light is relatively so faint that no method has been discovered by which it can be observed at any other time than during totality. The light of the corona is pearly white and somewhat brighter than the light of the full moon.) On long exposure photographs, the corona is sometimes found to extend from the Sun to a distance of two or three solar diameters. The structure of the corona is very complex; it has no definite boundary and is usually symmetrical with respect neither to the centre of the Sun nor to the Sun's polar axis. Its general shape is found to vary with the Sun-spot cycle in a very marked way. At a time of Sun-spot maximum, it is compact, without very long streamers and more or less uniformly distributed around the Sun's disc, so that the direction of the Sun's polar axis is not specially indicated. At a time of Sun-spot minimum, on the

other hand, the two poles are indicated by a number of short streamers or tufts issuing from them and suggesting lines of force near the two poles of a bar magnet : from the equatorial zones stretch curved streamers, reaching to great distances. Such a corona is shown in Plate VIII (*b*), Sun-spot activity being a minimum in 1901. At other times the form of the corona is intermediate between these two types. The corona in Plate VIII (*a*) was photographed shortly after Sun-spot maximum and is of intermediate type. It will be noticed that the polar tufts are much less prominent than in the corona of 1901. So regularly do the types recur, that it is possible to predict with considerable accuracy the form of corona which may be expected at a future eclipse. It may be mentioned that the existence of the polar tufts corresponds with the time when the high-latitude prominence zones die away, whilst when the prominences reach the poles, the uniform type of corona occurs.

The structure of the inner corona is very complicated, showing numerous filaments and curved arches, especially in the neighbourhood of prominences or spots which are at or near the limb. The corona of 1901 (Plate VIII [*b*]) shows very interesting detail in the inner corona. It is not known whether this structure persists for any length of time or changes rapidly.

The light from the corona has been found to be partially polarized, i.e. the vibrations which constitute it show a predominance for certain directions instead of occurring in all directions at random. This is known to be a characteristic of light reflected from small particles. Much of the coronal light is, therefore, reflected sunlight. The spectrum of the corona consists of a number of bright lines, superposed upon a faint continuous background. These bright lines do not correspond with the lines of any known element and they have therefore been attributed to a hypothetical element which has been named coronium. A line in the green part of the spectrum is usually very prominent in the coronal spectrum, but in the eclipse of 1914, this line was scarcely visible and a previously unknown line in the red region was very prominent.

76. Solar Radiation and Temperature.—The determination of the temperature of the Sun is closely bound up with the determination of what is termed the *solar constant*. The

Sun is continually radiating energy into space and of this energy only a small part is intercepted by the Earth and planets, the remainder passing outwards into space. Of that portion which falls on the Earth, a large part is absorbed by the Earth's atmosphere. The solar constant is defined as the quantity of heat, measured in calories, which would fall in one minute on an area of one square centimetre placed perpendicularly to the radiation at the surface of the Earth, if the Earth had no atmosphere and was at its mean distance from the Sun. The determination of the constant comprises two essentially different problems: first, the determination of the amount of energy actually falling on unit area at the Earth's surface in one minute; secondly, the determination of the absorption of energy in the Earth's atmosphere. The method adopted for determining the actual amount of energy per unit area at the Earth's surface consists in allowing the radiation to fall on a body which absorbs it and measuring the quantity of heat gained by the body during a certain time. To enable the measurement to be performed accurately and to avoid possibilities of error, a specially designed instrument called the pyrheliometer is used. The measurement of the absorption in the Earth's atmosphere is a more difficult problem. The principle employed consists in measuring the radiation at different times of day: the length of the path of the light through the Earth's atmosphere decreases from sunrise to mid-day and then increases again until sunset. From the variations in the amount of radiation passing through with change in length of path the total absorption can be estimated. It is advantageous to make the observations at a high altitude, as then the loss by absorption when the Sun reaches the meridian will be relatively small. This method suffers from the disadvantage that the light is treated as though homogeneous, whereas in fact the absorption differs in amount for the different wave-lengths. Langley devised a method to overcome this defect: he employed an instrument called a spectroheliometer, which measures the distribution of energy amongst the different wave-lengths. If then observations are taken with this instrument for various altitudes of the Sun and the total energy received is measured with the pyrheliometer, the total correction to allow for absorption can be calculated.

Langley's work has been continued by Abbot and Fowle, who find for the mean value of the solar constant 1.93 calories. They have shown that this value changes slightly from day to day, the changes being confirmed by simultaneous observations made at two different stations. The value of the constant is greater at the time of Sun-spot maximum than at Sun-spot minimum, but superimposed on this variation are fluctuations of shorter period, the cause of which are still being investigated.

The value of the solar constant having been determined, the total amount of energy emitted by the Sun can be calculated. Imagine a sphere of radius 93 million miles, with the Sun at its centre. Then each square centimetre of the surface of this sphere receives in one minute 1.93 calories, all of which is radiated from the Sun. Since the surface of the Sun is 1/46000th of the outer sphere, each square centimetre of the Sun's surface must radiate heat at the rate of $1.93 \times 46,000$ or 89,000 calories per minute. Every square centimetre thus radiates at the rate of a 9 H.P. engine.

The *effective temperature* of the Sun can be calculated when the solar constant is known. By this term is meant the temperature of a perfect radiator (the so-called "black" body) of the same size as the Sun which is emitting radiation at the same rate: such a body would absorb all the radiation falling upon it without reflecting (hence the term black) or transmitting any. The radiation of a black body is proportional to the fourth power of its temperature (Stefan's Law), so that when the total radiation is known, the effective temperature can be determined. It is found to be about $5,600^{\circ}\text{C}$. The actual temperature of the Sun cannot be less than this value: the temperature of the photosphere is probably somewhat, though not greatly, higher than $5,600^{\circ}\text{C}$. The interior temperature, of course, must be very much higher. The temperature may be compared with that of the electric arc, which is about $3,700^{\circ}\text{C}$.

77. Maintenance of the Sun's Heat.—We have seen that each square centimetre of the Sun's surface is continuously radiating energy at the rate of a 9 H.P. engine: this figure corresponds to the enormous total rate of radiation of

0.58×10^{24} horse power. If this energy were derived solely from the internal store of heat in the Sun, its temperature would fall by more than one degree each year. If this were so, the future life of the Sun—regarded as a source of heat—would be only a few thousand years. We know, on the other hand, from geological considerations that organic life has existed on the Earth for many millions of years and during that period the temperature of the Sun cannot have decreased at a rate nearly approaching one degree per year. On the contrary, the evidence points to the temperature not having greatly altered during that period. There must, therefore, be some means by which the Sun is able to replenish its store of heat. By what process this is achieved has for many years been a matter of controversy.

The theory propounded by Mayer supposed the heat to come from the impact of meteors on the Sun. A meteor pulled from a great distance into the Sun would acquire a velocity of 400 miles per second and its energy would, by the collision, be transformed into heat. A quantitative calculation shows that this theory is untenable: on any plausible assumption as to the quantity of meteors which might be drawn into the Sun, the heat so produced would be but an infinitesimal fraction of the amount required. Helmholtz proposed an alternative theory: the attractive force of the Sun as a whole on a particle at its surface will tend to pull it inwards, and as the Sun is gaseous, it follows that it will gradually contract under the influence of its own gravitation. The effect of this contraction will be to generate heat, the process being analogous to the generation of heat by the impact of meteors, the meteors now being replaced by the outer layers of the Sun which are gradually falling in towards the centre. Helmholtz calculated that a diminution in the Sun's radius of 75 metres per year would liberate sufficient energy to balance that radiated as heat. Such a contraction would only produce a decrease in the Sun's apparent radius of one second of arc in 29,500 years, and therefore could not be detected at the present time by astronomical observation. Supposing this rate of contraction to continue unaltered, the Sun would contract until its density was equal to that of the Earth in another 17 million years, and we should be forced to the conclusion that the Earth would not receive

sufficient heat to maintain life on its surface for many million years longer.

We can, however, probe backwards and inquire how long the Sun can have been radiating heat at its present rate. If we suppose that there was a stage when the matter composing the Sun was dissipated in the form of a very tenuous nebula, it may be calculated that to reach its present state would only have required about 22 million years. The Earth is supposed to have been formed in the distant past from the Sun, so that this figure should give an upper limit for the age of the Earth. This period is not nearly sufficient to account for the geological processes which have taken place in the Earth, and many lines of argument based upon geological considerations combine in requiring a much longer period. Other sources of energy must, therefore, be looked for: after the discovery of radium and of the fact that one gram of radium is continually radiating heat at the rate of 138 calories per hour, it was thought that liberation of heat by radio-active processes in the Sun might account for the maintenance of the Sun's radiation. Although the existence of radium in the Sun has not been definitely established, one of the transformation products resulting from the disintegration of radium, viz. helium, is known to be present in the Sun. If each cubic metre of the Sun contained 3.6 grams of radium, the present rate of radiation of the Sun could be accounted for in this way alone. It is now believed that the energy obtained from radio-active processes can be comparatively unimportant. Rutherford has shown that if the Sun were made entirely of uranium, only about 5 million years would be added to its duration as a heat-giver. Other speculations have been advanced as to the source of the Sun's heat, but no known cause is capable of accounting for the age required by geological considerations. It seems probable that it must be attributed to a process which is capable of liberating energy at the high temperatures (of the order of millions of degrees) which prevail in the interior of the Sun, but with which we are unacquainted in the laboratory. The mutual destruction of electrons by collision, resulting in the transformation of their mass into energy, has been suggested as one possible process, but at present this can only be regarded as plausible speculation. Nevertheless, it is certain that to account for the age

of the Earth required by geologists—of the order of 300 million years—no other alternative is open to us but to suppose that some such sub-atomic process is occurring, which is conditioned by the enormously high temperature existing in the interior of the Sun.

CHAPTER VI

ECLIPSES AND OCCULTATIONS

78. **Cause of Eclipses.**—If the orbit of the Moon were in the ecliptic, so that the Sun, Moon and Earth all moved in the same plane, then twice in each lunation, the Moon would cross the line joining the centres of the Earth and Sun, the times of crossing being the times of conjunction (new moon) and opposition (full moon).

Referring to Fig. 47, it will be seen that at opposition, the shadow of the Earth E cast by the Sun S would then fall on the

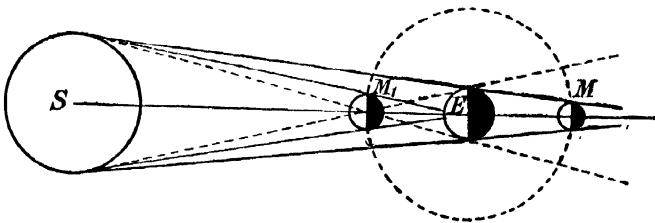

FIG. 47.—The Occurrence of Eclipses of Sun and Moon.

Moon M , and a simple calculation, involving the relative sizes and distances of the three bodies, will show that at the distance of the Moon, the diameter of the shadow cone is greater than the diameter of the Moon. Since the Moon is not self-luminous, it would therefore be completely blotted out or eclipsed. The eclipse would be visible at all places on the hemisphere of the Earth which is turned away from the Sun.

At conjunction, the shadow of the Moon might or might not fall on the Earth according to the distance of the Moon M . Should it do so at every place on the Earth within this shadow,

the Moon would completely obscure the Sun, so that there would be a total solar eclipse. It is apparent without calculation that the eclipse will not be visible over an entire hemisphere of the Earth. In order that the shadow cone of the Moon might at the distance of the Earth have a greater diameter than that of the Earth, the Moon would obviously need to be larger than the Earth. A total solar eclipse can, in fact, only be visible within a comparatively small region of the Earth's surface. At adjacent points, the Moon will only partially obscure the Sun's disc, and at such points there is said to be a partial solar eclipse.

Owing to the variation in the distance of the Moon from the Earth, the apex of the Moon's shadow cone occasionally falls between the Moon and the Earth. In such cases, the eclipse is not total at any point on the Earth's surface, but at all points on the Earth within the continuation of the shadow cone the Moon will be seen projected upon the Sun's disc, but it will be of smaller apparent diameters and its black disc will, therefore, appear surrounded by a narrow, bright ring. Such an eclipse is called an annular eclipse.

If, then, the orbit of the Moon were in the ecliptic there would be a total lunar eclipse and a total or annular solar eclipse once in each lunation. We know, however, that the orbit of the Moon is inclined at an angle of $5^{\circ} 9'$ to the ecliptic and as the angular diameter of the Moon is only about $30'$, there can be no eclipse either at conjunction or at opposition unless the centre of the Moon is within an angular distance of about $30'$ from the ecliptic. The Moon will, therefore, in general pass either under or over the common tangent cone of the Earth and Sun. For an eclipse to be possible the Moon must be sufficiently near to one of the nodes of its orbit.

To ascertain when an eclipse will occur, the times of lunar conjunctions and oppositions must be first determined. These are the times of new and full moon and occur when the geocentric longitudes of the Sun and Moon (i.e. the longitudes as measured by an observer at the centre of the Earth) are equal or differ by 180° . The positions of the Moon in its orbit at these times must be found, and if it is within certain limits of angular distance from a node an eclipse is possible. Such limits are called *eclipse limits*.

79. The Saros.—It follows, from the previous section, that if for certain positions of the Sun, the Moon and the node of the Moon's orbit an eclipse can occur, then another eclipse would occur if they returned again to their same relative positions. It can easily be shown that they will return in this way after a period of 18 years and 11 days. This period is called the *Saros* and was known to the Chaldeans and used by them for predicting eclipses. Although they had no accurate tables of the Sun and Moon, they were nevertheless able to foretell with considerable accuracy the occurrence of an eclipse. The period is still used as a rapid means of deciding at which conjunctions or oppositions eclipses will occur, the precise data of the eclipse being then calculated by modern methods.

The Saros period can be verified as follows:—

The period of revolution of the Moon relative to the Sun
= 29.53059 days.

The period of revolution of the node relative to the Sun
= 346.62 days.

For since the daily retrograde motion of the node is $3' 10.64''$ and the mean motion of the sun is $59' 8.33''$, the relative daily motion is $62' 19''$, requiring 346.62 days for a complete revolution. Two hundred and twenty-three lunations therefore occupy 6,585.32 days, and 19 synodic revolutions of the node occupy 6,585.78 days. These periods are very nearly equal, so that after 223 lunations or 18 years, 11 days (or 18 years, 10 days, if 5 leap years intervene), the Sun, Moon and node return to the same relative positions.

The following table gives the dates of lunar and solar eclipses for the years 1914 to 1950 inclusive:—

Year.	Ascending Node.		Descending Node.	
	Moon.	Sun.	Moon.	Sun.
1914	March 11	Feb. 25	Sept. 4	Aug. 21
1915	—	Feb. 14	—	Aug. 10
1916	Jan. 20	{ Feb. 3 } { Dec. 24 }	July 15	July 30
1917	{ Jan. 8 } { Dec. 28 }	{ Jan. 23 } { Dec. 14 }	July 4	{ June 19 } { July 19 }
1918	—	Dec. 3	June 24	June 8
1919	Nov. 8	Nov. 22	—	May 29
1920	Oct. 27	Nov. 10	May 3	May 18
1921	Oct. 16	Oct. 1	Apr. 22	Apr. 8
1922	—	Sept. 21	—	March 28
1923	Aug. 26	Sept. 10	March 3	March 17
1924	Aug. 14	{ July 31 } { Aug. 30 }	Feb. 20	March 5
1925	Aug. 4	July 20	Feb. 8	Jan. 24
1926	—	July 9	—	Jan. 14
1927	June 15	June 29	Dec. 8	{ Jan. 3 } { Dec. 24 }
1928	June 3	{ May 19 } { June 17 }	Nov. 27	Nov. 12
1929	—	May 9	—	Nov. 1
1930	April 13	April 28	Oct. 7	Oct. 21
1931	April 2	April 18	Sept. 26	{ Sept. 12 } { Oct. 11 }
1932	March 22	March 7	Sept. 14	Aug. 31
1933	—	Feb. 24	—	Aug. 21
1934	Jan. 30	Feb. 14	July 26	Aug. 10
1935	Jan. 19	{ Jan. 5 } { Feb. 3 } { Dec. 25 }	July 16	{ June 30 } { July 30 }
1936	Jan. 8	Dec. 13	July 4	June 19
1937	Nov. 18	Dec. 2	—	June 6
1938	Nov. 7	Nov. 22	May 14	May 29
1939	Oct. 28	Oct. 12	May 3	April 19
1940	—	Oct. 1	—	April 7
1941	Sept. 5	Sept. 21	March 13	March 27
1942	Aug. 26	{ Aug. 12 } { Sept. 10 }	March 3	March 16
1943	Aug. 15	Aug. 1	Feb. 20	Feb. 4
1944	—	July 20	—	Jan. 25
1945	June 25	July 9	Dec. 19	Jan. 14
1946	June 14	{ May 30 } { June 29 }	Dec. 8	{ Jan. 3 } { Nov. 23 }
1947	June 3	May 20	—	Nov. 12
1948	April 23	May 9	—	Nov. 1
1949	April 13	April 28	Oct. 7	Oct. 21
1950	April 2	March 18	Sept. 26	Sept. 12

The table comprises two complete Saros periods and an inspection of it will illustrate the manner in which the eclipses repeat themselves after an interval of 18 years, 11 days.

80. The Number of Eclipses in one Year.—In order that a lunar eclipse may occur, the distance of the Moon from one of its nodes, at the moment of full moon, must not exceed $12\frac{1}{2}^{\circ}$. This expresses the condition that the latitude of the Moon's centre should be equal to the sum of the angular semi-diameters of the Moon and of the shadow-cone of the Earth: for the latitude of the Moon when $12\frac{1}{2}^{\circ}$ from a node is 64', the maximum semi-diameter of the shadow is 47' and the maximum semi-diameter of the Moon is 17'. If, then, the Moon is farther from the node than $12\frac{1}{2}^{\circ}$, that limb of the Moon which is nearest the ecliptic cannot come within the shadow. It can also be shown that, if the distance of the Moon from a node be less than 9° , there must certainly be a lunar eclipse, for in such case, the latitude of the Moon's centre will be less than 52' or less than the sum of the minimum semi-diameters of the shadow (38') and of the Moon (14'). The two distances of the Moon from a node at conjunction within the lesser of which an eclipse must occur and beyond the greater of which an eclipse is impossible are called the lunar ecliptic limits. If the distance of the Moon from a node at opposition lies between these limits an eclipse may or may not occur, according to the value of the diameters of the shadow-cone and of the Moon at the instant.

Similarly, in order that a solar eclipse may be possible, the angular distance of the centre of the Sun from one of the Moon's nodes must not exceed $18\frac{1}{2}^{\circ}$, and if the distance is less than $13\frac{1}{2}^{\circ}$ there will certainly be an eclipse. These are the solar ecliptic limits.

Using these limits, we can discuss the number of eclipses that are possible in one year.

We have seen that the daily relative motion of the Sun and the Moon's node is $62' 19''$; it follows that in $14\frac{3}{4}$ days, which is the interval between full moon and new moon, the Sun and the node will separate by $15\frac{1}{2}^{\circ}$.

If, then, conjunction occurs exactly at the node there will be a solar eclipse; at the preceding and following oppositions the Moon will be $15\frac{3}{8}^{\circ}$ from its node; this distance being outside

the lunar ecliptic limit, there will not be a lunar eclipse at either of these oppositions. Hence near the passage of the Sun through the node, there will be one solar, but no lunar eclipses.

If, on the other hand, opposition occurs exactly at the node there will be a lunar eclipse; at the preceding and following conjunctions, the Moon will be within the superior solar ecliptic limit, so that at both conjunctions a solar eclipse *may* occur. Corresponding therefore to the passage of the Sun through the node in this case, there may be two solar and will be one lunar eclipse.

The same results can easily be shown to hold, if conjunction or opposition occur within 2 days on either side of the node.

Now the Sun takes 173 days to pass from one node to the other, and six lunations occupy 177 days. If, therefore, a lunar eclipse occurs exactly at one node, there may be two solar eclipses near that node, and there will also be another lunar eclipse 4 days after the Sun passes through the next node, but the Sun is then too far from the node for three eclipses to happen near that node, though one solar eclipse may happen at the preceding new moon. If, however, a lunar eclipse happens 2 days before the Sun reaches a node, there will be a lunar eclipse at the next node 2 days after the Sun has passed it. It is possible, then, for three eclipses to occur at each node. The Sun returns again to the first node and opposition will occur 6 days after its passage through the node: this will give a lunar eclipse and also a solar eclipse at the preceding new moon, but a solar eclipse at the subsequent new moon is impossible.

Now the solar eclipse at this new moon will occur exactly 12 lunations later than the first solar eclipse of the two groups of three, which we have mentioned. But 12 lunations occupy 354 days, so that if the first eclipse occurs early in January, it is possible to have seven eclipses within the year. Further, $12\frac{1}{2}$ lunations occupy $368\frac{3}{4}$ days, so that the eighth eclipse cannot come in. If we shift the whole series back so as to bring in this lunar eclipse, the first solar eclipse would be displaced unto the December of the previous year. We may, therefore, have either 5 solar and 2 lunar or 4 solar and 3 lunar eclipses within a year, but it is not possible to have more than 7 eclipses in all in any one year.

By similar considerations, it may be shown that it is possible to have a single solar eclipse near one node followed by a single solar eclipse near the other node. There cannot be less than one eclipse at each node. Therefore, there cannot be fewer than two eclipses in any year and if only two occur, both will be solar.

These conclusions are illustrated by the table in § 79. This table comprises two Saros periods and one year in each has 7 eclipses, 1917 having 3 lunar and 4 solar eclipses and 1935 2 lunar and 5 solar eclipses. In no year are there fewer than 2 eclipses and when there are only two these are invariably both solar eclipses.

Owing to the solar ecliptic limit being larger than the lunar, there must be more solar than lunar eclipses. In the Saros period there are in fact, on the average, 41 solar eclipses and 29 lunar eclipses. The number of solar eclipses visible at any given spot on the Earth's surface is, nevertheless, fewer than the number of lunar eclipses. This is due to the latter being visible over one half of the Earth's surface, whilst the former are visible only over a small portion.

The table in § 79 shows how the eclipses occur at two seasons of the year separated by an interval of nearly 6 months: these periods correspond to the passage of the Sun through the nodes of the Moon's orbit. Owing to the retrograde motion of the nodes, each eclipse season occurs *on the average* about 19 days earlier than in the previous year.

81. Recurrence of Eclipses.—Mention has already been made of the Saros period of 18 years, 11 days, after which eclipses occur very nearly in the same order. It is of interest to note further that in this period the longitude of the Sun increases by only 11° and the distance of the Moon from its perigee has changed by less than 3° : the recurring eclipses are therefore nearly of the same kind, total, annular or partial, for a number of returns.

Considering the recurrence of any particular solar eclipse in successive cycles, an eclipse will first occur when the line of conjunction makes an angle of about 16° with the line of nodes: the Moon will then just touch the shadow-cone and the eclipse will therefore be a small partial eclipse, visible necessarily

only in very high north or south latitudes. After a period of 18 years, 11 days, the eclipse will recur, but the line of conjunction will then be nearly half a degree nearer the line of nodes, on account of the half-day difference in length between the 223 lunations and the 19 synodic revolutions of the node which constitute the Saros cycle. The eclipse will again be partial. These partial eclipses will recur until after about ten cycles the line of conjunction makes a sufficiently small angle with the line of nodes, and the eclipse will then be total, but visible only in polar regions. The eclipse in successive returns will continue to be total, but will occur nearer and nearer the equator until the line of conjunction passes near the node: the path of totality will then cross in the equatorial regions. This occurs after about 22 cycles. A further 22 cycles will take the eclipse to the opposite pole, the series of total eclipses then ending and being succeeded by about 10 partial eclipses. There will therefore be in all about 20 partial eclipses and 44 or 45 total eclipses, the cycle comprising altogether about 1,200 years.

82. **Lunar Eclipses.**—In Fig. 48, S and E represent the centres of the Sun and Earth respectively and AC , BD the common external tangents, AD , BC the internal tangents to the sections of the Sun and Moon by the plane of the paper. At any point in the cone CPD , the Earth entirely cuts off the

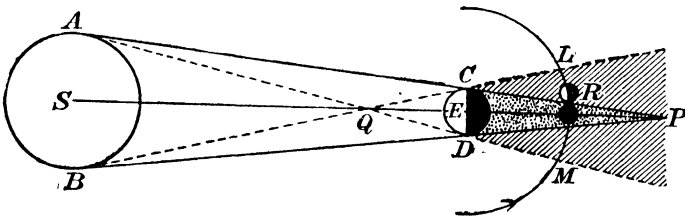

FIG. 48.—To illustrate a Lunar Eclipse.

light from the Sun: this portion of the shadow is called the *umbra*. Between the umbra and the cone, bounded by the internal tangents, is a region at any point of which the light from only a portion of the Sun is cut off: this portion of the shadow is called the *penumbra*.

When the limb of the Moon enters the penumbra at L , there

is a gradual fading of its light which does not become very noticeable to the naked eye until the Moon reaches the umbra at R : the limb then rapidly darkens and becomes invisible. Near totality, the outline again becomes visible owing to illumination of the Moon by light from the Sun which has been refracted in the Earth's atmosphere. The absorption of the short wave-lengths in the passage of the light through the atmosphere, gives the Moon a reddish or coppery colour. The brightness of this illumination varies in different eclipses on account of the varying conditions under which the light passes through our atmosphere, which at some times contains much more cloud than at others.

The duration of the eclipse depends upon the distance of the line of opposition from the node; if the distance is small, the Moon will pass almost centrally through the shadow and totality may reach 3 hours; if larger, totality may only just occur.

The calculation of the details of an eclipse of the Moon cannot be described in detail here, but the method may be outlined: the condition for an eclipse to occur is that the angular distance between the centres of the Moon and shadow as seen from the centre of the Earth may be less than

$$\begin{aligned} & \text{Moon's semi-diameter} + \angle REP \\ \text{or } & \angle \text{Moon's semi-diameter} + \angle CRE - \angle EPC \\ \text{or } & \angle \text{Moon's semi-diam.} + \angle CRE - \angle AES + \angle EAC. \end{aligned}$$

But $\angle CRE$ is the Moon's parallax, $\angle AES$ is the Sun's angular semi-diameter and $\angle EAC$ is the Sun's parallax. Hence the angular distance between the centres of the Moon and the shadow must be less than

$\text{Moon's semi-diam.} + \text{Moon's parallax} + \text{Sun's parallax} - \text{Sun's semi-diam.}$
 In evaluating this expression it is customary to increase the diameter of the Earth's shadow at the distance of the Moon by 2 per cent. to allow for the absorption in the Earth's atmosphere, making the effective diameter of the Earth larger than its true value. All the quantities in the above expression are known, so that the limiting distance between the centres of the Moon and shadow for an eclipse to occur is determined.

To determine the circumstances of the eclipse, we require to know the hourly motions of the Sun and the Moon in longitude and that of the Moon in latitude. The difference in the

motions in longitude of the Moon and Sun gives the motion in longitude of the Moon relative to the centre of the shadow. If in Fig. 49, S is the centre of the shadow, SV the ecliptic, M the centre of the Moon at the instant of opposition, MV the path of the Moon relative to the centre of the shadow, then

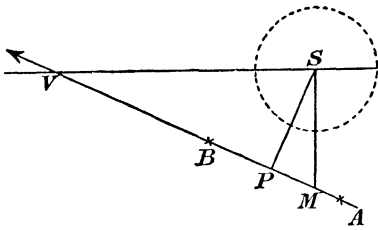

FIG. 49.—Calculation of a Lunar Eclipse.

MS is proportional to the Moon's hourly motion in latitude and SV to its motion in longitude relative to the shadow.

If AB are points on MV , so that SA and SB equal the sum of the semi-diameters of the Moon and shadow, then the eclipse

commences when the centre of the Moon reaches A and finishes when it reaches B . If SP is the perpendicular from S on MV , P is the position of closest approach. If the difference between the semi-diameter of the shadow and SP is greater than the radius of the Moon, the eclipse will be total, if less it will be partial. The distance of the centres at any time t after opposition can be readily written down in terms of t : by placing this distance equal to SA and solving for t , the times of commencement and ending of the eclipse are obtained: by placing it equal to the difference of the semi-diameters of the Moon and shadow, the times of the beginning and end of totality are obtained.

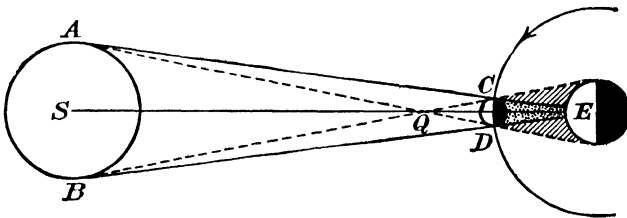

FIG. 50.—To illustrate a Solar Eclipse.

83. Solar Eclipses.—In Fig. 50, S , E represent the centres of Sun and Earth respectively and CD is the Moon. P (not marked in the figure) is the vertex of the cone formed by the external tangents to the Sun and Moon, Q the vertex of that

cone formed by the internal tangents. If P falls within the Earth, then at the points on the Earth's surface inside this cone the Sun's light is wholly cut off by the Moon and there is a total solar eclipse. The relative distances and sizes of the Sun and Moon are such that P falls sometimes within and sometimes without the Earth's surface, but in the former case, the cross section of the cone is never more than a few score miles. If P falls outside the Earth's surface, then at points within the angle of the cone (produced) an annular eclipse is seen, the apparent diameter of the disc of the Moon being smaller than that of the Sun. At points outside the zone of totality, but within the cone formed by the internal tangents, the eclipse is only partial.

The Sun and Moon being in relative motion, the shadow cone in the case of a total eclipse sweeps across the Earth, giving a narrow band within which, at different times, the eclipse is total. The duration of totality at any one place is never more than a few minutes, the maximum possible duration being 7 m. 30 s. On July 5, 2168, will occur an eclipse with almost the maximum duration, 7 m. 28 s. Owing to the small region of the Earth's surface at which a total eclipse is visible, the occurrence of a total eclipse at any given place is very infrequent. In the British Isles, there have been total eclipses over some part within the last 500 years: on 1424, June 26; 1433, June 17; 1598, March 6; 1652, April 8; 1715, May 2; 1724, May 22. There will be other total eclipses on 1927, June 29, and 1999, August 11. The former of these will occur soon after sunrise, and will be visible in the north of England, with a very short duration. The latter will be total near Land's End.

The condition that a solar eclipse may take place at or near conjunction may be determined as follows, with the aid of Fig. 51. For an eclipse to occur the angular distance between the centres of the Sun and Moon must be less than the sum of the Moon's semi-diameter and the angle SEL , i.e. less than

$$\text{Moon's semi-diam.} + \angle ELC + \angle LVE,$$

where V is the point of intersection of AC and BD ,

$$\text{i.e. } \angle \text{Moon's semi-diam.} + \text{Moon's parallax} + \angle AES - \angle EAC,$$

$$\text{or } \angle \text{Moon's semi-diam.} + \text{Moon's parallax} + \odot\text{'s semi-diam.} \\ - \odot\text{'s parallax.}$$

The computation of the times of beginning and ending of the eclipse generally can be made in the same way as in the case of an eclipse of the Moon. To compute the circumstances of the phenomenon for any particular place on the Earth's

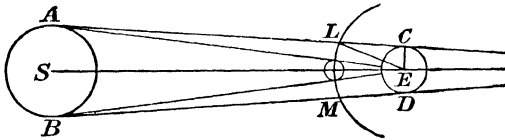

FIG. 51.—Theory of a Solar Eclipse.

surface is naturally a much more complicated problem. It comprises two parts; supposing the Earth fixed, the path of the shadow across it can be determined when the hourly motions in longitude of the Sun and in longitude and latitude of the Moon, their parallaxes and diameters are known. The modifications produced by the rotation of the Earth must then be taken into account.

The circumstances of a total solar eclipse are represented in the *Nautical Almanac* in a diagram similar to that in Fig. 52, which represents the eclipse of 1919, May 28–29. When the shadow first meets the Earth, at the point denoted by First Contact, the shadow cone will be tangential to the Earth at that point; the Sun and Moon are therefore just below the horizon at the point, so that the Sun will be just rising there and the eclipse at the same time commencing. At a slightly later instant, there will be two points, one in a higher and one in a lower latitude, at which the eclipse is just commencing at sunrise. All points at which the commencement of the eclipse occurs at sunrise may be connected by a curve. Similarly, points at which the eclipse is middle or just ending at sunrise may be connected by other curves. There will be two curves representing the northern and southern limits of the eclipse, at any point of which the eclipse ends at the instant of commencement. The curves joining points at which the eclipse begins, ends or is middle at sunrise meet on these lines. There will be similar curves joining points at which the eclipse begins, is middle or ends at sunset. The point of Last Contact at which the shadow leaves the earth will be on the line “Eclipse ends at sunset.” The lines representing the northern and southern limits are those swept out by the edges of the penumbra: the umbra itself traces out the narrow path of central

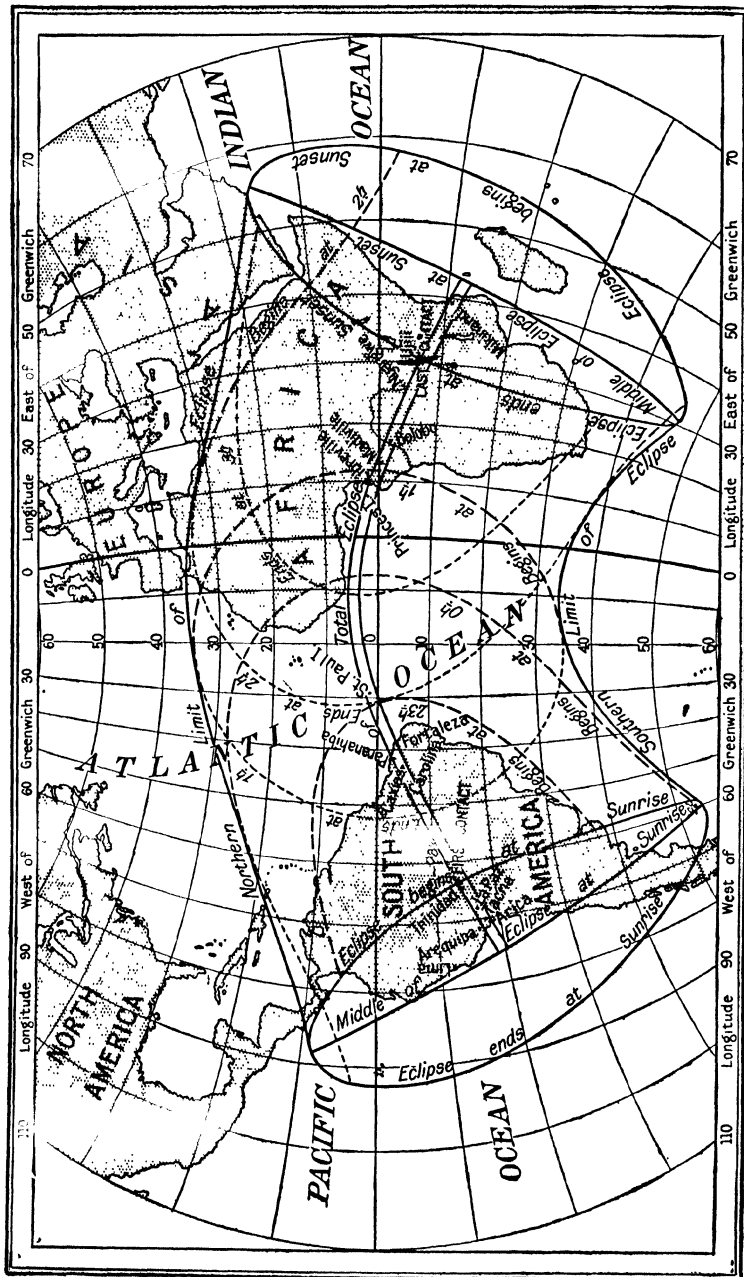

FIG. 52.—Total Eclipse of May, 28-29, 1919.

eclipse : this path must end on the lines at which the middle of the eclipse occurs at sunrise and sunset, since totality takes place at mid eclipse. It is also customary to give on the diagram curves joining the points at which the eclipse begins or ends at certain hours of Greenwich mean time : the approximate times of beginning and ending for any place within the eclipse region may then be obtained by interpolation.

84. Importance of Solar Eclipses.—Total solar eclipses are occurrences of considerable astronomical importance, which explains why astronomers undertake expeditions to great distances and frequently to places difficult of access in order to observe a phenomenon lasting at the most but a few minutes.

The solar corona can be observed only during totality, so that evidence as to its shape and constitution has had to be obtained from the relatively few eclipses which have been observed with modern methods : the total amount of time which has been available for the spectroscopic study of the corona cannot greatly exceed $\frac{1}{2}$ hour. The study of the constitution of the chromosphere, by means of the flash spectrum, can best be made at the instants of commencement and end of totality. The eclipse of 1851, July 28, was notable for the first attempt to photograph the corona, the method now always used to study its structure. The spectroscope was first used at an eclipse in 1868 and led to Lockyer and Janssen's discovery that the prominences might, with suitable arrangements, be seen at any time : previously they had only been observed during totality. The first observation of the green line in the spectrum of the corona, and the resultant discovery of coronium, occurred at the eclipse of 1869, August 7. The reversing layer was discovered at the eclipse of 1870, December 28, and the flash spectrum was observed at subsequent eclipses. At the eclipse of 1882, May 17, a bright comet was discovered on the photographs. At more recent eclipses the problems which arise have been further studied. The observations made at eclipses provide the best argument against the existence of a planet with an orbit nearer the Sun than that of Mercury. If such a planet existed, it is improbable that it would have

escaped observation at all the eclipses which have been well observed.

A total eclipse provides the only method for testing whether rays of light are deflected by a strong gravitational field, as predicted by the generalized relativity theory formulated by Einstein. The method is to photograph during totality the stars in the neighbourhood of the Sun and to compare their positions with the corresponding positions on photographs of the same region of the sky taken at night a few months previous or subsequent to the eclipse. If the light rays are deviated by the Sun, the stars will be apparently displaced away from the Sun's limb, since the star appears to be in the direction from which the ray reaches the observer. The displacement is small, only $1''.75$ for a star at the limb of the Sun and decreases outwards, inversely as the distance from the Sun's centre. The existence of such a displacement was tested at the eclipse of 1919, May 28-29, by two British expeditions and the prediction of Einstein was confirmed.

Solar eclipses which happened centuries ago are of great importance from the chronological point of view. If any event can be connected with the occurrence of a solar eclipse, the date of that event can be assigned with great accuracy and many disputed points in chronology have in this manner been settled. We have also seen that a comparison of ancient observations of total eclipses with present tables of the Moon enables us to determine the secular acceleration of the Moon.

85. Physical Phenomena associated with Solar Eclipses.—One of the phenomena which it was customary to observe at total solar eclipses some years ago is that of *shadow bands*. These consist of rapid alterations of light and shade at the time of commencement and ending of totality. If a white sheet is spread out, they appear as rapidly-moving, wave-like motions. They are probably due to undulations in the atmosphere causing a flickering of the light from the thin crescent and are not of great importance.

The phenomenon known as "Baily's beads" arises from the inequalities in the lunar surface: just as totality is approaching the last narrow crescent of light breaks up into

separate portions, giving the appearance of a string of beads. They were fully described by Baily, who observed them at the annular eclipse of 1836. The disappearance of the last bead is generally taken as the commencement of totality, and is also the moment for observing the flash spectrum: at this instant, also, the corona comes into view.

86. Occultations.—The Moon in its eastward motion amongst the stars frequently passes in front of—or occults—a fairly bright star. The circumstances of the occultation may be worked out for any point on the Earth's surface in a manner generally similar to that adopted in computing a solar eclipse; simplifications are introduced from the star having no motion, parallax or semi-diameter.

In the *Nautical Almanac* is given every year a list of the principal occultations visible at Greenwich, with the times of disappearance and reappearance and the points of the Moon's limb at which they take place. Data are also given for enabling the circumstances of the occultation to be calculated for any other point of the Earth's surface. As in the case of a solar eclipse, the phenomenon is visible only over a portion of a hemisphere and at different times at different places.

On account of the eastward motion of the Moon, the disappearance of the star always takes place at the eastern limb and the reappearance at the westward limb. Between new moon and full moon, the eastern limb is the dark limb; between full moon and new moon the western limb is dark. In the first case, the disappearance and in the second case, the reappearance therefore occurs at the dark limb. These phenomena occur instantaneously; indicating conclusively that the Moon is devoid of an atmosphere, for if it possessed an atmosphere, refraction would cause the star to fade away or to come into view gradually. The times of disappearance or reappearance at the dark limb can therefore be observed with great precision; at the bright limb, on the other hand, the star may be lost to view, if faint, before reaching the limb. Occultations provide a means of determining the Moon's position with a high degree of accuracy, provided the star which is occulted is one whose position has been well determined by meridian observations and that the latitude and

longitude of the place of observation are known. If, on the other hand, the Moon's position be determined from meridian observations and simultaneous observations of a given occultation are secured at two places on the Earth's surface, the difference of longitude of the two places can be determined. The method is accurate but suffers from the handicap that weather conditions frequently do not permit the observations to be secured at both places.

87. Transits of Mercury and Venus.—Another phenomenon which is akin to eclipses is the transit of a planet across the Sun's disc. For a transit to occur the planet must pass between the Earth and the Sun, and it is therefore only the two planets Mercury and Venus which can be observed to transit. The planet then appears as a black spot, projected upon the Sun's disc. The use of the transits of Venus for the determination of the Sun's distance has been described in § 64. The method has now been superseded by more accurate methods, but the phenomena are still of importance, as their occurrence affords the best opportunity for determining the angular diameters of the two planets and they also enable accurate determinations of the planets' positions to be secured.

The inclination of the orbit of Mercury to the ecliptic is about 7° , and a transit can only occur when the planet is very near one of its nodes at the time of inferior conjunction. The Earth passes through the nodes about May 7 and November 9, and the transits can therefore only occur near those dates. The possible transit limit corresponding to the mean distance of Mercury is $2^\circ 10'$, but the orbit of Mercury is not circular and in May it is nearer to the Earth than its mean distance and further away in November. This causes the May limit to be smaller than the November limit, so that transits are more frequent in November than in May.

Twenty-two synodic periods of Mercury are approximately equal to 7 years, 41 periods are more accurately equal to 13 years, and as a still better approximation, 145 periods are almost exactly equal to 46 years. It follows that a repetition of a transit may be looked for at intervals of 7, 13, or 46 years. At the May transit, the transit limit is so small that a repetition

after 7 years is not possible. The dates of the transits during the present century are :—

1907, November 12	
1914, November 6	1924, May 7
1927, November 8	
1940, November 12	
1953, November 13	1957, May 5
1960, November 6	1970, May 9
1973, November 9	
1986, November 12	
1999, November 14	

There is a very close approach on 1937, May 10, but no transit.

In the case of Venus, the inclination of the orbit is about $3\frac{1}{2}^{\circ}$, and the transit limit is only about 4° . The phenomena are of very rare occurrence ; 5 synodic periods of Venus are nearly equal to 8 years, and as a much better approximation, 152 synodic periods are nearly equal to 243 years. A transit may therefore recur after 8 years, but it is not possible for this to happen twice consecutively, and the next transit at the same node can only occur after 235 or 243 years. The dates of the transits are given in § 64.

CHAPTER VII

ASTRONOMICAL INSTRUMENTS

88. **THE** diverse requirements of astronomical observation and measurement necessitate the use of many different instruments. For detailed accounts of the construction and use of such instruments reference must be made to treatises dealing specially with this branch of the subject. It is only possible to give here a very brief description of some of the principal instruments used in the observatory. It is assumed that the student is acquainted with the elementary laws of optics, concerning the reflection and refraction of light and the method of formation of images by mirrors and lenses.

89. **Telescopes.**—Telescopes used for astronomical observations are of two kinds, in one of which the image is formed by a lens and in the other by a mirror. These are called respectively refracting and reflecting telescopes. The refracting telescope was probably invented in 1608 by Lippershey, a spectacle maker of Middleburg, but it was not until Galileo, a few years later, made improved models that it was applied to astronomical observation. These telescopes were constructed on the principle of the modern opera-glass, and were able to give only a very low magnification, and even then the images were ill-defined and not free from colour. The astronomical telescope with two convex lenses was first suggested by Kepler in 1611, but was not constructed until many years later. The reflecting telescope was invented by Newton about 1670, in order to avoid the chromatic effects obtained when a single lens is used for the object-glass in the refracting telescope. The achromatic lens for correcting for the colour effect was invented by Chester Moor Hall in 1733, but was first applied by Dollond in 1758.

The *Refracting Telescope* consists essentially in its simplest form of two convergent lenses (Fig. 53), one called the object-glass (O), with a long focal length F , and the other the eye-piece (E), with a much shorter focal length f . Since the objects to be viewed are always at a great distance, the rays from any point of the object which fall on the object-glass will be parallel. Thus, in Fig. 53, the rays S_0, S_1, S_2 , from a distant point in the direction OS_0 produced, are parallel and must come to a focus at a point s on S_0O produced, which is in the focal plane $F's$ of the object-glass: a real image of the distant point is therefore formed at s . This image is viewed through the eye-piece E . If E is so focussed that its focal plane coincides with that of the object-glass, then the bundle

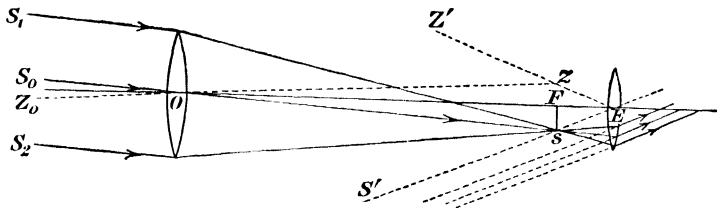

FIG. 53.—The Astronomical Refracting Telescope.

of rays from s must emerge from E as a parallel bundle and the final image is seen at infinity in the direction ES' . It will be noticed that the telescope is inverting: rays coming from a point above the axis OE emerge finally as though coming from a point below it. This is immaterial for astronomical purposes although inconvenient for terrestrial use.

If rays from another point Z_0 are considered, these are brought to a focus z by the object-glass and the final image is seen in the direction EZ' . Suppose the rays S_0O, Z_0O come from two points at the opposite ends of a diameter of the Moon: then S_0OZ_0 is a measure of the Moon's apparent diameter as seen by the naked eye. The image of the Moon produced by the telescope subtends, however, the larger angle sEz . The ratio of the apparent diameters of the image and object is a measure of the *magnifying power* of the telescope. But angle sEz : angle S_0OZ_0 = angle sEz : angle sOz = $1/f$: $1/F$ = F/f . The magnifying power of the telescope is

therefore the ratio of the focal lengths of the object-glass and eye-piece. If the object-glass has a focal length of 20 ft. and the eye-piece of $\frac{1}{2}$ in., the magnification will be 480; if the eye-piece has a focal length of 1 in., the magnification will be 240. It might be thought that since any desired magnification can be obtained merely by using an eye-piece of sufficient power, a large object-glass is not necessary: but a large aperture is required for other purposes, viz. for securing sufficient brightness of image and resolving power.

90. Brightness of Image.—The objects to be viewed may be either extended bright surfaces, such as the Moon, or bright points of light, such as stars, which are too far distant to give an image showing a disc. In the case of a star, all the light falling on the object-glass (except for a certain loss by absorption in the object-glass and reflection between its surfaces) is collected into a point image: the brightness of the image is therefore proportional merely to the area of the object-glass or, as is more usually stated, to the square of its aperture (A^2). Thus a 10-inch object-glass will give an image twice as bright as a 7-inch. In order to obtain faint stars, a large aperture is therefore essential.

In the case of an extended object, a small area of the object gives rise to an image of finite area in the focal plane of the object-glass. For a given aperture, the area of this image is proportional to the square of the focal length of the object-glass (since any dimension of the image is proportional to F). The resultant brightness of the image is therefore proportional to A^2/F^2 , this quantity being proportional to the quantity of light falling on the object-glass and inversely proportional to the image area over which the light is spread. The important consideration is therefore to have a large ratio of aperture to focal length: a telescope in which $A/F = 1 : 5$ will, for instance, give an image of four times the brightness of that given by one in which $A/F = 1 : 10$. It can be shown, however, that by no optical arrangement whatsoever can the brightness of the image of an extended object be increased beyond what it appears to the naked eye.

91. Resolving Power of a Telescope.—We have hitherto

supposed that the image of a luminous point formed by the telescope will also be a point. This result is arrived at on the purely geometrical theory of optics which supposes that light travels in straight lines ; light is, however, a wave motion of very short wave-length, and a slight bending of the waves occurs at the edges of an obstacle. When the nature of the image of a luminous point produced by a circular aperture is investigated by the accurate physical method, it is found to consist of a central disc, brightest in the centre and fading off gradually towards the edge, which is surrounded by a series of bright diffraction rings, the brightness of successive rings decreasing rapidly so that generally only the one of

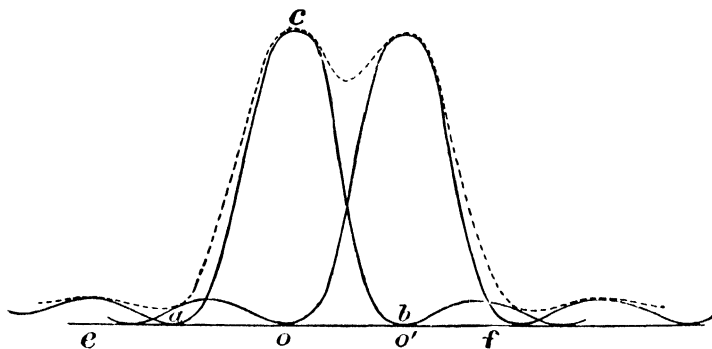

FIG. 54.—To illustrate Resolving Power.

smallest radius is seen. The diameter of the dark ring between the central nucleus and the first bright ring is $1.22 \lambda F/a$, λ being the mean wave-length of the light, a the aperture of the object-glass and F its focal length. The larger the aperture for a given focal length, the smaller is the diameter of the ring.

Now suppose that two distant bright points, subtending a small angle θ are viewed. If θ is sufficiently small, the diffraction rings surrounding the two nuclei may be superposed to such an extent that the separate nuclei may not be visible. In such a case, the telescope fails to resolve the object into its two components. The limiting angle θ which can be resolved is determined as follows : in Fig. 54 are given the intensity curves of the images of the two points : o is the centre of the nucleus of one image, oc the intensity there,

a, b the points in the plane of the paper at which the intensity vanishes (first dark ring); e, f the points in the first bright ring. The other point will give a similar intensity curve with centre at o' . The resultant luminosity is obtained by adding the ordinates of the two curves. If o' coincides with b , i.e. the centre of one image coincides with the first minimum of the other, the final intensity curve will have two maxima (at o and o') with a perceptible dip between: the two nuclei will therefore just be seen and the object will be resolved. The linear distance apart in the focal plane of the object-glass of o and o' will therefore be $1.22 \lambda F/a$, corresponding to an angular separation $\theta = 1.22 \lambda/a$. If the two luminous points subtend a lesser angle than this, the image formed by the telescope will be indistinguishable to the eye from that of a single point. If a is expressed in inches, this formula corresponds—for a mean wave-length of 5,500 Angstrom units—to an angular separation of $5.4''/a$. For example, if the components of a double star subtend an angle of $1''$, a telescope with an aperture of at least 5 inches will be necessary to reveal that the star is double. With a smaller telescope, no increase whatever in magnifying power could show this. Large apertures are necessary, therefore, not only for viewing faint objects, but also for revealing fine detail or for separating close double stars: or, as this result is generally stated, the *resolving power* of a telescope is proportional to the aperture.

92. Spherical and Chromatic Aberration.—In the pre-

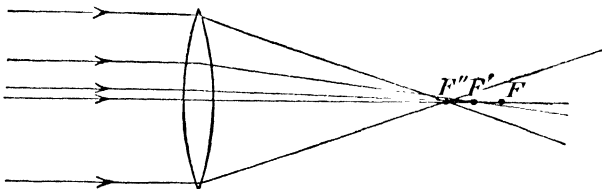

FIG. 55.—Spherical Aberration.

ceding paragraphs it has been tacitly supposed that the object-glass is perfect, i.e. that all parts of the object-glass bring the light to a focus at the same point and that all colours are focussed together. With a single lens, neither of these

conditions holds. In the case of a single convergent lens upon which parallel light is falling, the rays passing through the outer zones of the lens are focussed nearer to the lens than those passing through the central portion (Fig. 55): in the case of a single divergent lens, the converse holds, the focus of the central portion being nearest to the lens. This defect is known as *spherical aberration*. For a given focal length, it can be reduced by a suitable choice of the radii of curvature of the lens surfaces, and by using a compound lens the curvatures can be adjusted so that two chosen zones bring the light to a common focus and so that the difference in focus of any other zones is very small.

Chromatic aberration arises from the index of refraction of glass, in common with other substances, being different for different colours. A single convergent lens will bring the blue rays to a focus nearer the lens than the red rays (Fig. 56). The difference in the refractive powers for any two chosen colours varies with the type of glass and it

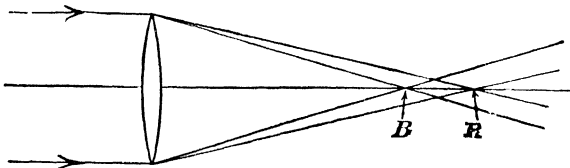

FIG. 56.—Chromatic Aberration.

is therefore possible by combining two types of glass to make an achromatic lens, i.e. a lens in which any two chosen colours are brought to a common focus. By suitable choice of the curvatures of the two surfaces, it is possible at the same time to correct the spherical aberration also. A compound lens is usually made of a convex lens of crown glass, combined with a concave lens of flint glass.

The manner in which the chromatic aberration is corrected depends upon whether the telescope is to be used for visual or photographic observation. In the latter case, it must be corrected for the rays which have the most actinic effect, i.e. the blue and violet; in the former, it must be corrected for the yellow and green rays.

If the lens is required to have a large flat field, it should

be built up of three single lenses, as the field of an ordinary doublet lens is somewhat curved. In fact, the more stringent the conditions with which the lens is required to comply, the more complicated does its design become. Reference should be made to treatises on geometrical optics for detailed accounts of the various defects of lens systems and of the methods of correcting them.

93. The Reflecting Telescope.—The dispersion of light was discovered by Newton, who came to the erroneous conclusion that the dispersive power of different types of glass was the same. If this were so, it would not be possible to correct the chromatic aberration of a lens without at the same time neutralizing its power to bring parallel light to a focus. In order to avoid chromatic effects, Newton therefore invented the reflecting telescope. In this type of telescope, the light falls on to a concave mirror which converges it to a focus and so performs the same function as the object glass of a refracting telescope. There are several types of reflecting telescope, the principal being (i) the Newtonian, (ii) the Gregorian, and (iii) the Cassegrain.

In the Newtonian telescope, the convergent beam of light reflected from the mirror is intercepted, just before reaching its focus, by a small plane reflecting mirror, situated on the axis of the telescope and inclined to it at an angle of 45° . This mirror reflects the light to a focus at the side of the tube where the eye-piece is placed. The Gregorian and Cassegrain types are very similar: the large mirror is pierced at its centre by a hole and the light coming from it is reflected through the hole, in the Gregorian form, by a small concave mirror a little outside the focus, on the axis and perpendicular to it, and in the Cassegrain form by a small convex mirror, placed a little inside the focus. The Cassegrain telescope has the advantage of giving a flatter field than the Gregorian, which is now but little used. Instead of piercing a hole through the large mirror, a small plane mirror may be placed in front of the large mirror to reflect the light towards the side of the tube.

With the same large mirror, it is possible by using different small mirrors, to convert the same telescope into any one of

these types, giving different equivalent focal lengths (Fig. 57). It is thus possible to use that type of reflector which is best suited to the observations required to be made.

The figure shows the different ways in which the 60-inch reflector of the Mount Wilson Observatory is used. The focal length of the mirror is 25 feet, and when used as a Newtonian

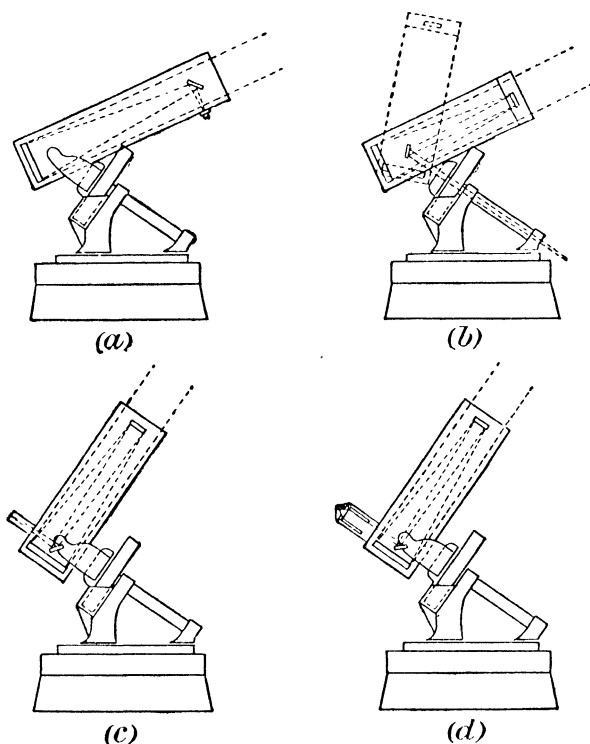

FIG. 57.—Various Methods of using a Reflecting Telescope to give different equivalent Focal Lengths.

reflector, without secondary magnification, the focal length of the telescope is also 25 feet (Fig. 57[a]). In order to use it as a Cassegrain reflector, the upper section of the telescope tube carrying the plane mirror is removed and replaced by a shorter section with a convex (hyperboloidal) mirror. This returns the rays towards the centre of the large mirror, at the same time reducing their convergence and so increasing the equivalent focal length. A small plane mirror is supported at the

point of intersection of the polar and declination axes and is so inclined that it reflects the light down the hollow polar axis, where it is brought to a focus on the slit of a powerful spectroscope (Fig. 57[*b*]). The mounting of the plane mirror is geared so that as the telescope is rotated about the declination axis the light is always reflected down the polar axis. This method of using the telescope enables a larger spectroscope to be used than could conveniently be attached to the telescope. The equivalent focal length is 150 feet. Fig. 57(*c*) shows the telescope used as a Cassegrain reflector, with an equivalent focal length of 100 feet, the light in this case being brought to a focus at the side of the tube: in this form the instrument is used for large-scale photographs of Moon, planets, nebulae, etc. Fig. 57(*d*) shows a similar Cassegrain combination with different focal length (80 feet), used in conjunction with a spectroscope.

94. Relative Advantages of Reflectors and Refractors.

—Each type of instrument has some advantages not possessed by the other and they are really complementary to one another in their uses. For some types of observation, the reflector, and for others, the refractor is preferable.

In one respect, the reflector has a distinct advantage. The construction of a large object-glass is much more difficult and expensive than that of a mirror of the same aperture. It is essential that the component lenses should be absolutely homogeneous throughout and free from striations and other defects. The casting and annealing of a large disc of optical glass which will meet these requirements is a matter of the utmost difficulty. But granting that the discs have been successfully obtained, they have then to be ground and polished to certain curvatures, obtained by calculation and so chosen as to reduce the various aberrations. Finally, local polishing by hand must be resorted to in order to obtain the best results. The largest object-glass which has been constructed is the 40-inch of the Yerkes Observatory. The disc of glass for a reflector need only be reasonably homogeneous and well annealed in order to avoid irregular distortion with change of temperature. There remains then but one surface to be optically worked. To cast a disc sufficiently large for

a 6-foot or 8-foot mirror is indeed a difficult undertaking; thus the original disc from which the Mount Wilson 100-inch mirror was constructed weighed $4\frac{1}{2}$ tons. But the combined difficulties are much less than in the case of the refractor. It must further be remembered that even if it were possible to construct very large objectives, their weight would be sufficient to distort them to such an extent that they would be optically useless: a large mirror, on the other hand, can be so supported from behind that its weight is counteracted. The employment of a reflector therefore enables a larger aperture to be used. Another advantage of the reflector is that a larger angular aperture can be secured than with a refractor. The angular aperture is measured by the ratio of linear aperture to focal length, and as we have seen in § 90, a large angular aperture is necessary for securing a bright image of a faint extended object. In the case of a refractor, there is difficulty in correcting the spherical aberration if the aperture ratio is greater than about 1 in 12, whereas with a reflector a much greater angular aperture (up to 1 in 4) can without difficulty be secured. For all purposes, therefore, for which very great light-gathering power is essential, a large reflecting telescope must be used.

The reflector has a further advantage: it is perfectly achromatic and if, as is customary, the surface of the mirror is worked into the form of a parabola, light parallel to the axis falling on every part of the surface will be brought to the same focus, so that there is no spherical aberration for such rays except that introduced by the reflection at the small mirror, which can be reduced if the mirror is made hyperboloidal.

Against these advantages of the reflector may be placed the following advantages of the refractor. Comparing a reflector with a refractor of the same aperture, the loss of light by absorption in the object-glass is less than that by reflection at the mirror, except for very large apertures. Hale has estimated that for apertures up to about 32 inches, refractors surpass reflectors in light grasp for both visual and photographic rays. Between apertures of 32 inches and 50 inches the refractor gives brighter visual images, but the reflector is superior for photographic purposes. For larger

apertures, the light grasp of the reflector becomes superior for both visual and photographic rays. The refractor does not deteriorate with age, whilst the reflector needs resilvering at frequent intervals, owing to the tarnishing of the silvered surface. Moreover, the focus of a refractor is less liable to change with changes of temperature than is that of a reflector. This is of importance in photographic work of precision in which very small displacements of images require to be measured. With a refractor it is also possible to obtain a larger flat field of good definition than with a reflector.

95. Eye-Pieces.—A simple convex lens gives bad distortions of the image and introduces a lot of colour unless the object is exactly in the centre of its field. Eye-pieces are therefore usually composed of two or more lenses, by which means the aberrations may be reduced and good images

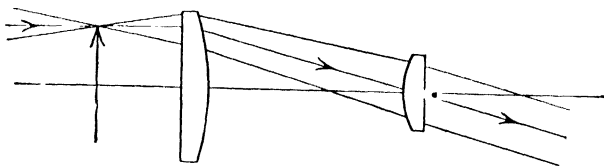

FIG. 58.—The Ramsden Eye-piece.

obtained over a much larger field. Two of the most common forms of eye-piece are the Ramsden and the Huyghenian. Each of these eye-pieces is composed of two plano-convex lenses made of the same sort of glass; the one which faces the incident light is called the field-lens, the other the eye-lens. In the Ramsden eyepiece (Fig. 58), the two curved surfaces face towards one another, and in order to secure the greatest freedom from colour the focal length of the eye-lens should be equal to that of the field-lens and to the distance apart of the two lenses, though these distances are varied somewhat in practice. This eye-piece gives a very flat field and is approximately achromatic for parallel light. It has the advantage that the principal focus of the combination is outside the field-lens, so that it is possible to place a system of spider-webs in the focal plane of the object-glass of the telescope, which can be viewed with the image through the

eye-piece. This is necessary for many purposes in astronomy, and an eye-piece which enables this to be done is called a positive eye-piece.

The Huyghenian eye-piece (Fig. 59) consists of two plano-convex lenses, the focal length of the eye-lens being one-half

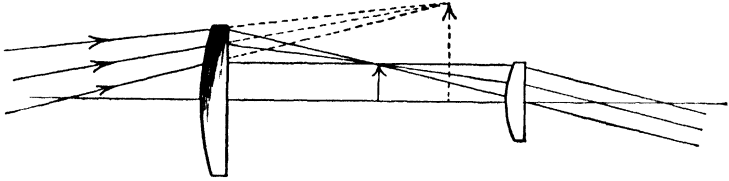

FIG. 59.—The Huyghenian Eye-piece.

that of the field-lens and their distance apart one-half the sum of the focal lengths. The curved surfaces of the field and eye lenses face the incident light. Since the principal focus of the combination is between the two lenses, it follows that when focussed on the image formed by the object-glass, the rays converging to form this image are intercepted before they have come to their focus, and a (virtual) image is formed between the lenses of the eye-piece. Such an eye-piece is called a *negative* eye-piece and cannot be used for any purpose in which it is necessary at the same time to focus on a graticule system.

These eye-pieces are not absolutely achromatic. For purposes not requiring a large field of view a simple compound lens may frequently be used with advantage. To obtain the most satisfactory results, the colour correction of the object-glass should be decided in conjunction with the eye-piece intended to be used most frequently with the telescope, and the combination made as nearly as possible achromatic.

It is usual to provide any instrument with several eye-pieces of different focal lengths, so enabling the magnification which is most suitable for any particular observation to be used. It must be emphasized, however, that increase of magnification for an object-glass of given aperture does not entail any increase in resolving power and since an increase in magnification also increases the disturbances arising from atmospheric irregularities, there is a limit—depending upon the definition

at the time of observation—beyond which it is inadvisable to increase the magnification.

96. The Transit Instrument.—This instrument, which is used for the determination of sidereal time, is necessarily one of the fundamental instruments of an observatory. The observations consist in determining the times of the transits of stars across the meridian. It is known (§ 6) that when a star is on the meridian, the sidereal time is equal to its right ascension ; if, then, the clock time of the transit is determined, the error of the clock can be found, provided that the right ascension of the star is known.

The instrument consists essentially of a refracting telescope, as illustrated in Fig 60, which is supported at the ends of an axis, perpendicular to the tube, by two trunnions moving in Y-bearings. The axis is horizontal and points east and west, so that as the telescope swings on the axis it moves in the meridian. It is important that the axis should be stiff, the telescope tube sufficiently strong to prevent flexure, and the pivots accurately cylindrical, equal and coaxial. In the focal plane of the object-glass is placed a framework carrying a number of vertical spider-lines (or “wires” as they are usually called), and a single horizontal wire across the centre of the field. A graduated circle is fixed to the axis and rotates with it, enabling the instrument to be set on a star of any required declination.

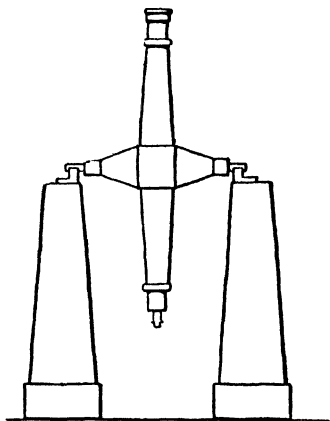

FIG. 60.—Schematic Transit Instrument.

The observation of a transit consists in the determination of the times that the star image passes across each vertical wire ; this may be done by the “eye-and-ear” method, i.e. the observer watches the star and listens to the beats of the clock, interpolating the times of transit across each wire to the nearest tenth of a second. It is now customary, however,

and more accurate to record these times electrically, with the aid of a chronograph. For this purpose a hand tapper may be used, but the most modern method is to use a self-recording micrometer. This carries a second frame on which is mounted a single vertical wire; this frame can be traversed across the field of view, immediately behind the frame previously referred to. The observer causes the travelling wire to move at such a rate that the star image is continuously bisected by it and at regular intervals during the transit a record is automatically made on the chronograph. By this means, personal errors which were inevitable when the hand tapper was used and which arose from systematic differences between the methods of observing of different observers, are almost entirely eliminated.

The advantage of having a number of taps recorded on the chronograph is that the accidental error of observation is greatly reduced. The intervals between the wires must be determined by special observations, and the time of passage across each wire can then be reduced to a time of passage across the central wire. Provided that the axis of the instrument is exactly horizontal and points due east and west and that the central wire is exactly in the meridian, the time of transit is equal to the star's right ascension. In practice none of these conditions hold, and the amounts of the three errors, level error (axis of the instrument not horizontal), azimuth error (axis of the instrument not east and west), and collimation error (the optical axis or the line joining centre of object-glass with middle wire not perpendicular to the axis of rotation), must be accurately determined. If the instrument has been carefully set up in the first place and if its support is stable, these errors will always be small though somewhat variable, and their exact amount must be determined daily by suitable observations. A 3-inch transit instrument is shown in Fig. 61.

97. Adjustments of Transit Instrument.—*Collimation.*
—Small transit instruments can usually be reversed, i.e. the axis turned through 180° so that the east and west pivots change places. If a distant fixed object is available on which the instrument can be pointed, the position of this object relative to the centre wire is observed and the telescope is

then reversed on its axes and again pointed to the same object. If the centre wire points in the same direction relatively to the distant mark as it did before reversal, there is no collimation error: if not, the error is given by half the angular distance between the two pointings. If a distant fixed mark

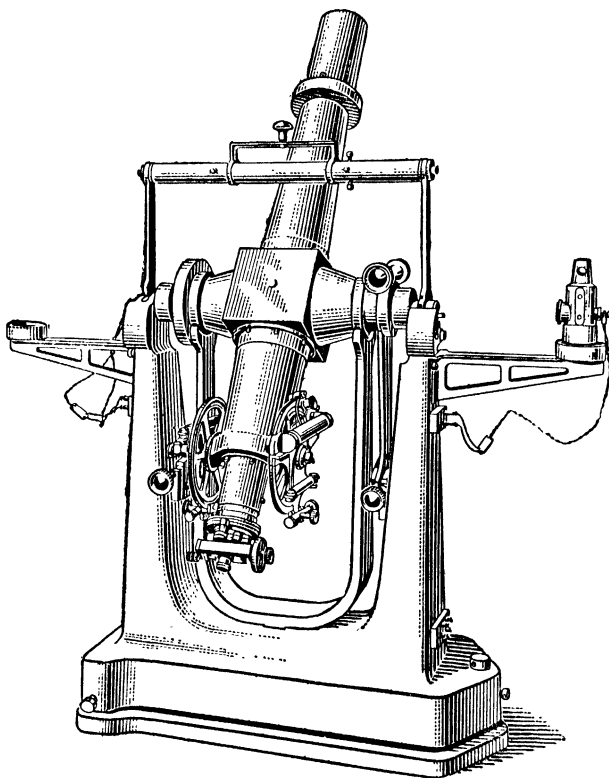

FIG. 61.—Three-inch Transit Instrument.

is not available, a collimating telescope can be used. This is an auxiliary telescope, in the focus of which is placed two cross wires. The telescope is firmly mounted in the meridian with its object-glass towards the transit instrument, so that when the latter is horizontal, it is possible to look straight through it into the collimator. The cross wires in the focus of the latter then serve as a suitable infinitely distant object, which can be used as before for determining the collimation.

If the telescope is not reversible on its axis, two collimating telescopes must be used, one placed to the north and the other to the south of the transit instrument. One collimator must first be adjusted to the other and the telescope then set on each alternately in order to determine the collimation error.

Level.—In the case of small instruments, the error of level is usually determined by means of a sensitive graduated spirit level, called a striding level, which is so constructed that, when the telescope is horizontal, it can rest on the two pivots. The position of each end of the bubble is read, and the level is then reversed. The half-difference between the means of the readings given by the two ends of the bubble determines the amount by which the axis of one pivot is higher than that

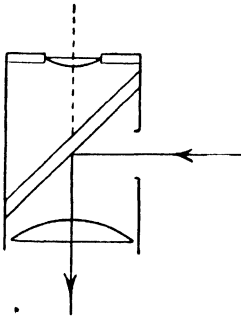

FIG. 62.—The Bohnenberger Eye-piece.

of the other, provided that the pivots are of the same size and that the angular tilt required to displace the bubble of the level through one division is known. A striding level cannot be used with a large instrument, and a different method must then be adopted. Such instruments are provided, in addition to the fixed framework carrying the wires, with a second frame carrying a single wire, which can be moved by an accurate micrometer screw. The telescope is set in a vertical position with the object-glass downwards and a bath of mercury is placed beneath it. Using a Bohnenberger eye-piece, i.e. a common Ramsden eye-piece with a hole in one side and a thin glass plate inserted at an angle of 45° (Fig. 62), the light from a lamp at the side of the instrument is thrown down the tube and the image of the movable wire formed by reflection from the mercury surface is observed. A movement of the wire produces an equal movement of the image in the opposite direction. The micrometer screw is turned until the wire and its image coincide. The plane passing through the wire and the centre of the object-glass must then be exactly perpendicular to the mercury surface and therefore vertical. If this direction coincides with that which is perpendicular to the axis of the instrument, as determined from the observation

of collimation, the axis is horizontal and there is no level error. If, on the other hand, the two directions do not coincide, their difference determines the amount of the error.

Azimuth Error.—The amount of this error can only be determined from astronomical observations. It is necessary first to reduce the level error to a small amount and to know approximately the error of the clock. A star near the pole is then observed: when the clock time (corrected for error) is equal to the R.A. of the star, it is known that the star is on the meridian, and the position relative to the telescope axis of a line which is due north and south is thus determined, enabling the error of azimuth to be deduced. The actual procedure is somewhat more involved, although the principle is essentially as described. It involves the observation of stars of different declinations by which means the error of azimuth, which affects stars of low altitude to

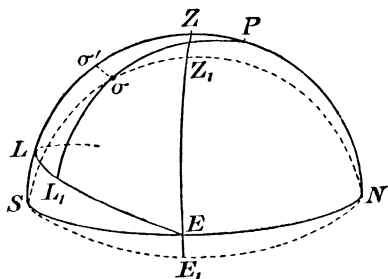

FIG. 63.—Level Error of Transit Instrument.

the greatest extent, can be separated from level error which affects predominantly stars of high altitude.

It is not possible to adjust the instrument so that these errors are exactly eliminated, but with a stable instrument, initially well adjusted, they will always remain small in amount. Their magnitudes must be determined in the way just described and a correction applied to the observed time of transit of a star to obtain the true time of transit across the meridian. Provided that the errors are small, their effects can be treated as independent of one another and the required correction can be easily obtained.

Consider first the error of level. We will assume that the axis is perpendicular to the N.S., but that instead of being horizontal, it is inclined to the horizon at a small angle b , the east end being the lower. It therefore points to a point E_1 on the celestial sphere (Fig. 63), which is on the prime vertical but below E by the amount $EE_1 = b$. It is then apparent that

when the instrument is rotated upon its axis, the axis of the telescope—the collimation error being neglected for the present—instead of moving in the meridian SZN , moves in the great circle SZ_1N , whose pole is E_1 . If a star σ is on this circle,

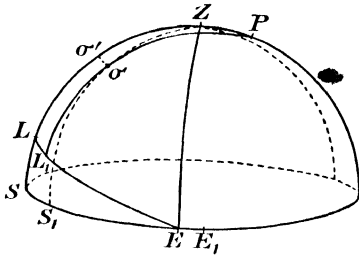

FIG. 64.—Azimuth Error of Transit Instrument.

it will appear to be on the meridian, although it actually has an easterly hour-angle LL_1 , L_1 being the point in which the hour circle through σ meets the equator. If σ' is the point at which σ crosses the true meridian, $L\sigma' = \delta$, the declination of the star, and $LZ = PN = \phi$, the latitude. Hence $\sigma'Z = \phi - \delta$

and $\sigma\sigma' = ZZ_1 \cos \sigma'Z = b \cos (\phi - \delta)$. Also $\sigma\sigma' = LL_1 \cos \delta$ and so the hour-angle $LL_1 = b \cos (\phi - \delta) \sec \delta$, and this must be added to the observed time of transit to obtain the true time of meridian transit.

Considering next the effect of a slight error in azimuth of amount k , the level and collimation errors now being neglected. Suppose the axis is inclined by the amount k to the north of east, and so points to a point E_1 on the horizon such that $EE_1 = k$ (Fig. 64). Then as the instrument is rotated, the axis of the telescope moves in a great circle which passes through the zenith and through a point S_1 on the horizon such that $SS_1 = k$. A star σ therefore appears to be on the meridian when its easterly hour-angle is $\sigma P\sigma'$. Then, reasoning as before, $\sigma\sigma' = SS_1 \sin \sigma'Z = k \sin (\phi - \delta)$ and the hour-angle is $k \sin (\phi - \delta) \sec \delta$, which must also be added to the observed time of transit to obtain the true time.

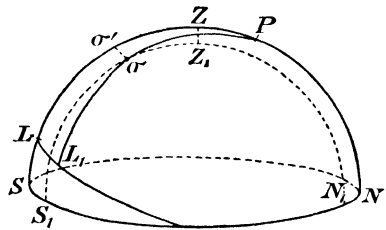

FIG. 65.—Collimation Error of Transit Instrument.

Finally, the error in collimation must be considered. Suppose that the error in perpendicularity of the axis of the telescope and the axis of the instrument is c , so that the end of the axis

describes a small circle $S_1Z_1N_1$ (Fig. 65) when the instrument is rotated, where $SS_1 = NN_1 = c$ and N_1, S_1 are east of the meridian, it being now assumed that level and azimuth errors are zero. Then with the same notation as before, $\sigma\sigma' = c$ also and $LL_1 = c \sec \delta$, which must also be added to the observed time of transit.

If all three errors are present, the resulting error in the observed time of transit can be represented by

$$t = b \cos (\phi - \delta) \sec \delta + k \sin (\phi - \delta) \sec \delta + c \sec \delta.$$

If b, k, c are expressed in time, t will be given in time also. Usually, b, k are expressed in angle and c in time. In that case, b, k must first be converted into time for substitution in the above formula.

This result is often expressed in the form—

$$t = m + n \tan \delta + c \sec \delta,$$

where $m = b \cos \phi + k \sin \phi, n = b \sin \phi - k \cos \phi$.

In this form the effect of the declination of the star on the time of transit is more readily seen. As δ approaches $\pm 90^\circ$, i.e. for stars near the poles, the error in the time of transit for given instrumental errors increases rapidly.

98. **The Meridian or Transit Circle.**—The simple transit instrument is used only for the observation of times of transits of stars. The meridian circle is used to determine in addition the declinations or north polar distances of objects. For this purpose, a large and accurately graduated circle is attached to and concentric with the axis of the instrument and revolves with the telescope. When the telescope is set on any object the position of the circle may be read by means of four or six reading microscopes, fixed to the pier supporting the axis. Each microscope carries in its focal plane a pair of parallel spider-lines which can be moved by a micrometer screw, with a graduated head. The reading of each micrometer corresponding to the position in which the parallel wires are equidistant on either side of the nearest graduation of the circle is read. Usually one revolution of each micrometer screw corresponds to $1'$ of arc and the micrometer head is divided into 60 parts, each being then equal to $1''$. By estimation, the micrometers can be read to a tenth second. The main circle is usually graduated every $5'$ and an index microscope enables the

position of the circle to be read to the nearest 5': the reading microscopes then give the extra minutes and seconds. The purpose of having several microscopes is to obtain increased accuracy and also to eliminate errors due to slightly incorrect centring of the circle.

In the meridian circle, the framework carrying the horizontal wire and the system of vertical wires is movable in the meridian at right angles to the telescope axis by a micrometer screw with graduated head. When the star enters the field of view, the telescope is clamped in such a position that the star is near the horizontal wire. By means of the micrometer screw, the horizontal wire is raised or lowered so that it bisects the star when it passes across the central vertical wire. From the readings of this micrometer and the reading microscopes, the exact circle reading for the particular star is obtained. To determine the declination or altitude of the star, the reading of the circle corresponding to a definite position of the telescope must be found: thus, if a close circumpolar star is observed on the meridian above pole and 12 hours later below pole, the mean of the two readings, corrected for refraction and instrumental errors, gives the reading corresponding to declination 90° , enabling the declination corresponding to any other reading to be obtained.

It is more usual to determine the circle reading corresponding to the position in which the telescope is exactly vertical: for this purpose, a mercury bath and a Bohnenberger eye-piece are used, just as in determining level, but the reading of the declination micrometer is obtained corresponding to the position in which the horizontal wire and its image coincide. The microscopes are also read in this position so that the circle reading corresponding to the nadir point is obtained.

99. The Altazimuth.—With the meridian circle, only observations in the meridian are possible. Although these observations are the simplest and most accurate, there are some purposes for which it is necessary to secure extra-meridian observations: e.g. just after or just before new moon. When the Moon is near the Sun, it is not possible to observe it at meridian transit and observations for its position must be secured just after sunset or just before sunrise. For this purpose, an

altazimuth (i.e. altitude and azimuth) instrument is employed. This type of instrument is essentially a transit circle which can be rotated about a vertical axis into any desired azimuth. It is therefore in principle similar to, though much larger than, a theodolite. The azimuth of the instrument is determined from stellar observations, the azimuth circle being used only to set the instrument with sufficient accuracy into any desired azimuth. The errors of adjustment are determined exactly as in the case of the transit instrument.

100. **The Chronograph.**—In modern methods of observation with the meridian circle or altazimuth, the times of transit of an object across the vertical wires are recorded automatically: for this purpose an instrument called a chronograph is employed. The most common type of chronograph, such as that shown in Fig. 66 (which

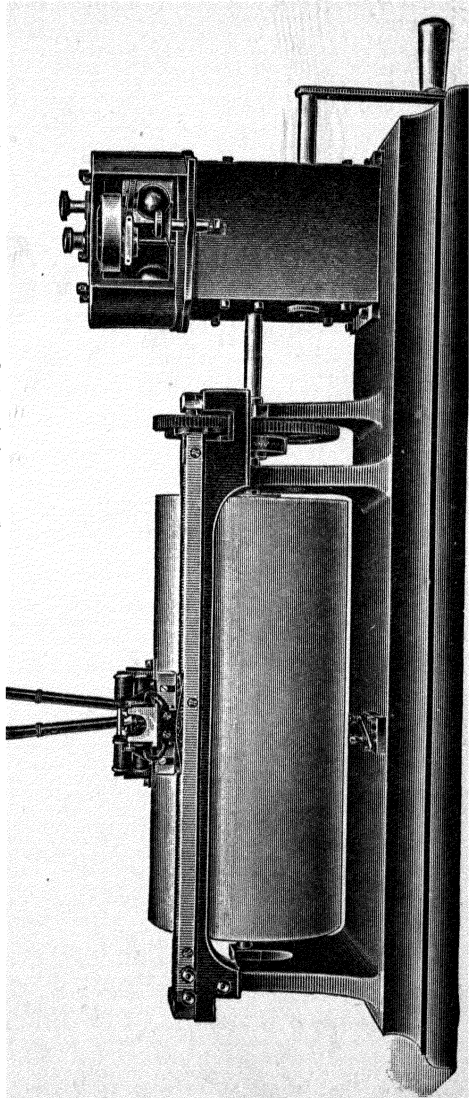

FIG. 66.—Chronograph

is made by Messrs. T. Cooke & Sons, of York), consists of a cylindrical barrel, several inches in diameter and about 15

inches long, around which is wrapped a sheet of paper. The barrel is rotated by clockwork controlled by a governor, to secure a uniform rate, usually one revolution in two minutes. A pen carried on the armature of a small electromagnet marks the paper, and as the barrel rotates, this pen is traversed slowly along by means of a screw so that it describes a continuous helical trace on the paper. Every two seconds (or sometimes every second) a momentary current from the sidereal clock passes through the electromagnet, attracting the armature and causing the pen to give a slight kick and therefore a break in the trace, as illustrated in Fig. 67. A longer break every 60 seconds denotes the commencement of a minute.

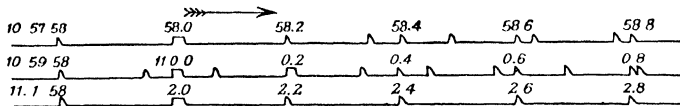

FIG. 67.—Portion of Trace given by Recording Chronograph.

When the observer at the instrument makes a tap with his hand tapper at the instant a star passes one of the vertical wires, a current is again sent through the electromagnet, causing a corresponding mark on the record. The positions of these marks and hence the corresponding times can be read off the trace whenever convenient after the evening's observations have been completed. Fig. 67 shows a portion of a chronograph trace, on which the times of the clock taps have been indicated. The observer's taps, corresponding to the transits of two stars, are shown in the first two lines. The intervals between the taps in the first line is greater than in the second, showing that the first star had the higher declination. At 11 h. 0 m. 2 s., one of the taps coincides with a clock tap, causing a wide break on the record similar to the wider breaks at the commencement of each minute.

101. Clocks.—Without an accurate means of measuring time, the modern progress in observational astronomy would not have been possible. The great improvement on the old methods followed the application by Huyghens in 1657 of the

pendulum as a regulator of the clock mechanism. There is no necessity here to enter into the details of clock construction, for which information reference should be made to a treatise on horology. The astronomical clock does not differ in its essential details from an ordinary clock, but it is necessary that it should be constructed with very great care, in order that the clock may not behave erratically, so that if observations of time are not possible for two or three nights, the time given by the clock (after correction for its rate) may be nearly correct. The clock must therefore have an accurate escapement and must be compensated for changes of temperature and of barometric pressure.

If the pendulum were a steel rod, beating seconds, its daily rate would change by one-third of a second for each degree (Centigrade) change in temperature. This is the direct consequence of the change in the length of pendulum as the temperature changes. To correct for this, various compensation devices may be used. Thus Graham's mercurial pendulum is fitted at the bottom with a vessel containing mercury, the amount of which is adjusted so that as the temperature rises, the upward expansion of the mercury is exactly sufficient to compensate the downward expansion of the steel rod. Another common type is based upon the gridiron pendulum of Harrison, the inventor of the chronometer: it consists of rods of zinc and steel, the upward and downward expansion of which just compensate one another. These devices are liable to introduce errors through a lag in their adjustment when the temperature changes rapidly. The best clocks are therefore now provided with pendulums of invar, an alloy discovered by Guillaume which, as its name suggests, does not change its length with change of temperature.

Change in barometric pressure causes a change in the resistance of the air to the swing of the pendulum and therefore alters the time of swing. A rise of one inch in the barometric height causes an ordinary pendulum clock to lose about one-third of a second daily. The simplest method of compensating is to enclose the clock in an air-tight, partially exhausted case. This is the method adopted by Riefler, of Munich. Alternatively, various types of compensation have been devised.

If a clock is required for use with a chronograph, a toothed wheel on the axis of the escapement wheel is usually arranged to touch a light spring at alternate seconds, so completing an electric circuit and sending a momentary current through the coils of the electromagnet to the armature of which the recording pen is attached.

The *error* of a clock is the amount which must be added to the time given by the clock in order to obtain the true time. The *rate* of a clock is the amount of its gain or loss in a day ; if the clock is losing, the rate is taken as positive and so increases the error when the clock is slow and decreases it when it is fast : if the clock is gaining, the rate is negative. A steady rate can be determined and allowed for and is therefore immaterial, although it is convenient that the rate should be small. The test of the quality of a clock is the absence of variations in its rate arising from changes of temperature, pressure, or accidental causes.

102. Equatorial Telescopes.—The telescopes which have been described in the preceding sections are required only for the determination of time or of the positions of celestial objects. They are used merely as pointers and, on account of the rotation of the Earth, the object under observation remains in the field of view for only relatively few seconds. For many purposes, it is desirable to retain the object stationary in the field of view. For such purposes, an equatorial telescope is used. This type of telescope has an axis, supported at its two ends in bearings so that it is free to rotate. The axis points towards the pole of the heavens and is therefore parallel to the axis of the Earth. Rigidly fixed at right angles to the polar axis, is a second axis called the declination axis, and at the end of this axis the telescope is supported with its axis at right angles to the declination axis. The telescope can be rotated about the declination axis. The polar axis is caused to rotate slowly by a clock-work mechanism, at such a rate that the rotation of the Earth is exactly counteracted. Owing to the great distance of all celestial objects, the combination of the equal and opposite rotations about parallel axes results in an object remaining stationary in the field of view of the telescope.

The polar axis carries a circle, graduated in hours and minutes, called the hour-circle or right-ascension circle.

The vernier of this circle reads 0 h. when the declination axis is horizontal, the telescope being then in the meridian. When the telescope is directed to any star, the hour-angle of the star can be at once read off, and the right-ascension obtained when the sidereal time is known. In some instruments, the vernier can be set to read the sidereal time at the instant, and then when the telescope is pointed to any object, the reading of the hour-circle gives at once its right-ascension. To point the instrument to any object of given right-ascension and declination it is then only necessary to rotate the instrument about the polar axis until the reading of the R.A. circle is equal to the right-ascension of the object and then to turn it about the declination axis until the reading of the declination circle, attached to that axis, is equal to the declination of the body.

Fig. 68 shows in a schematic form a common type of equatorial mounting. The telescope is supported at one end of the declination axis and counterpoised by a weight at the other end.

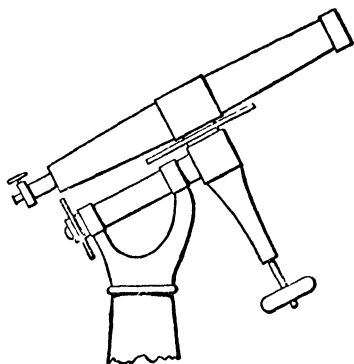

FIG. 68.—The Schematic Equatorial.

On all large instruments some type of mechanical counterpoise is introduced so as to reduce the friction of the polar axis in its bearings and to enable the instrument to turn freely. The form of equatorial mounting shown in Fig. 68 has some disadvantages in the case of heavy instruments: the necessity of counterpoising the telescope necessitates the stand of the instrument carrying a weight much greater than that of the telescope itself. Some large instruments are therefore made with the polar axis in the form of a rectangular framework of girders, supported at its two ends by independent supports. The declination axis is supported by pivots fitted to the two sides of this framework. An example of such a mounting is shown in Plate X, which represents the

100-inch Hooker telescope of the Mount Wilson Observatory.

It is necessary that the telescope should be adjusted so that the polar axis points accurately to the pole of the heavens and so that the polar and declination axes and also the telescope and declination axes are exactly at right angles. The first of these is an adjustment of setting and equatorial telescopes are generally provided with arrangements for adjusting in azimuth and for adjusting the tilt of the polar axis ; the second and third adjustments are instrumental, but require to be tested, as in general they require small corrections.

The clock should be controlled by an efficient governor so that the rate at which the telescope is turned does not vary. Some telescopes are fitted with an automatic electric controlling device, governed by a pendulum ; this device, invented by Sir Howard Grubb, consists of two parts, one of which, called the "detector," detects any irregularity in the clock drive ; and the other, called the "corrector," automatically corrects the error. The pendulum at the bottom of its swing touches a drop of mercury and so completes an electric circuit ; if the clock drive does not synchronise with the pendulum, the current passes round one or other of two circuits to the corrector ; an electromagnet causes an arrest to come into action and by a system of sun and planet pinions the rate of rotation is either accelerated or retarded until synchronization is obtained.

Equatorial telescopes, whether reflectors or refractors, are admirably adapted to photographic observation. It is necessary, when so used, that the image should be absolutely stationary and therefore it is customary to mount an auxiliary visual telescope on the same mounting : during the photographic exposure, the observer watches the image of the object in this telescope and controls the speed of the clockwork as necessary. Sometimes, however, it is simpler to fit an auxiliary arrangement to the photographic telescope by means of which an image can be seen which is formed by the same telescope that is used for the photographic purposes.

The large 40-inch refractor of the Yerkes Observatory is shown in Plate IX. The object-glass is the largest which has yet been constructed. The telescope is adapted for visual observation. The polar axis is relatively short ; near its lower end

may be seen the R.A. circle. The telescope is counterpoised by weights at the end of the declination axis. The focal length of the telescope is very long and it is therefore admirably suited to all purposes for which a large scale is essential. The size of the instrument may be judged from that of the chairs on the floor.

Plates X and XI show the 100-inch reflector of the Mount Wilson Observatory, California, and the 72-inch reflector of the Dominion Astrophysical Observatory, British Columbia, respectively. These are the two largest reflectors in the world. The difference in the methods adopted in the two instruments for suspending the telescope tube is of interest. In the 100-inch reflector, the polar axis is in the form of a cradle, supported at its two ends. The telescope itself is swung in this cradle, the declination axis consisting merely of two trunnions which fit into bearings in the cradle. No counterpoise weight is therefore necessary. In the 72-inch, on the other hand, the telescope is supported to one side of the polar axis and counterpoised by weights at the other extremity of the declination axis. In Plate XI, the telescope is shown with a spectroscope attached below the mirror, the light passing through a hole in the mirror. In the 100-inch telescope the mirror is not pierced with a central hole, the spectroscope being used as shown in Fig. 57 (*b*). The mountings of the large mirrors of these instruments are very carefully designed with a complicated counterpoise system, to prevent distortions arising from their great weight which would spoil their figure.

103. **The Filar Micrometer.**—If an equatorial telescope is used photographically, the photograph can be measured at any subsequent time. With a visual instrument, on the other hand, any measurements that are desired must be made at the telescope. The measurements most commonly required, such as the angular diameters of small bodies, or the angular separations of double stars, are usually made with a filar micrometer, fitted to the eye-end of the telescope. The micrometer consists of a rectangular box, containing three frameworks which carry spider-wires. One of these frameworks is fixed and usually contains two or three close parallel wires, running parallel to the length of the box; the other two

frameworks are movable in this direction by means of screws and micrometer heads, fitted to the two ends of the box. These frames each carry a single wire parallel to the short edges of the box and therefore perpendicular to the wires of the fixed frame. The frames are so constructed that the three sets of wires are all nearly in the focal plane of the object-glass and therefore can be focussed by the eye-piece together.

The entire box can be turned around in a plane perpendicular to the optical axis of the telescope. A graduated circle is fixed behind the micrometer box so that the angle through which the box is turned can be read.

In order to measure the separation of the components of a double star, the box is turned until the fixed wires are parallel to the line joining the nuclei of the two stars. The two micrometer heads are then turned until each wire bisects one of the star images, and the readings of the two micrometer heads are taken. The movable wires are then crossed over so that each bisects the other star and the readings again taken. From these readings, double the distance between the stars is at once obtained in terms of revolutions of the micrometer screws. The value of one revolution in angular measure can be readily obtained by observing a close circumpolar star, with the telescope fixed, the movement of the star in a certain interval of time being measured. The angular reading of the graduated circle gives the direction of the line joining the two stars; to convert into "position angle"—the angle measured from the north point—the telescope is stopped and the reading of the circle taken when the fixed wires are in such a position that the motion of any star is parallel to them. This gives the reading of the circle corresponding to a position angle of 90° .

104. The Spectroscope.—The purpose of the spectroscope is to analyse the light from any source into its constituent vibrations. Any spectroscope is composed of three portions: (i) The collimator, (ii) the dispersion piece, (iii) the telescope. The collimator, Fig. 69, consists of a tube, having at one end an achromatic object-glass and at the other a narrow slit, *S*, in its focal plane. The light from the source passes through the slit, emerges from the collimator as parallel light and then falls on the dispersion piece. This may consist either of a prism,

or a bundle of prisms or of a diffraction grating. The latter is a piece of glass or speculum metal ruled with numerous fine equidistant parallel lines, which has the property of analysing the light and reflecting each constituent vibration as a separate parallel beam. The light, therefore, emerging from the prism or reflected from the grating consists of a series of parallel bundles of different wave-lengths travelling in slightly different directions. The telescope focusses each of these as a line image, parallel to the original slit, and the spectrum produced may either be viewed with an eye-piece or photographed by placing a sensitive plate in the focal plane. With a fine straight slit to the collimator, the lines in the spectrum are

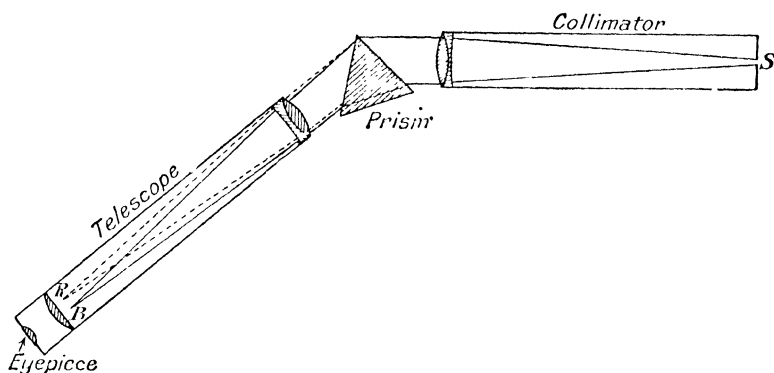

FIG. 69.—Diagram of Single Prism Spectroscope.

straight and sharply defined. In Fig. 69, *B* and *R* represent the foci for the blue and red rays respectively.

A spectroscope may be attached to the end of an equatorial telescope in order to obtain the spectra of stars. The image of the star produced by the objective must fall exactly on the slit of the spectroscope and accurate guiding is necessary in order to retain the image exactly in position.

At the Mount Wilson Observatory, the 60-inch reflector can be used for spectroscopic observations as a Cassegrain reflector in which the light is brought down the polar axis (Fig. 57 [b]). In this way, a massive spectroscope giving high dispersion can be utilized and can be easily kept at a constant temperature, which is of importance for some types of observation.

For astronomical purposes, the spectra are usually photo-

graphed so that their examination and measurement can be performed subsequently at leisure. It is customary then to give on the same plate a short exposure on either side of the stellar spectrum of the spectrum of a terrestrial source, such as the iron arc ; this enables the wave-length of many of the lines in the spectrum under examination to be assigned with considerable accuracy and it is then a fairly simple matter to deduce those of the other lines. The spectrum is impressed on the plate by reflecting the image of the arc on to the spectro-scope slit.

105. **The Heliometer.**—The heliometer is an instrument which enables the distances apart of neighbouring celestial

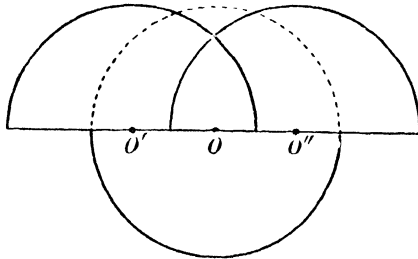

objects up to a limit of about a couple of degrees to be measured with a very high order of accuracy. As its name suggests, it can also be used for determining the angular diameter of the Sun. It consists essentially of a telescope, the object glass of which is divided into two along a diameter and the two parts mounted so that

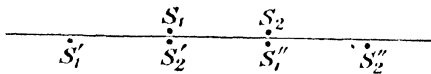

FIG. 70.—The Principle of the Heliometer.

they can be moved relatively to one another in a direction parallel to this diameter. The image of a point produced by a lens always lies on the line (produced if necessary) passing through that point and the centre of the lens. The effect of moving one half of the object glass is therefore to cause the image of a star produced by it to be displaced in a direction parallel to that in which the centre is displaced, i.e. parallel to the bounding diameter, and since the star is at a very great distance, the linear displacement of the image is equal to that of the object glass. Suppose, then, that two neighbouring stars are under observation and that the two halves of the object glass are not relatively displaced: they therefore produce

coincident images of the two stars S_1, S_2 (Fig. 70). If, now, the upper half, A , of the object glass is displaced to O' , the images produced by it are displaced to S_1', S_2' , and if the distance OO' is equal to S_1S_2 , the image S_2' will coincide with S_1 . Similarly, if displaced to O'' , where OO'' equals S_1S_2 , the images S_1'' and S_2 will coincide. If then the portion A is displaced by an accurate micrometer screw so that first the images S_2' and S_1 coincide and then S_1'' and S_2 , the total distance through which the object glass is moved, d , is twice S_1S_2 . The angular distance apart of the two stars is therefore $d/2f$, f being the focal length of the objective.

The heliometer was found of great value in the determination of the solar parallax by the minor planet method, the heliometer being employed to determine accurately the distances of the minor planet from several neighbouring stars. It also proved invaluable in observations for the determinations of stellar parallax, in which minute relative displacements of stars require to be measured. The observations which can be made with its aid can, however, now be made much more advantageously and with a great economy of time by photographic methods. With the heliometer, observations were slow and tedious, if great accuracy was sought; and considerable skill on the part of the observer was required. The instrument may therefore now be regarded as mainly of historical interest, although fewer than 50 years ago the results obtained by its aid were invaluable for the development of astronomical knowledge.

106. Zenith Telescopes.—The most accurate and convenient method for the measurement of latitude depends upon the determination of the difference in the zenith distances of two stars which culminate at nearly equal distances respectively north and south of the zenith. For this purpose, a special instrument called a zenith telescope is employed.

The ordinary type of zenith telescope is generally similar to a simple transit instrument, with the addition of an accurate declination micrometer to the eyepiece and of a sensitive latitude level to the telescope tube, the level being in the plane of the meridian. The telescope is set, before an observation, on a pair of stars, to the altitude approximately corresponding to their mean zenith distance, the setting being made with the

aid of a graduated circle. The latitude level is then set horizontal. As the first star crosses the meridian, its distance north or south of the central wire is measured with the aid of the micrometer and the reading of the level is taken: the instrument is then reversed, the setting of the level remaining unaltered and the position of the second star relatively to the centre wire determined and the reading of the level again taken. If the values in angular measure of one revolution of the micrometer screw and of one graduation of the level are known, the comparison of the two micrometer measures, corrected for the difference in level reading, gives the difference of the zenith distances of the two stars.

There are disadvantages attaching to the use of such a sensitive level as is required in the zenith telescope. Any inequality of temperature, such as warmth from the observer's body, is liable to upset the reading. In order to avoid the use of levels, a floating telescope was devised by Cookson and is in use at the Greenwich Observatory. The telescope floats in an annular trough of mercury and is simply rotated through 180° between the observations of the two stars of a pair. It must therefore rotate about an accurately vertical axis and no level correction is required. The observations with this instrument are made photographically.

CHAPTER VIII

ASTRONOMICAL OBSERVATIONS

107. **The Determination of Time.**—One of the most important and fundamental observations of astronomy is the determination of time. The problem reduces to the determination of the error of a time-piece and the method almost universally adopted in the observatory consists in observing with a transit instrument the time—as given by the sidereal clock—of the transit of a star across the meridian. The right ascension of a star at the instant of its meridian transit is equal to the sidereal time of that instant: therefore, if the right ascension of the star be known, the true sidereal time corresponding to the time given by the clock is determined and thus the error of the clock is obtained. The sidereal time at mean noon for the longitude of Greenwich is given for each day in the *Nautical Almanac*, and by interpolation the sidereal time at mean noon for any longitude can be obtained. The local mean time corresponding to any sidereal time can, therefore, be calculated.

For the purpose of time determination, a series of bright stars are used whose right ascensions have been determined from long-continued observations with very great accuracy. Such stars are called clock-stars. To obtain a good determination of the clock-error, several such stars should be observed. It is further necessary to correct the observed time of transit for the effect of the instrumental errors of collimation, level and azimuth as explained in § 97. Determinations of these errors should be made as nearly as possible to the time of the star observations.

From observations made on two consecutive nights, or during the course of a single night, the rate of the clock can be determined. Provided the clock is compensated against variations

of temperature and atmospheric pressure, this rate can be carried forward during spells of cloudy weather when stellar observations are not possible, without the liability of serious error being incurred.

There is one source of error known as the *personal equation* to which observations, which consist in the determination of the instant at which a star crosses a certain wire in the field, are liable. The estimation of the exact instant is a subjective phenomenon which differs with different observers. One observer may make the tap which completes the chronograph circuit when he judges the star to be bisected by the wire. Owing to the time required for the retinal stimulus to be transformed into muscular action, his tap will be slightly late: another observer may just anticipate the transit, so that he actually makes the tap at the exact moment that the star is bisected by the wire. Such an observer would record the time of transit earlier than the former observer. It is found that these personal differences may remain nearly constant for skilled observers, for long periods, though they are liable to change if the observer gets fatigued after a long spell of observing. They may amount to an appreciable fraction of a second of time. In the case of all differential observations such errors are eliminated, but they enter with full force into the determination of time. It is, therefore, desirable that the impersonal wire micrometer should be used: with this form of micrometer, the observer simply holds the star bisected by the wire by traversing the frame carrying the wire across the field of view with a steady motion and at the appropriate rate. The contacts which complete the electric circuit and send signals to the chronograph are then made automatically. With this type of micrometer, personal equations are reduced to a few hundredths of a second of time.

108. The Determination of Time at Sea.—The preceding method cannot be used at sea. The most convenient method is then to observe with a sextant the altitude of the Sun or Moon or of a known star. In the case of the Sun or Moon, the altitude observed is that of the lower or upper limb, which must be increased or decreased by the semi-diameter to obtain the altitude of the centre. The time shown by the chronometer

at the instant of the observation is noted. In order to determine the time, it is necessary that the latitude of the place of observation should be known: this must be determined from previous observation and, in the case of a ship in motion, corrected for the distance made good by the ship in the interval between the two observations.

Referring to Fig. 71, S represents the object observed, P the pole, and Z the zenith. ZP is the meridian. Then in the spherical triangle ZPS , the three sides are known; ZP is the complement of the latitude; ZS is the zenith distance or complement of the observed altitude, which must be corrected for refraction, for dip of the horizon, and, except in the case of a star, for parallax also. PS is the complement of the declination

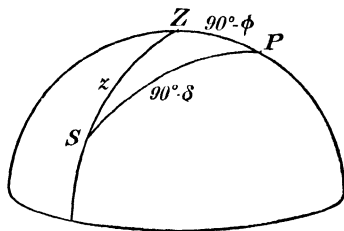

FIG. 71.—The Determination of Time at Sea.

of the object, which is known from the *Nautical Almanac*. The angles of the triangle can, therefore, be computed: the angle ZPS , which is the hour angle of the object at the time of observation, can thus be determined. This angle (expressed in time) added to or subtracted from the right ascension of the body, according as the star is west or east of the meridian, gives the sidereal time of the observation.

Instead of a single altitude, a series of altitudes in quick succession should be observed and the mean altitude and mean time used for the computation. The method is the more accurate the nearer the object is to the prime vertical, for then the rate of change of the altitude with the time is most rapid. Near the meridian, the method is very insensitive as the change in altitude is then so slow. The effect of an error in the assumed latitude is also least when the object is exactly east or west. The altitude to be observed should not be less than about 10° , as at lower altitudes, somewhat large errors would be introduced on account of the uncertainty of the amount of the refraction so near the horizon.

109. The Determination of Latitude.—(i) *The Talcott Method.*—The most accurate method for the determination of

latitude is that known as the Talcott method, after Captain Talcott of the United States Engineers, who used it in 1845 in a boundary survey. The method consists in the determination, with the aid of a zenith telescope, of the difference between the meridian zenith distances of two stars of known declinations which culminate at nearly equal distances respectively north and south of the zenith. If ϕ is the latitude, $\delta_s, \delta_n, \zeta_s, \zeta_n$ the declinations and meridian zenith distances of the south and north stars respectively, then

$$\begin{aligned}\phi &= \delta_s + \zeta_s = \delta_n - \zeta_n \\ &= \frac{1}{2}(\delta_s + \delta_n) + \frac{1}{2}(\zeta_s - \zeta_n)\end{aligned}$$

The zenith telescope (§ 106) provides an accurate determination of $(\zeta_s - \zeta_n)$ and the declinations of the stars are known. Hence the latitude is determined.

The method has the great advantages of avoiding almost entirely errors due to refraction and of not requiring an accurately graduated circle. A rough setting of the instrument is sufficient, the difference of the zenith distances being measured by the micrometer screw.

(ii) *By Circumpolars*.—A simple method of determining latitude, which is suitable for observations with a fixed meridian circle, is to observe the altitudes of a close circumpolar star at its upper and lower culminations, with an interval of 12 hours between the observations. Each altitude must be corrected for refraction and their mean determines the latitude, the altitude of the pole being equal to the latitude. The method is not suitable for low latitudes, as refraction then becomes very large for circumpolar stars.

(iii) *Sun's Maximum Altitude*.—Observations at sea must be made with a sextant, and the method best adapted to this purpose is to observe the maximum altitude of the Sun. Observations should be commenced a few minutes before local apparent noon and a succession of altitudes observed until the values begin to decrease. The maximum value obtained (after correction for the northward or southward motion of ship, for refraction, parallax, dip of the horizon, semi-diameter and motion of the sun in declination) gives the latitude by the formula $\phi = \delta \pm \zeta$, the sign being + or - according as the Sun is south or north of the zenith.

(iv) *By the Use of the Gnomon.*—This is a method of merely historical interest, as it was the only method available to the ancients. A vertical stick or column is erected on a horizontal piece of ground and the length of its shadow is observed at noon each day. This length varies from day to day owing to the changing declination of the Sun: it is greatest at winter solstice, when the Sun's midday altitude is least, and it is least at summer solstice. If AB (Fig. 72) is the gnomon, S_1 , S_2 the ends of the noon shadows at the winter and summer solstices respectively, the angles ABS_1 and ABS_2 can be calculated: these determine the Sun's maximum and minimum zenith distances. The mean of these angles, therefore, gives the distance of the equator from the zenith, for at winter solstice the Sun is as far south of the equator as at summer solstice it is north of it. But the distance of the zenith from the equator is equal to the distance of the pole from the horizon, i.e. is equal to the latitude.

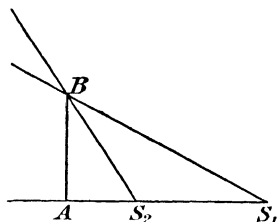

FIG. 72.—The Gnomon.

110. The Determination of Longitude.—Whilst the poles of the Earth's axis of rotation serve as universal reference points for the determination of latitude, there is no corresponding reference point for longitudes. The determination of longitude is, therefore, a more intricate problem. It was to the necessity of providing accurate observations of the Moon and fixed stars for use in determining longitude at sea that the observatories of Greenwich and Paris owe their foundation.

The meridian passing through Greenwich is adopted as the arbitrary zero from which longitudes on the Earth are measured. The longitude of any other place on the Earth's surface is measured by the arc of the equator intercepted between the meridians through that place and through Greenwich respectively. Longitudes are usually measured in time, and the difference of longitude between any two places is then the time required for the Earth to turn through an angular distance sufficient to bring the meridian of one of the places

into the position held by the other. The difference of longitude is therefore the difference of the local times at the two places. We have already explained in § 107 how the local mean time at any place may be found: the problem therefore reduces to finding the corresponding local time at the other place without going there. Alternatively, if any common phenomenon can be observed from each of the two places and the local time of its occurrence at each place determined, the difference of the local times will give the longitude difference.

(i) *By Telegraphic Signals.*—The most obvious method by which to connect the two places is by telegraphic signal, and this provides also the most accurate method of determining a difference of longitude. Formerly an ordinary telegraph cable was employed for the transmission of the signals, but the development of wireless telegraphy has superseded the use of a cable and has greatly facilitated the determination of longitudes. There are few parts of the Earth which are not now within range of one at least of the high-powered wireless transmitting stations which send out daily, at certain specified times, a series of time signals. These are emitted at definite standard times, and if an observer compares the time at which these signals are received with the time by his clock, whose error has already been determined from stellar observations, he has at once the material for determining the difference between his longitude and that of the standard meridian.

For the accurate determination of the difference of longitudes of any two stations, some further precautions must be taken. Observers must be stationed at each place and signals from some station must be observed and the times of reception compared. Special precautions must be adopted to avoid the possibility of personal or systematic errors entering into the result. It was formerly customary to interchange observers in the middle of the series of observations in order to eliminate as far as possible personal errors: but the use of impersonal micrometers renders this precaution hardly necessary. When a telegraph cable was used, it was necessary to compare the chronograph at each station with that at the other by means of special signals sent in both directions so as to determine the time occupied in the transmission of the signals. The velocity of wireless waves, on the other hand, is equal to that of light

and can therefore be neglected unless super-refinement is sought.

(ii) *Longitude at Sea*.—In order to determine longitude at sea every ship carries an accurate time-piece called a chronometer, whose error and rate must be determined prior to the voyage. If this chronometer is set to give Greenwich time and the local time is determined by observation of the Sun's altitude when near the prime vertical, the longitude can be obtained. The accuracy of the result is dependent upon the chronometer maintaining its rate without variation, but wireless time signals now provide a check upon its behaviour: a comparison of the chronometer with the time of reception of signals emitted at a definite Greenwich time enables the error of the chronometer to be determined and the constancy or otherwise of its rate verified.

(iii) *Eclipses of the Satellites of Jupiter* may be used to determine longitude, since they occur at the same instant for all observers and therefore provide a common reference signal. They also occur with sufficient frequency to be of use. Unfortunately, the disappearance of a satellite when eclipsed is gradual and not instantaneous as is the case when a star is occulted by the Moon; the accuracy obtainable by this means is therefore not very high.

(iv) *Observations of the Moon*.—One of the oldest methods of determining longitudes is based upon the use of the Moon as a clock, and although the telegraphic method is now used almost exclusively, this method is not without interest. The Moon changes its place amongst the stars, and therefore also its right ascension and declination, much more rapidly than any other celestial object. Its position in the sky is given in the *Nautical Almanac* for every hour of Greenwich time throughout the year. If then the position of the Moon amongst the stars is observed and corrected for parallax, so as to reduce the observation to one made by an observer at the centre of the Earth, the Greenwich time of the observation can be estimated by interpolation from the *Nautical Almanac* tables, and a means provided for the determination of longitude. The disadvantage of the method is that the motion of the Moon amongst the stars is relatively slow, so that errors of observation enter into the deduced longitude magnified about thirty times.

The observation of the Moon may consist either (i) in the

determination of its right ascension at the instant of meridian passage with the transit circle, the error of the clock having been determined by star observations (which method has the advantage that no correction for parallax is necessary) or (ii) by observing the distance of the Moon from stars near its path—which is the method suitable for use at sea with a sextant: the distances must be corrected for parallax and compared with tables constructed for the purpose; (iii) alternatively, if an occultation of a star by the Moon is observed at two places, the longitude difference can be deduced; the theory in this case is similar to that by lunar distances, the distance of the star from the centre of the Moon being then equal to the Moon's semi-diameter.

111. The Determination of Position at Sea.—The older methods of determining the position of a ship at sea depended upon separate observations for the latitude, obtained by determining the Sun's meridian altitude, and for the longitude, depending upon observations of the Sun's altitude when near the prime vertical, and for which a knowledge of the latitude was essential.

These methods have been largely superseded by a more convenient and accurate method, first proposed by Captain Sumner, of Boston, in 1843. Several modifications of the method have been employed, but they all depend essentially upon the observation of an altitude of the Sun, Moon, or star with the corresponding chronometer time.

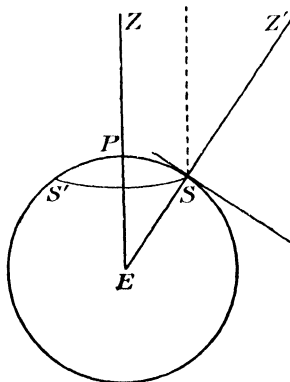

FIG. 73.—The Sub-Solar Point.

In Fig. 73, SPS' represents a section of the Earth and E its centre. Suppose that, at any instant, the Sun is in the zenith Z of the point P and that at another point S is a ship, Z' being in its zenith. Then since the angle between the horizons at the points S and P is equal to the angle SEP , it follows that the zenith distance of the Sun observed from S will also be equal to this angle. If SS' is a small circle with its centre

at P and with radius equal to the angle SEP , at every point on this circle the zenith distance of the Sun will be the same. If, then, the point P can be determined and the Sun's zenith distance obtained from the altitude observation, the circle SS' can be drawn on the chart and the position of the ship must be somewhere on this circle. Actually, the position is approximately known from dead-reckoning observations and therefore it is only necessary to draw a small portion of the circle in the neighbourhood of the dead-reckoning position. This is the basis of Sumner's method of determination of position.

The point P is called the sub-solar point. Since the Sun (or other body under observation) is in its zenith, it follows that the latitude of P must equal the declination of the Sun (or other body) at the moment of observation. This can be obtained from the *Nautical Almanac*, if the Greenwich Mean Solar Time at the moment of observation is known. This is obtained in the usual way from the chronometer corrected for error and rate to the moment of observation. The longitude of the sub-solar point is the angle between the meridians of Greenwich and the Sun, since the Sun is on the meridian of the sub-solar point. This angle is the Greenwich Apparent Time of the moment of observation, which is equal to the Greenwich Mean Time plus the equation of time. In the case of the Moon or of a star, it is obtained by adding to the Greenwich Mean Time the right ascension of the mean Sun (obtainable from the *Nautical Almanac*) and subtracting the right ascension of the Moon or star. The position of the sub-solar point (which is fixed by its latitude and longitude) can therefore be obtained without difficulty and the corresponding Sumner line drawn.

As the radius of the Sumner line may be large, it is more accurate to use the following method for drawing it on the chart: a convenient assumed position for the ship is chosen, which must be somewhere near its true position, e.g. the dead-reckoning position might be adopted: then, since the latitude and the longitude of the sub-solar point are known, the altitude of the Sun as observed from this assumed position can be readily calculated. If this computed altitude agrees with the observed altitude, the assumed position must lie on the Sumner line, and a line drawn on the chart through this point in a

direction perpendicular to the bearing of the Sun will be the required line of position. If, as will generally happen, the computed altitude is smaller than or greater than the observed altitude, then the assumed point is respectively outside or inside the Sumner line: if from the assumed point, in the direction of the bearing of the Sun, a distance is measured towards or away from the sub-solar point equal to the difference between the observed and computed altitudes (using the relationship 1 nautical mile equals 1 minute of arc), a point on the Sumner line is obtained, and the line itself is obtained by drawing a line through that point on the chart at right angles to the Sun's bearing.

If a second Sumner line can be drawn for the same instant, then since the ship must be on this line also, the intersection of the two lines will give its position. To construct the second line, the same object may be observed somewhat later: the motion of the ship in the meantime is known with sufficient accuracy from the compass course and log, and to take the run between the two observations into account the first Sumner line must be shifted parallel to itself by an amount corresponding to this run. The intersection of this shifted line with the second line determines the position of the ship at the time of the second observation. Another method of obtaining the second Sumner line is to observe two bodies, say the Sun and the Moon, with as short an interval as possible between them. The essential thing to secure is that the two lines should intersect as nearly as possible at right angles, so that the point of intersection may not be affected too much by errors of observation.

Instead of actually plotting the two lines on the chart and determining their point of intersection, this point may be determined by computation; for the details of which reference should be made to a treatise on navigation.

The advantage of the Sumner method is that both the latitude and longitude of the ship are determined from two observations at any convenient time of the altitude and bearing of a body, with the corresponding chronometer times. With the older methods, a determination of latitude was necessary by means of a noon-sight (a knowledge of the longitude not being necessary), and then a determination of longitude by a time-sight, for the reduction of which a knowledge of the

latitude is necessary. Any error in the determination of latitude therefore enters also into the determination of longitude and, in addition, some time probably elapses between the two observations, so that errors in the dead reckoning also enter into the latitude assumed for the time-sight. The Sumner method is the best method to use under any circumstances, and even when a noon-sight is taken it is advisable to treat it as a Sumner observation and to work out the corresponding Sumner line.

112. Determination of Right Ascension and Declination.—The position of any celestial object is defined by its right ascension and declination. These are best determined with the aid of the meridian circle.

The right ascension of a body is the sidereal time at which it crosses the meridian, and therefore all that is necessary for its determination is to find first the error and rate of the clock, and then to observe the time of meridian passage of the body, which must be corrected for errors of collimation, level and azimuth.

The declination of the object is obtained from the circle reading at the instant of meridian passage, corrected for the effects of refraction and, if necessary, of parallax. The zero of the circle may be determined from observation of the *nadir* point with a mercury horizon, as previously explained. In effect, the zenith distance of the body is observed, and, the latitude being known, the declination is deduced. Alternatively, observations of close circumpolars at an interval of 12 hours, and corrected for refraction, may be used. The circle reading corresponding to the pole is thus obtained, and so the north-polar distance, and therefore the declination, are directly determined.

Observations with the meridian circle may be divided into two classes: fundamental and differential. Fundamental work consists in the absolute determinations of positions of certain stars which are then known as *fundamental* stars; differential work consists in observing the positions of objects relatively to one or more of the fundamental stars so that only the differences in their right ascensions and declinations are actually observed and any instrumental errors enter into the

final result with much less weight than in an absolute determination.

We have mentioned that the error of the clock is determined from the observation of certain stars whose right ascensions are known with great accuracy and that the determination of right ascension involves a knowledge of the clock error. Although this is the method adopted in practice, it is in reality arguing in a circle. The method used to determine the right ascensions of the clock stars must be explained. Right ascensions are measured from the vernal equinox, the imaginary point at which the Sun crosses the equator. The absolute determination of a right ascension therefore necessarily involves a comparison of the star with the Sun. The procedure is to observe the clock time of meridian transit of the Sun and its declination at that instant on every possible day throughout the year. The clock times of transit of the stars chosen as clock stars are also obtained throughout the year, during the periods when they are visible. The observations of the Sun's declination provide a determination of the obliquity of the ecliptic: using the value so derived, every observation of the Sun's declination gives by trigonometric computation a value for its right ascension. Any small error in the adopted value of the obliquity will be almost entirely eliminated in the mean since it will have opposite effects at winter and summer solstices. The sidereal time at the moment of the Sun's transit is equal to its right ascension and therefore by comparing the computed right ascension with the corresponding observed clock time of meridian transit the clock error is deduced. Successive observations determine the clock rate, and by interpolation the clock error corresponding to the instant of any of the star transits can be determined. By correcting the clock time of transit for this error the right ascension of the star is obtained. By the accumulation of observations, these right ascensions become accurately known, and they can then be used as a basis for the determination of other right ascensions by the methods previously described.

113. Reduction of Star Places from one Epoch to another.—Direct observation gives the *apparent* place of a star, i.e. its position as actually seen by an observer on the

Earth, referred to the actual pole and equinox at that date. The *mean* place is the position at the same instant as it would appear to an observer at rest on the Sun. The mean and apparent places vary from epoch to epoch on account of the fact that the pole and the equinox are not exactly fixed, owing to the effects of precession and nutation, and also because the stars themselves are in motion; their distances are, however, so great that their apparent angular motions are in general small, even over a period of a century. To reduce the apparent place to the mean place at a definite epoch corrections must be applied for precession, nutation, aberration, annual parallax, and for the proper motion of the star. These reductions may be expressed in the form :

$$\Delta\alpha = Aa + Bb + Cc + Dd + E + \mu_a\tau$$

$$\Delta\delta = Aa' + Bb' + Cc' + Dd' + \mu_\delta\tau$$

In these formulæ, A , B , C , D , and E are independent of the position of the star, but are functions of the time. At any definite time they are therefore the same for all stars, but they vary slowly from day to day. They are known as *Besselian day numbers*, after the astronomer Bessel, who first introduced them. In the *Nautical Almanac* they are tabulated for every day of the year. The quantities a , a' , b , b' , etc., on the other hand, are functions of the place of the star, but are practically independent of the time, though they vary slowly over a period of years. They are therefore termed the star constants. The terms depending on A , B , and E in the above formulæ arise from the effects of precession and nutation; those depending on C and D from aberration and parallax. The last term in each formula represents the effect of proper motion. These formulæ are used to reduce the observed positions of a star to the mean position at the commencement of the year in which the observations were made. To reduce from this position to the mean position at any other epoch a reduction for the effects of precession and proper motion must be applied. For a rigorous reduction, trigonometrical methods must be employed, for details of which reference should be made to a treatise on spherical astronomy. In the case of stars which are not too close to the pole and for periods of time which are not more than a few score years, an approximate reduction is sufficient, using the formulæ :—

$$\alpha_t = \alpha_0 + at + \frac{1}{2} \frac{b}{100} t^2$$

$$\delta_t = \delta_0 + a't + \frac{1}{2} \frac{b'}{100} t^2$$

In these formulæ α_t , α_0 ; δ_t , δ_0 denote respectively the right ascensions and declinations at the initial period and at a period t years later. The annual variations a and a' include precession and proper motion and are usually given in star catalogues without the proper-motion component. The proper motions, if known with sufficient accuracy, may be given separately. The terms b and b' are called the secular variations and are also usually tabulated in the catalogues.

114. Determination of Azimuth.—This is a problem of importance to surveyors and also to astronomers. The most accurate method is to observe with a theodolite, which has been carefully adjusted for collimation and levelled, the angle between the pole star and either a distant fixed object or the cross wires of a suitable rigid collimator. The time of the observation of the pole star must be noted; its right ascension and declination for that instant can then be obtained from the *Nautical Almanac*, and, knowing these, its azimuth can be calculated. The azimuth of the collimator or distant object may then be obtained, and used as a zero from which the azimuth of any other body may be observed.

In order to compute the azimuth of the pole star, the latitude of the place of observation must be known. The advantage of using this star is that any slight errors in the assumed latitude or in the observed time of observation produce very little effect on the deduced azimuth. If the time of observation is determined very accurately, the Sun or a star whose altitude is not greater than about 30° may be used, but, in general, the pole star will be found most suitable and accurate for the purpose.

CHAPTER IX

THE PLANETARY MOTIONS

115. The Planets.—The so-called fixed stars retain their relative positions on the celestial sphere with such accuracy that refined observations are necessary to detect their motion. It was known to the ancients that there were a few bodies which moved about amongst the other stars, and these were called planets or wanderers. Under this term they included Mercury, Venus, Mars, Jupiter, and Saturn, as well as the Sun and the Moon. The term planet is now restricted to the bodies which revolve in definite orbits about the Sun. It includes, in addition to Mercury, Venus, Mars, Jupiter, and Saturn, the Earth and the two distant bodies, Uranus and Neptune, which were unknown to the ancients, in addition to a very large number of smaller bodies, termed minor planets or asteroids, whose orbits lie between those of Mars and Jupiter. The Sun, the central body of the system, and the Moon, the satellite of our Earth, are not now regarded as planets.

116. Kepler's Laws.—From a study of the extensive and long-continued planetary observations of the Danish astronomer, Tycho Brahe (1546–1601), Kepler between 1607–1620 formulated three empirical laws which he found were satisfied by the motions of the planets. These laws are as follows :—

1. The orbit of each planet is an ellipse, having the Sun in one of its foci.

2. The motion of each planet in its orbit is such that the radius vector from the Sun to the planet describes equal areas in equal times.

3. The squares of the periods in which the planets describe

their orbits are proportional to the cubes of their mean distances from the Sun.

It will be seen that the first two laws deal with the motion of any one planet. The third gives a relationship between the periods and distances of the several planets. Thus, if the period of any planet be known, its mean distance from the Sun in terms of the Earth's mean distance as unity can be determined. A determination of any one distance in the solar system therefore enables all the other distances to be determined, since the periods can easily be obtained by observation.

The physical meaning of these laws was discovered by Newton. He showed that all three laws could be explained on the hypothesis that each planet moves under the action of an attractive force towards the Sun, proportional to the planet's mass and to that of the Sun and inversely proportional to the square of its distance from the Sun. The constant of proportionality is the same for all the planets and is called the constant of gravitation.

It is desirable to make a distinction between the consequences involved in the three laws of Kepler. The second law necessarily implies that each planet moves under a force of attraction always directed towards the Sun. Moreover, with such a force, which in mechanics is called a "central" force, whatever the law which it obeys, equal areas must be described in equal times. This may be shown from elementary considerations. In Fig. 74 S represents the attracting centre. Suppose first that a body is moving along the line ABC and that there is no attracting force; then its motion must be uniform and if AB , BC are lengths described in unit times, AB and BC are equal. Hence also the triangles SAB , SBC must be equal and the theorem is valid. Now suppose that at the moment B , a velocity of any amount is suddenly applied to the body in the direction BS which in unit time would take it to the point b . Constructing the parallelogram, $bBCc$, it must actually in unit time move to c , and the area described by the radius vector is the triangle Sbc . But since Cc and SB are parallel, the triangles SCB , ScB , being on the same base and between the same parallels, must be equal. The area described by the radius vector in unit time will therefore be unaltered. Now suppose the attracting force to act continuously towards

S ; whatever its amount, its effect is to produce changes of velocity in the direction of the radius vector, and we have just seen that these do not affect the rate of description of areas. Equal areas will therefore be described in equal times. The converse theorem must also hold, viz. that if equal areas are described in equal times, the force must be a central one, for if the velocity added at the point B was not along BS , the areas of the two triangles SBC , Sbc would not be equal.

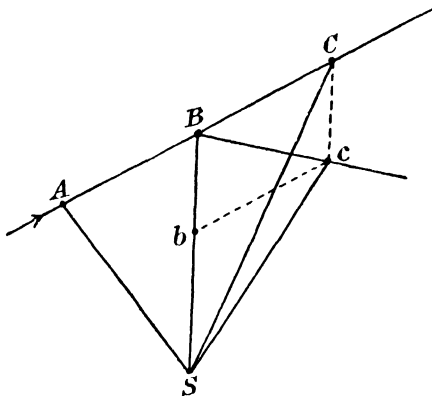

FIG. 74.—The Law of Equal Areas.

Kepler's third law involves the universality of the constant of gravitation. This may be illustrated for the simple case of circular orbits. If M is the mass of the central body, m that of the attracted body, a the radius of the orbit, w the angular velocity of the body, and T its period, then equating the radial acceleration of the body to the force of attraction we have

$$\frac{GMm}{a^2} = maw^2 = m \cdot \frac{4\pi^2}{T^2} a$$

or

$$GM = 4\pi^2 \frac{a^3}{T^2}.$$

If for another body moving around the same central body the radius of the orbit and the period are respectively a' , T' and the constant of proportionality G' ,

$$G'M = 4\pi^2 \frac{a'^3}{T'^2}$$

Therefore $G/G' = \frac{a^3}{T^2} \bigg/ \frac{a'^3}{T'^2} = 1$ (by Kepler's third law) or $G = G'$.

Applying the case of a circular orbit to the motion of the Moon around the Earth and denoting by g the force of gravity at the Earth's surface, then the Earth's gravitational force

at the distance of the Moon will be gR^2/a^2 , R, a being respectively the radius of the Earth and the distance of the Moon. But this force can also be expressed as GM/a^2 . Hence

$$G\frac{M}{a^2} = g\frac{R^2}{a^2} = 4\pi^2\frac{a}{T^2}$$

M denoting here the mass of the Earth, now considered as the attracting body.

Trigonometric measures give $a/R = 60.27$ and the radius of the Earth is 6.367×10^6 metres. The period of revolution is 27 d. 7 h. 43 m. = $39,343 \times 60$ seconds. Therefore

$$g = (60.27)^3 \times 4\pi^2 \times 6.367 \times 10^6 / (39343 \times 60)^2 = 9.81 \text{ metres per sec. per sec.}$$

$$= 981 \text{ cms. per sec. per sec.}$$

This agrees with the observed value of gravity at the Earth's surface. It follows that the gravitational force which holds the Moon in its orbit is the same as that which attracts a body to the Earth's surface.

Newton was in this way led to the universality of the law of gravitation. It follows that the planets must exert mutual gravitational forces upon one another; the magnitudes of these are very much smaller than that of the force due to the Sun, on account of the much greater mass of the latter. The effect of the combined forces is that the orbits are not accurately elliptical, slight deviations occurring when two planets pass near one another. It was due to the small deviations of Uranus from its predicted position that Adams and Leverrier were independently led to the discovery of the then unknown planet Neptune. From a mathematical discussion of the discordances between prediction and observation, they were able to show that these discordances could be accounted for if there was a more distant planet whose attraction was disturbing the motion of Uranus, and they were able also to assign an approximate position to this planet, near which it was discovered as a direct result of their investigations.

It should be mentioned that Kepler's third law is not strictly accurate, though the discordance is very small. It would be accurate provided that the masses of the planets were negligible. Actually, they exert an attraction on the Sun, and the attractive force per unit mass, relative to the Sun, is therefore

$G(M + m)/a^2$. The accurate form of Kepler's law is thus :
 $(M + m)T^2 : (M + m_1)T_1^2 = a^3 : a_1^3$
 m, m_1, M being the masses of the two planets and of the Sun.

117. Apparent Motions of the Planets.—The apparent motions of the planets as seen from the Earth are the resultant of the actual motion of the planet around the Sun and an apparent motion due to the Earth's own orbital movement. This combination of two distinct velocities produces certain peculiarities in the apparent motion which we shall proceed to describe.

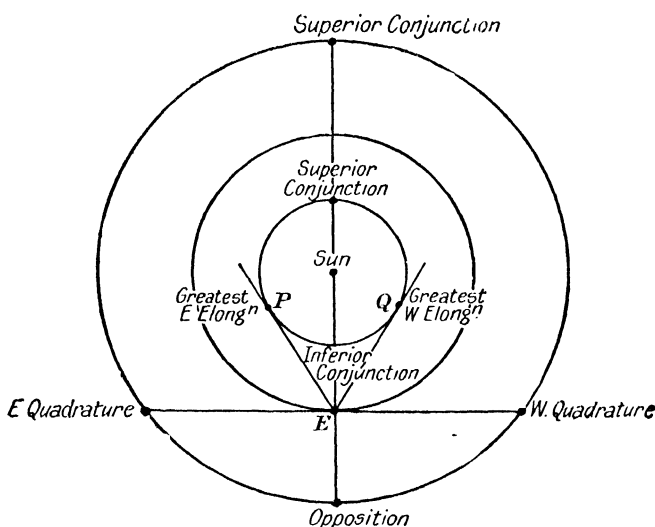

FIG. 75.—Planetary Configurations.

Certain terms commonly used in connection with planetary motions must first be defined. When the planet is in a line with the Sun and the Earth, it is said to be in *Superior Conjunction*; when an inferior planet (i.e., a planet whose orbit is within the Earth's orbit) is in a line with the Sun and Earth and between them, it is said to be in *Inferior Conjunction*. The corresponding position for an outer planet is when the Earth is between the Sun and the planet, and the planet is then said to be in *Opposition*. In the case of an outer planet, when the direction from the Earth to the planet is at right angles to that from the Earth to the Sun, the planet is said to be in *quadrature*.

east or west, according as it is east or west of the Sun. The angle Planet-Earth-Sun is called the *Elongation* : for an outer planet this angle can have any value from 0 to 180° ; for an inner planet it varies between 0 and a maximum, less than 90° , called *Greatest Elongation*, whose value depends upon the relative sizes of the orbits of the Earth and the planet. The positions of greatest east and west elongations are shown in Fig. 75, which illustrates also the other configurations, defined in this paragraph.

The apparent motion of a planet can now be described, starting from superior conjunction. The planet at first moves eastwards amongst the stars, increasing its right ascension. After a certain time, the apparent motion becomes less and then vanishes, the planet being said to be *stationary* in this position. The elongation of this position depends upon the size of the planet's orbit. After reaching the stationary position, the planet begins to move westward, with decrease of right ascension. It is then said to *retrograde*. The middle of the period of retrogression occurs at inferior conjunction for an inferior planet and at opposition for an outer planet. The retrograde motion is succeeded by a second stationary point and

then by eastward motion, motion bringing the planet back to superior conjunction. The time spent in the direct motion always exceeds that spent in the retrograde motion.

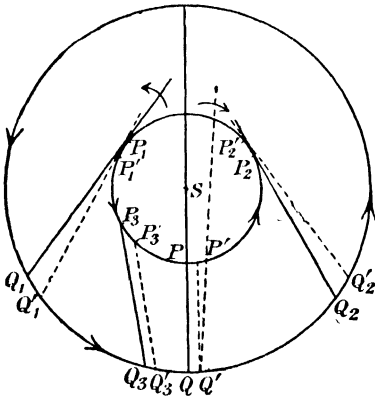

FIG. 76.—Explanation of Planetary Motions.

118. Explanation of Apparent Motions.—We can now show how the apparent motions can be explained by the combination of the velocities of the Earth and the planet.

In Fig. 76, *S* represents the Sun, *P* and *Q* any two planets in conjunction on the same side of the Sun, *P'* and *Q'* represent the corresponding positions of the two planets after a short interval of time. For

simplicity, it will be assumed that the orbits are circular; since the eccentricities of the planetary orbits are small, the qualitative description of the phenomena will not thereby be affected.

According to Kepler's third law, the ratio of the periods of P and of Q is equal to $(SP/SQ)^{3/2}$. Also

$$\begin{aligned} PP'/QQ' &= \text{velocity of } P / \text{velocity of } Q \\ &= \frac{SP \times \text{angular rate of motion of } P}{SQ \times \text{angular rate of motion of } Q} \\ &= \frac{SP}{\text{periodic time of } P} \bigg/ \frac{SQ}{\text{periodic time of } Q} \\ &= (SQ/SP)^3. \end{aligned}$$

Therefore since SQ is greater than SP , PP' is greater than QQ' .

Let us now suppose Q to be the Earth and P any inferior planet. For certain corresponding positions, P_1 and Q_1 , also P_2 , Q_2 of the two bodies, the line joining them is tangential to the inner orbit. When the planet moves a short distance to P_1' , which is practically on the line P_1Q_1 , the Earth moves to Q_1' and the apparent direction of motion of the planet projected on the celestial sphere is evidently the same as the direction in which the orbits are described, i.e. direct. At inferior conjunction, on the other hand, since PP' is greater than QQ' and each is at right angles to PQ , the apparent position of the planet in the heavens when the Earth is at Q' is displaced forward as compared with its position seen from Q , i.e. in a direction opposite to that in which the orbits are described, and the apparent motion is therefore retrograde. At the positions P_2Q_2 , the apparent motion is evidently again direct. It follows that at some point between Q_1 and Q , and also between Q and Q_2 , the motion changes from direct to retrograde, and conversely. These are the stationary points. If P_3 , Q_3 denote one of them, the consecutive positions P_3' , Q_3' are such that P_3Q_3 and $P_3'Q_3'$ are parallel.

For the case of a superior planet, we can suppose P to be the Earth and Q the planet. Then, remembering that the apparent position of the planet is now given by the line PQ produced (not QP as before), a similar line of reasoning proves that when

the Earth is at P_1 and P_2 , the apparent motion is direct, at P is retrograde, and at P_3 is stationary.

It follows, from the preceding, that if each planet is seen from the other, the apparent motion of each planet will be exactly the same at the same time, i.e. both retrograde, both stationary, or both direct.

119. The Ptolemaic System.—It is of interest to examine in what manner the apparent motions of the planets were accounted for by the ancient astronomers who believed the Earth to be fixed and the centre of the celestial universe. The hypothesis advanced by Ptolemy about A.D. 140 was universally accepted for fourteen centuries and continued to receive a large measure of assent for some time after Copernicus advanced the theory that the Sun was at rest and that the Earth in common with the other planets moved round it. Ptolemy supposed that to each planet belonged a circular orbit, called the planet's *deferent*. The planet did not itself move

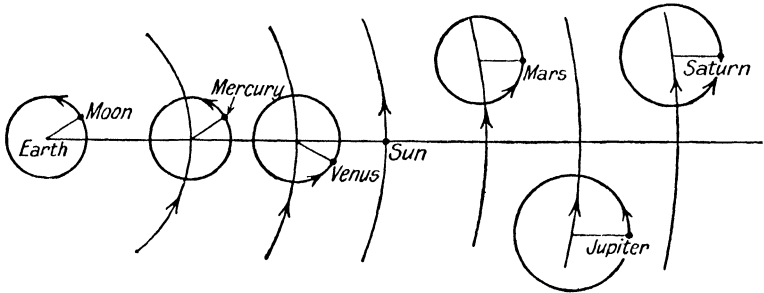

FIG. 77.—The Ptolemaic System.

upon the deferent, but moved around the circumference of a smaller circle called the *epicycle*, whilst the centre of this circle moved round the deferent. Thus the actual motion of a planet was compounded of two uniform circular motions, the motion of the deferent and that of the planet relative to the deferent. In the case of the Sun and the Moon, there was no epicycle, these two bodies moving around their deferents.

The deferents of Mercury and Venus were inside the deferent of the Sun and it was supposed that the centres of their epicycles revolved around their deferents in a period of one year and in such a manner that the line joining them always passed through

the Earth and through the Sun. The periods relative to a fixed direction of the epicyclic motions in the case of these two planets were equal to what we now know as the periods of the two planets. The revolution of Mercury and Venus in their epicycle, evidently on this theory, will make them swing backwards and forwards alternatively east and west of the Sun, for limited angular distances only, in accordance with the observed motions. Also, if the linear velocity of the epicyclic motion is greater than that of the epicyclic centre along the deferent, the apparent motion will appear retrograde near the point where the planet crosses the line joining the Earth and the Sun, on the side towards the Earth. The deferents of Mars, Jupiter, and Saturn were exterior to that of the Sun, and the epicyclic radii at the ends of which the planets were situated were supposed always to be parallel to the line joining the Earth and the Sun. This ensures that retrograde motion, which will only appear near the position of the planet in its epicyclic motion in which the radius from the centre of the epicycle to the planet passes through the Earth, will only occur when the planet is in line with the Sun and Earth.

Each deferent was supposed to be carried on the surface of a perfectly transparent crystal sphere, and all these spheres rotated once a day about an axis passing through the poles of the heavens. The fixed stars were supposed to be attached to an outer crystal sphere which rotated with the others. This common rotation, from east to west, gave rise to the diurnal phenomena which we now attribute to the rotation of the Earth.

This theory was able to account successfully for the general features of the observed motions of the planets; it explained the direct and retrograde motions and the observed periods of revolution relatively to the Sun. As observations became more accurate, it was found that the theory did not entirely account for the actual motions, and it then became necessary to complicate the theory by adding additional epicycles, i.e. by supposing that the planet moved around an epicycle, the centre of which moved around a second epicycle, the centre of this epicycle moving around the deferent. It was also necessary to suppose that the Earth was not exactly in the centres of the deferents nor the centres of the epicycles exactly

on the deferents. The observed irregularities of motion were thus explained, but at the expense of making the theory more and more artificial.

Copernicus (1473–1543) was the first to assert that the diurnal rotation of the Earth was the true explanation of the diurnal motion of the stars and that the planets, including the Earth, revolved around the Sun. He supposed their orbits to be circular and therefore was obliged to retain some small epicycles to account for the principal irregularities. The great objection raised against this theory was that if the Earth did revolve around the Sun in this way, the fixed stars should change their apparent relative positions in the sky. If, for instance, there were two stars which were on a line passing through the Sun, one more distant than the other, then as the Earth rotated in its orbit, the nearer one would appear at one time on one side of the more distant star and six months later would appear on the other side. The most accurate observations at that time failed to reveal any such relative displacements, and this led Tycho Brahé and other astronomers to reject the theory of Copernicus. The explanation of this negative result is, of course, to be found in the very great distances of the stars; by modern methods the displacement can be observed, and it affords a means of measuring the distances of the stars, as we shall see later.

It was not until the time of Kepler, about 65 years after Copernicus, that the planetary orbits were shown to be not circular but elliptical, and his work, with the theoretical explanations given by Newton, established the theory in the form in which we now know it.

120. Sidereal and Synodic Periods.—The *sidereal period* of a planet is the actual period of its revolution around the Sun. As seen from the Sun, a planet will again be in the same position relatively to the stars after one sidereal period.

The *synodic period* is the time between two successive conjunctions with the Sun, as seen from the Earth.

If E , P denote the sidereal periods of the Earth and the planet respectively and S the planet's synodic period, then, since the planet and the Earth move around the Sun in the same direction, the angular rate of motion of the planet

relatively to the Earth is the difference between the angular rates of motion of the planet and Earth respectively relatively to the Sun. Hence

$$\frac{1}{S} = \frac{1}{P} - \frac{1}{E} \text{ or } \frac{1}{E} - \frac{1}{P}$$

according as the planet is nearer to or farther from the Sun than the Earth. The approximate sidereal and synodic periods of the several planets are as follows :—

Planet.	Sidereal Period.	Synodic Period.
Mercury	88 days	116 days
Venus	225 „	584 „
Earth	365 „	—
Mars	687 „	780 „
Jupiter	12 years	399 „
Saturn	30 „	378 „
Uranus	84 „	370 „
Neptune	165 „	368 „

121. Empirical Laws connecting the Relative Distances of Planets from the Sun.—A curious empirical relationship between the distances of the planets from the Sun was formulated by Bode in 1772 and is known as Bode's Law. To the numbers 0, 3, 6, 12, 24, 48, etc., are added the number 4. The resulting series of numbers divided by 10 express approximately the mean distances of the planets from the Sun in terms of the Earth's distance as unity. The numbers obtained by this rule are

0.4, 0.7, 1.0, 1.6, 2.8, 5.2, 10.0, 19.6, 38.8.

The following are the approximate mean distances of the planets which were known at the time the law was formulated : Mercury, 0.39 ; Venus, 0.72 ; Earth, 1.00 ; Mars, 1.52 ; Jupiter, 5.20 ; Saturn, 9.54. It will be seen that there was a gap at 2.8 and the series ended with Saturn. The gap between Mars and Jupiter can be regarded as filled by the discovery of the belt of asteroids, with mean distance about 2.65. The discovery of Uranus, mean distance 19.18, continued the series, and it is of interest to note that when Adams and

Leverrier were computing the position of the hypothetical planet which would account for the perturbations of Uranus, they provisionally assigned to it the distance required by Bode's law. Their investigations led to the discovery of Neptune, but later observations showed that this planet departs more widely than any other from the law, its mean distance being only 30.05. The law is, nevertheless, a convenient aid for remembering the approximate relative distances of the planets.

Bode's law can be represented in the form $a + bc^n$ by putting $n = -\infty$ for Mercury, $n = 0$ for Venus, $n = 1$ for the Earth, etc., with $a = 0.4$, $b = 0.3$, and $c = 2$. Other empirical laws of this type have been formulated, values for a , b , c being chosen so as to represent some of the distances as closely as possible. Thus, Bédot adopts $a = 0.28$, $b = 1/214.45$, and $c = 1.883$. Such laws secure a better general representation than Bode's law, but are artificial and have no theoretical foundation.

122. Elements of a Planet's Orbit.—In order to define the position in space of the orbit of a planet and the position of the planet in its orbit, seven quantities are necessary. These quantities, with their usual designations, are as follows :

1. The semi-major axis of the orbit, a .
2. The eccentricity of the orbit, e .
3. The inclination of the plane of the orbit to the ecliptic, i .
4. The longitude of the ascending node, ω .
5. The longitude of perihelion, $\tilde{\omega}$.
6. The epoch, T .
7. The period, P , or mean motion, n .

Of these quantities, the first and second define the size and shape of the orbit, the third and fourth define the plane of the orbit, the fifth defines the direction of the major axis in the plane, and the sixth and seventh are used to define the position of the planet in its orbit at any time.

The seven elements are represented in Fig. 78. S represents the position of the Sun, ASA' the major axis of the orbit, A being perihelion and A' aphelion. $ENN'E'$ is the plane of the ecliptic and $PNN'P'$ that of the planet's orbit. NN' is

therefore the line of nodes. φ , \simeq , points in the ecliptic plane, represent the position of the vernal and autumnal equinoxes. If C is the midpoint of AA' , then $CA = CA' = a$, the semi-major axis of the orbit which is usually expressed in terms of the mean distance of the Earth from the Sun as a unit (astronomical unit).

CS/CA is equal to the eccentricity of the orbit. The inclination, i , is given by the angle PNE , the angle between the plane of the orbit and the ecliptic. The longitude of the ascending node, \simeq , is the angle φSN , the direction of motion of the planet in its orbit being in the direction of the arrow-head. The so-called longitude of perihelion, $\tilde{\omega}$, is the sum of two angles, one— \simeq —measured in

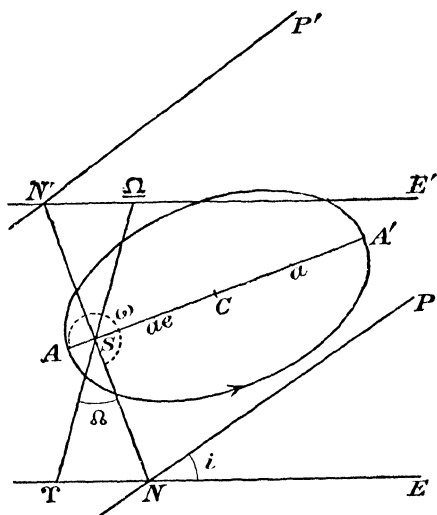

FIG. 78.—The Elements of a Planet's Orbit.

the plane of the ecliptic, and the other, ω or NSA (taken in the sense shown) measured in the plane of the orbit; it is not, strictly speaking, a longitude. The mean motion or period, together with the epoch, i.e. the position of the planet at some specified time, are sufficient to determine its position in the orbit at any subsequent time, the shape and size of the orbit being given. It will be seen that \simeq defines the line of nodes; i then defines the plane of the orbit; ω defines the position of the axis major; a and e then give the shape and size of the orbit.

123. **Stability of the Solar System.**—The elements of any planetary orbit would be absolutely constant if the Sun, assumed spherical, and the planet alone constituted the solar system, except for the slight shifting of the perihelion required by Einstein's theory of gravitation (p. 264). The mutual attraction of the planets, however,

introduce small disturbing forces which produce slight changes in their orbits. Is it possible that these slight changes may in the course of time so add up that the orbits of the planets may be gradually modified to such an extent that their physical conditions may be entirely altered or the system itself even destroyed? That branch of astronomy which seeks to determine the motions of the planets under the forces of gravitation and to answer this question is called "celestial mechanics." Although the problem of determining the subsequent motion of three bodies started in any manner under the action of their mutual gravitation is not capable of solution in general, it is possible to give an answer to the above question. This possibility is due to the preponderating mass of the Sun in the solar system, which ensures that the planetary orbits must be very nearly ellipses. The mathematical investigations of Laplace, Lagrange, and others have shown that the major axes of the orbits can undergo only slight changes and that these are of a periodic nature, so that the average values taken over a sufficiently long period of time will show no change. It follows, from Kepler's third law, that the periods can show only small periodic changes. The eccentricities and inclinations of the orbits relative to a fixed plane may show greater variations in the course of thousands of years, but these variations cannot exceed certain definite limits. As the fixed plane of reference for the inclinations, the ecliptic at a certain epoch may be chosen. This is not, however, a natural plane of reference, being connected with the orbit of the Earth and not being therefore absolutely fixed. Laplace showed that there was a certain plane the position of which remains absolutely unchanged by any mutual action between the planets; this plane is called the *invariable plane* and is defined by the following condition: If the radius vector from the Sun to each planet is projected upon this plane and each planet's mass multiplied by the area described in unit time by this projected radius vector, then the sum of the products so obtained will be a maximum. The inclination of the ecliptic to the invariable plane is about 2° . The limits between which the eccentricities and inclinations of the planetary orbits must lie are given in the subjoined table:—

	Eccentricity.			Inclination relative to invariable Plane.	
	Min.	Max.	Present Value.	Min.	Max.
Mercury	0.1215	0.2317	0.2056	4 44	9 11
Venus0000	.0706	.0068	0 0	3 16
Earth0000	.0694	.0167	0 0	3 6
Mars0185	.1397	.0933	0 0	5 56
Jupiter0255	.0608	.0483	0 14	0 29
Saturn0124	.0843	.0559	0 47	1 1
Uranus0118	.0780	.0463	0 54	1 7
Neptune0056	.0145	.0090	0 34	0 47

Since the major axes and periods in the mean remain constant and since the eccentricities and inclinations vary only within narrow limits, it follows that the solar system is stable in so far as the effect of the mutual attractions of its component parts is concerned.

124. **The Determination of a Planetary Orbit.**—A knowledge of the elements of a planetary orbit and of the manner in which they vary with time enables the position of the planet at any future date to be predicted. For this purpose, long-continued observations are necessary so that the theory can be worked out with a high degree of approximation. For some purposes it is necessary quickly to determine an approximate orbit; for instance, a minor planet may be discovered, and after a few observations have been secured may be lost in the Sun's rays at conjunction. If these observations suffice to determine the orbit, it becomes possible to identify the planet again when it emerges from the Sun's rays. For such purposes the assumption is made that the orbit is accurately an ellipse, with the Sun in one of the foci, and the calculations follow a process invented by Gauss, or a modification of his method. There are six elements to determine, since of the seven elements which are necessary to define an orbit in space, the mean motion or period and the mean distance are connected by Kepler's third law. It is therefore necessary to have six observational data at known times in order to derive the orbit.

For instance, if for a given instant of time, the three co-ordinates and velocity components of the body relative to three fixed planes through the Sun were known, the orbit could be determined; or, again, if the three co-ordinates were known for two given instants. Actual observations provide positions relative to the Earth, and the most convenient form in which the necessary data can therefore be supplied is to give the values of the right ascensions and declinations of the body at three instants. Gauss's method is based on these data; by a mathematical process the geocentric positions at the three times are first derived from the observed right ascensions and declinations. The heliocentric positions are then deduced, after which the actual determination of the elements is straightforward. For the details of the process, reference should be made to a treatise on celestial mechanics. Using Gauss's method, three observations of the modern degree of accuracy, separated only by a week or two, will give an orbit sufficiently accurate for the body to be found again after the lapse of a considerable time. Such a preliminary orbit having been found, it can subsequently be corrected, if necessary, by differential methods based upon further observations. For predicting future positions, allowance must be made for the perturbing actions of other planets.

125. Determination of Diameters of Planets.—There are two methods of determining the angular diameter of a planet.

(i) A filar micrometer may be used, with which may be measured the actual linear dimensions of the image produced in the focal plane of the telescope; the value so obtained, divided by the focal length of the instrument, gives the angular diameter in circular measure. The wire micrometer is generally used, the wires being placed tangentially to the two limbs of the planet and then crossed over and the observation repeated. The observation is subject to an error due to *irradiation*, which is physiological in nature. A bright object appears to the eye somewhat larger than it actually is; although the error may be reduced by employing a large instrument and a bright field of view, it is very difficult to ensure that it is entirely eliminated. It is therefore better to employ a double-image micrometer, which forms two images of the planet whose

distance apart can be varied. The two images are adjusted so that they are tangential to one another, and the irradiation error in making this observation is less than in setting a dark wire tangential to a bright limb.

(ii) A more accurate method is that devised by Michelson, which is entirely free from irradiation errors. If two parallel narrow slits are placed in front of the object glass of the telescope, which is set to view the planet, then the image produced in the focal plane consists, in general, of a series of short parallel alternately light and dark interference fringes, extending in a direction at right angles to the length of the slits. There is thus a gradation of light in the field. If the distance apart of the slits is varied, this gradation changes, and if the amount of light thrown into the bright fringes is increased and that into the dark fringes decreased their visibility becomes plainer. There are, however, certain distances apart of the slits for which the gradation entirely vanishes, the light and dark fringes then becoming of equal brightness and therefore ceasing to be visible. The distances apart of the slits for which this happens are given by :—

$$d = (1.22, 2.24, \dots) \lambda/a$$

where λ is the mean wave-length of the light (which may be taken as 5,500 angstrom units or 5.5×10^{-5} cms.) and a is the angular diameter of the object viewed. The determination of the least distance apart of the slits for which the visibility of the fringes vanishes enables the angular diameter of the body to be determined from the relationship $\alpha = 1.22\lambda/d$. This observation can be made very accurately and has the advantages not only of being free from irradiation error but also of being relatively independent of atmospheric definition.

The angular diameter may be converted into linear diameter on multiplying by the distance of the planet from the Earth. The distances of the planets can all be deduced by Kepler's third law when the distance of the Earth from the Sun has been determined and the planet's period has been measured. The methods by which this distance can be found have already been described in § 63.

Synodic period, i.e. the interval between two successive opposi-

126. Determination of the Period of a Planet.—The most accurate method of determining a planet's period is to find its

tions or conjunctions of the planet. In practice, of course, the times of the oppositions, i.e. the moments when the longitudes of the Sun and planet differ by 180° , must be observed. At opposition, a planet will cross the meridian near midnight. The procedure involves the determination of the right ascension and declination of the planet at meridian transit for several days before and after opposition, the Sun also being observed at apparent noon. By interpolation from the latter observations the longitudes of the Sun corresponding to the times of the planetary observations can be obtained. The planetary observations give the longitudes of the planet at the same instant. The differences of longitude between Sun and planet are tabulated with the corresponding times, and, by another interpolation, the exact time of opposition, corresponding to a longitude difference of 180° , can be derived.

The planetary orbits not being exactly circular, the mean synodic period is not thus obtained. By extending the observations over a sufficient number of oppositions, however, the mean period can be obtained with any desired degree of accuracy. Once the synodic period is known, the true sidereal period is obtained from the relationship, $1/P = 1/E - 1/S$ (see § 120).

127. Determination of the Mass of a Planet.—If a planet has a satellite, its mass can readily be determined as follows:—If M is the mass of the planet, m that of the satellite, a, a' the radii of the orbits of the planet and its satellite respectively, T, T' their periods, S the mass of the Sun, and G the gravitational constant, the accelerating force acting on the satellite is given by $G(M + m)/a'^2$. But the acceleration in a circular orbit is given by the square of the angular velocity multiplied by the radius or $(2\pi/T')^2 \times a'$. Hence

$$G \frac{(M + m)}{a'^2} = 4\pi^2 \frac{a'}{T'^2}$$

Similarly, considering the motion of the planet around the Sun,

$$G \frac{(S + M)}{a^2} = 4\pi^2 \frac{a}{T^2}$$

whence

$$\frac{M + m}{S + M} = \left(\frac{a'}{a}\right)^3 \left(\frac{T}{T'}\right)^2$$

The relative distances and the periods must therefore first be determined. In general, the mass of the satellite can be neglected compared with that of the planet and the mass of the planet can be neglected compared with that of the Sun, so that we have simply,

$$\frac{M}{S} = \left(\frac{a'}{a}\right)^3 \left(\frac{T}{T'}\right)^2$$

This determines the mass of the planet in terms of that of the Sun, and we have previously explained how the masses of the Earth and Sun can be determined. Therefore, the mass of any planet possessing a satellite can be found.

In the case of those planets which do not possess a satellite, the determination of the mass is more indirect and difficult. It must be based upon the magnitude of the perturbation produced by the planet on a neighbouring planet when the two planets are near their distance of closest approach: knowing the paths of the two planets, it is possible to calculate the mass which would produce the observed deviations from elliptic motion. Thus Venus perturbs the Earth, and from the magnitude of the perturbation the mass of Venus may be deduced. So also Mercury perturbs Venus, and this perturbation enables the mass of Mercury to be deduced.

The methods by which the masses and linear diameters of the planets may be determined have now been detailed. By dividing the mass by the volume, the actual density of the planet may be obtained. Or, if mass and radius are expressed in terms of those of the Earth, the density in terms of the density of the Earth as unity can be obtained from the simple formula:—

$$d = M/R^3$$

For instance, Jupiter's mass derived from satellite observations is about 316 times that of the Earth, and its radius is about 11 times the Earth's radius. Hence its density is $316/11^3$, or about 0.24 of that of the Earth. Assuming for the value of the Earth's mean density 5.53, the density of Jupiter is found to be about 1.33 times that of water.

The value of the gravitational attraction at the surface of a planet compared with that at the surface of the Earth is of importance in forming a conception of the physical con-

ditions on the planet's surface. Expressing the mass and radius in terms of those of the Earth, the surface gravity is M/R^2 or M/R^3 multiplied by R , i.e. equal to the planet's density multiplied by its radius, both quantities being expressed in terms of the corresponding quantities for the Earth. At the surface of Jupiter, the force of gravity would therefore be 11×0.24 , or 2.64. A body of given mass would therefore weigh 2.64 times as much at the surface of Jupiter as at the surface of the Earth.

128. Motion in a Resisting Medium.—It is of interest to consider in what way the motion of a body moving under gravitational attraction would be affected by the presence of a resisting medium. It will suffice for an explanation of the principles to consider only the case of a circular orbit.

If v , w are respectively the linear and angular velocities when the radius of the orbit is r , and M denotes the mass of the attracting body,

$$rw^2 = \frac{GM}{r^2}$$

$$\text{and } v = rw = \sqrt{GM/r}$$

so that, for equilibrium, the linear velocity must increase as the radius of the orbit decreases.

The resistance of the medium may be supposed small, and proportional to the square of the velocity, say kv^2 . Then, in one revolution, the work done by the body against the resistance is $2\pi rkv^2 = 2\pi kGM$. This must be performed at the expense of its kinetic and potential energies.

The attracting force acting on the body is GMm/r^2 , and if the body moves outwards a distance Δr , the decrease in potential energy is consequently $-(GMm/r^2)\Delta r$. Also since the kinetic energy is $\frac{1}{2}mv^2$, when the velocity increases by Δv , the diminution in the kinetic energy is $-mv \cdot \Delta v$. Hence we must have, by the principle of conservation of energy,

$$2\pi kGM = -\frac{GMm}{r^2}\Delta r - mv\Delta v$$

But since $v^2 = GM/r$, $v\Delta v = -\frac{1}{2}GM/r^2 \cdot \Delta r$
 so that $\Delta r = -4\pi kr^2/m$
 and $v\Delta v = +2\pi kGM/m$.

It follows therefore that the effect of the resisting medium is to decrease the radius of the orbit and to increase the linear velocity and consequently to decrease the period. The increase in the velocity appears at first sight to be a paradoxical result, but it is in reality a consequence of the decrease in the radius of the orbit.

129. Velocity at any point under Gravitational Attraction.—It can be shown by dynamics that when any body is moving under the action of an attractive central force of amount μ/r^2 , its orbit must always be a “conic section,” i.e. a curve which may be obtained by cutting a right circular cone. Such curves are the circle, ellipse, parabola, and hyperbola, with, as a special case, a straight line. The planets afford examples of the elliptic motion; certain comets, examples of the parabolic and possibly of the hyperbolic motion.

If a is the semi-axis major of the orbit, it can be shown that the velocity at any distance r is given by

$$V^2 = \mu \left(\frac{2}{r} - \frac{1}{a} \right)$$

The velocity is greatest when r is least, i.e. at perihelion, and least when r is greatest, i.e. at aphelion. In the case of an ellipse $\frac{1}{a}$ is positive, for a parabola it is zero, and for a hyperbola it is negative.

If a body is moving in a straight line towards the attracting force, the velocity which it acquires in moving from rest at a distance s to a distance r is given by $v^2 = 2\mu(1/r - 1/s)$; if, therefore, it starts from rest at an infinite distance, the velocity acquired in falling to a distance r under the action of the attracting force will be $v = \sqrt{2\mu/r}$. If, on the other hand, the body is moving in a parabola, its velocity at distance r will also be $\sqrt{2\mu/r}$ (putting $\frac{1}{a} = 0$). Hence this velocity is called the “velocity from infinity,” or the “parabolic velocity.” The parabolic velocity due to the attraction of the Sun is, at the mean distance of the Earth from the Sun, equal to 26.2 miles per sec. At this distance, a body projected in any

direction with this velocity would describe a parabolic orbit : if projected with a greater velocity, the orbit would be hyperbolic, and if with a lesser velocity, it would be elliptic.

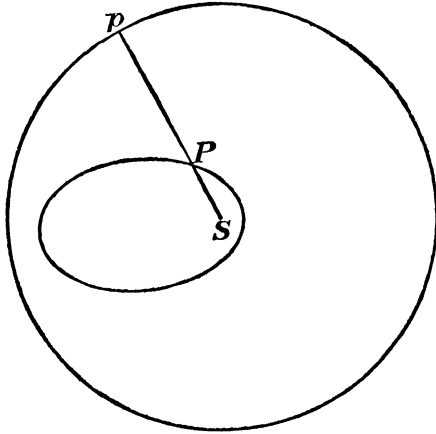

FIG. 79.—Velocity in an Elliptic Orbit.

From the above considerations, the following simple method of representing the velocity of a body at any point in an elliptic orbit may be derived. If about S (Fig. 79) a circle be described of radius equal to the major axis of the elliptic orbit ($2a$), then the velocity of the planet at any point P is equal to that which it would have acquired by falling from rest at the point p , in which SP produced meets the circle, to the point P . For the velocity so acquired would be given by

$$v^2 = 2\mu \left(\frac{1}{SP} - \frac{1}{Sp} \right) = 2\mu \left(\frac{1}{r} - \frac{1}{2a} \right) = \mu \left(\frac{2}{r} - \frac{1}{a} \right)$$

which is the actual velocity at the point P of the orbit.

The parabolic velocity at the surface of the Earth, due to the Earth's attraction, is 6.94 miles per second. A body projected from the Earth with a velocity equal to or greater than this would describe a parabolic or hyperbolic orbit (neglecting the resistance of the Earth's atmosphere) and would not return. Other parabolic velocities in miles per second are : for the Sun, 383 ; Moon, 1.5 ; Mercury, 2.2 ; Venus, 6.6 ; Mars, 1.5 ; Jupiter, 37 ; Saturn, 22 ; Uranus, 13 ; Neptune, 14.

130. **Statistics of Planets.**—The following table gives, for reference purposes, the following statistics for planets: the period, semi-axis major (in terms of that of the Earth as unity), eccentricity, inclination to ecliptic, mean daily motion and mass in terms of that of the Sun.

Planet.	Period.	Semi-Axis Major.	Eccentricity.	Inclination to Ecliptic.	Mean Daily Motion.	Reciprocal of Mass (Sun = 1)
	d.			° ′	"	
Mercury . . .	87·97	0·387	·2056	7 0	14732·4	9,700,000
Venus . . .	224·70	0·723	·0068	3 24	5767·7	408,000
Earth . . .	365·26	1·000	·0167	0 0	3548·2	333,432
Mars . . .	686·98	1·524	·0933	1 51	1886·5	3,093,500
Jupiter . . .	4332·59	5·203	·0483	1 18	299·1	1047·36
Saturn . . .	10759·23	9·539	·0559	2 30	120·5	3501·6
Uranus . . .	30688·45	19·191	·0471	0 46	42·2	22,869
Neptune . . .	60181·3	30·071	·0085	1 47	21·5	19,314

CHAPTER X

THE PLANETS

131. **Mercury.**—As we have seen in the preceding chapter, the angular distances from the Sun of the two planets, Mercury and Venus, whose orbits lie within that of the Earth, can never exceed a certain value. This angle is attained when the planet reaches greatest elongation. Owing to the eccentricity of their orbits, the angle of greatest elongation is not constant, but in the mean it equals 23° for Mercury and 46° for Venus. These planets can therefore be observed by eye only in the early evening after sunset or in the morning shortly before sunrise, as they rise and set within a comparatively short period of the Sun's rising and setting. Owing to their great brightness, however, it is sometimes possible to observe them with a telescope in broad daylight. The popular designation, Evening Star or Morning Star, is used to denote whichever of these planets is visible in the western sky shortly after sunset or in the eastern sky shortly before sunrise.

Mercury is relatively infrequently seen with the naked eye on account of its small angle of greatest elongation. In high latitudes it is more difficult to observe than at places nearer the equator, as its maximum altitude for places in high latitudes is smaller owing to the smaller angle of inclination of the ecliptic to the horizon. Under favourable conditions, it is possible to observe the planet for about two weeks at each elongation; in the northern hemisphere it is best seen in the evening at eastern elongations in March or April. Notwithstanding the difficulty of observation, Mercury has been known from very early ages and no record of its discovery exists. By the ancients, it was given different names according as it appeared as a morning or as an evening star, so that

for some time it was not recognized as the same body in the two cases. Thus, the Greeks called it Mercury when seen as an evening star and Apollo when seen as a morning star.

The mean distance of Mercury from the Sun is 36 million miles. The eccentricity of its orbit is larger than that of any other planet (apart from certain asteroids), having the value 0.2056. Its actual distance from the Sun therefore ranges from $28\frac{1}{2}$ to $43\frac{1}{2}$ million miles, with a corresponding range in orbital velocity from 35 miles per second at perihelion to 23 miles per second at aphelion. The inclination of the orbit to the ecliptic is about 7° .

The sidereal period of Mercury (the planet's "year") is equal to 88 days. The synodic period is 116 days. Greatest elongation occurs about 22 days before and after inferior conjunction, and therefore about 36 days before and after superior conjunction.

The apparent diameter of Mercury, as obtained by micrometric observations, varies from about 5" to 13" according to its distance. The most reliable measures correspond to a linear diameter of about 2,950 miles, only slightly greater than one-third of the Earth's diameter. There is no reliable evidence of any flattening at the poles. Owing to the great brightness of the planet, and its small angular distance from the Sun, the diameter is not easy to measure; the most reliable observations are those obtained during a transit across the Sun's disc. The surface area of Mercury is only about one-seventh that of the Earth and its volume about one-nineteenth part.

Mercury has no satellite, and this makes its mass difficult to determine. The method of perturbations is the only one available, but as the planet's mass is small and it is near the Sun, its disturbing effects on the other planets are not large. The uncertainty attaching to its mass determination is therefore large. The most probable value is $1/9,700,000$ of the Sun's mass or $1/29$ of the Earth's. This value corresponds to a density of rather more than $6/10$ ths that of the Earth and a surface gravity of about 0.24.

132. Telescopic Appearance and Rotation Period.—Mercury, seen in the telescope, shows phases similar to those of the Moon. At inferior conjunction, when the planet is

nearest to the Earth, the dark side is towards us. Between inferior conjunction and greatest elongations, it shows a crescent phase. At greatest elongations, it appears practically like a half-moon. Between greatest elongations and superior conjunction, it is gibbous (i.e. more than half-phase), whilst at superior conjunction the illuminated surface is towards us, but the apparent diameter is then least.

There are no well-defined markings on the surface of Mercury. Such markings as can be perceived are of interest mainly for the information which their apparent motion may give about the period of rotation of the planet. In this way Schröter, a contemporary of Herschel, announced that the rotation period was 24 hours 5 minutes. Later, Schiaparelli contradicted this result: he stated that the surface markings showed no apparent motion in the course of several hours, so that the period must be much longer than found by Schröter. Schiaparelli concluded that the period was 88 days, in other words, that the planet in its orbital motion round the Sun always turns the same face towards it, and so behaves to the Sun as the Moon does to the Earth. This value for the rotation period seems to be more probable than the shorter period, but it has remained up to the present unconfirmed. Such surface markings as are seen on Mercury are very faint, diffuse, and ill-defined. Their position cannot be accurately determined and it is doubtful whether the markings can be regarded as in any sense permanent. The true value of the rotation period of Mercury must therefore be regarded as an open question.

133. Physical Nature and Atmosphere.—If Mercury does turn the same surface always towards the Sun, its physical conditions might with some plausibility be expected to be not dissimilar to those existing on the Moon, which is characterized by the absence of air and water and by a rough, irregular surface. Some information on this point is given by the planet's *albedo*, i.e. the fraction of the incident sunlight which is reflected back by the body. The mean value of the albedo for the Moon is about 0.13, but varies with the phase: near new Moon the amount of reflected light is less than the theoretical value for a smooth sphere, this being due to the

roughness of the Moon's surface. The mean albedo found for Mercury is about 0.14 and shows the same variation with phase as that of the Moon: this supports the hypothesis that the surface conditions of the two bodies are very similar.

The low value of the albedo is strong evidence that the planet is not cloud-covered, and it is plausible to assume that, if it has an atmosphere, the density is very much less than that of the Earth's. This assumption is supported by the appearance of Mercury when it enters the limb of the Sun at a time of transit: in the case of Venus, a bright ring is then seen round the planet due to refraction in its atmosphere, but with Mercury no such ring is seen. Spectroscopic observations of Mercury also support the same view: there is no marked difference when examined in the spectroscope between the light reaching us directly from the Sun and that reaching us after reflection from Mercury, making the presence of a dense atmosphere very improbable.

Such scanty observations as are available, supported by various lines of indirect reasoning, lead therefore to the conclusion that Mercury is probably similar as regards physical conditions to the Moon, with a rough surface and little or no atmosphere. The one side is turned always to the Sun, the other side always away from it. Its density is relatively high and not greatly different from that of the Moon.

134. Venus.—The next planet in order from the Sun is Venus, the brightest of all the planets. Although so bright and easily observable, our knowledge of the conditions on the planet are hardly more complete than in the case of Mercury. The great brightness of the planet is, in fact, in some ways a hindrance to observation.

The mean distance of Venus from the Sun is about 67 million miles, and as the eccentricity of the orbit is only 0.007, the least in the solar system, the greatest and least distances from the Sun do not differ by as much as 1 million miles. The sidereal period of Venus is 225 days, and the synodic period is 584 days. Its orbital velocity is 22 miles per second. Greatest elongation occurs about 71 or 72 days before or after inferior conjunction. The inclination of its orbit is only $3^{\circ} 24'$.

The distance of Venus from the Earth varies from 26 million

miles at inferior conjunction to 160 million at superior conjunction. Its apparent angular diameter correspondingly varies from $67''$ to $11''$. Its real diameter is 7,700 miles, and the size of Venus is not therefore greatly different from that of the Earth.

As Venus has no satellite, the mass must be found by the method of perturbations. This method gives a more reliable result in the case of Venus than in that of Mercury. The most probable value of the mass is $1/403,490$ that of the Sun, or about 0.826 of that of the Earth. The density and superficial gravity in terms of those of the Earth are respectively 0.94 and 0.90. The mass, density, and surface gravity of Venus are therefore comparable with those of the Earth.

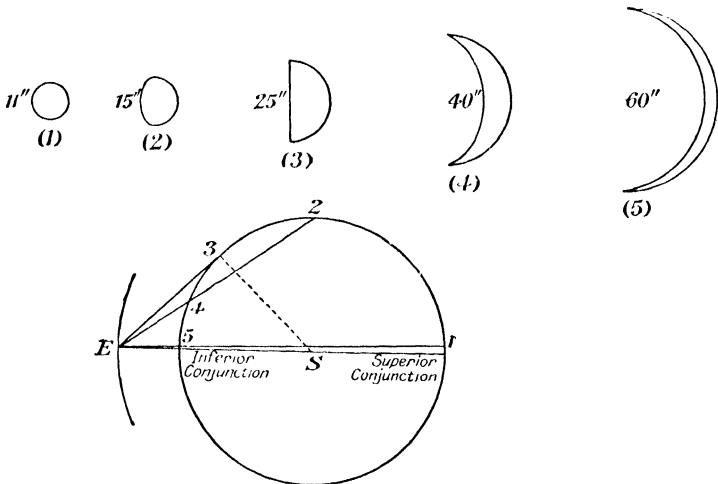

FIG. 80.—The Telescopic Appearances of Venus.

135. Phases and Brightness of Venus.—Venus exhibits phases similar to those of the Moon and Mercury. They are more easily observed than in the case of Mercury on account of the larger angular diameter of Venus; a telescope of very moderate power will reveal them easily. When showing the crescent phase, the planet appears much larger than when seen full at superior conjunction, on account of the great difference in the distance from the Earth in the two cases. The phases and relative sizes of Venus in different positions are shown in Fig. 80.

It is of interest to note that according to the theory of Ptolemy, Venus could never be seen larger than the half-moon shape. In Fig. 81, S , V , E , represent the relative positions of the Sun, Venus, and the Earth according to Ptolemy. The centre of the epicycle of Venus is on the deferent of Venus and also on the line joining the Sun to the Earth. It is clear from the diagram that the angle SVE could never be so small as a right angle since the radius of the epicycle of Venus is small compared with the distances VS and VE .

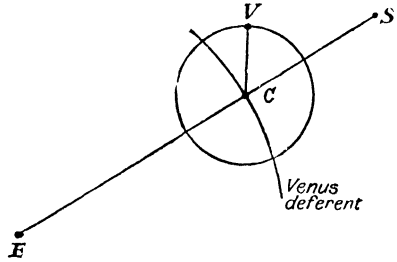

FIG. 81.—Ptolemy's Theory of Venus.

But it is only when this angle becomes less than a right angle that the planet can appear more than half illuminated. The discovery of the gibbous phase of Venus by Galileo was one of the early fruits of his application of the telescope to astronomical observation and provided a strong argument for the theory of Copernicus and against that of Ptolemy.

The variations of brightness of Venus are due partly to the changes in the phase of the planet and partly to the changes in the distance from the Earth. Since the full-moon phase occurs when the planet is at its greatest distance from the Earth, the two effects tend to compensate one another, and Venus does not show the wide range in brightness which the changes in its distance alone would require. It can be shown by a simple mathematical investigation that the greatest brightness occurs about 36 days before or after inferior conjunction. The phase then corresponds to that of the Moon when about 5 days old. Venus is then six or seven times as bright as the brightest fixed star, Sirius, and can be easily seen with the naked eye in broad daylight, if one knows where to look for it.

136. Telescopic Appearance and Rotation Period.—

Owing to its great brightness, Venus can best be observed telescopically in the twilight, just after sunset or just before

dawn. She does not show any conspicuous or well-defined surface markings. When in the crescent phase, ill-defined darkish shadings can be seen near the terminator. These markings possess no distinct outline and may be mere atmospheric objects and not true surface markings. Lowell claimed to have seen more definite markings, but the observations are so difficult that it is doubtful whether they can be substantiated.

The absence of well-defined markings makes the determination of the rotation period of Venus difficult, and the actual period is still a subject of dispute. Cassini found a period of 23 h. 15 m., and Schröter found 23 h. 21 m. Other investigators have asserted that the period is much longer than this. Schiaparelli concluded that it was 225 days, in which case the planet would always turn the same face towards the Sun. Although several series of observations seem to support the shorter period found by Cassini, yet these same series give for the inclination of the axis of Venus to its orbital plane values which differ by more than 20° . It does not seem possible that visual observations will settle the question: an observer with great acuity of vision, possessed of excellent judgment, and making observations under the most favourable atmospheric conditions, would be necessary, but these are conditions which it is difficult to combine, and even if obtainable success could not be guaranteed.

The most promising method of attacking the problem is the spectroscopic method, using Doppler's principle, as explained in connection with the determination of the period of rotation of the Sun. As applied in the case of the Sun, the method consists in photographing the spectra of the light from the eastern and western limbs of near the equator and measuring the relative displacement of the lines. As a result of rotation one limb moves towards the observer and the other away from him as compared with the centre. In spite of the much smaller relative displacement to be expected in the case of Venus than in that of the Sun, the method would probably give accurate results, if it could be applied in this way. When Venus is near the Earth, however, one limb is always in darkness, and when near superior conjunction the image is small and errors due to irregular guiding become important. It is not surprising, therefore, that the results

furnished by the spectroscopic method are discordant, as it cannot be used differentially. Belopolsky found a rotation period of 12 hours ; Lowell and Slipher 30 days, the spectroscopic method being used in each case. The true period remains unknown, and the problem is one of the most difficult astronomical problems awaiting solution.

137. Physical Conditions.—The albedo of Venus has the high value of 0.76, which is about equal to the reflecting power of freshly fallen snow. As few, if any, rocks or soils have so high a reflecting power, the value would seem to indicate that the planet is mostly or entirely cloud-covered.

This conclusion is supported from other considerations. When Venus is entering the Sun's disc at a transit, its black disc is seen surrounded by a bright ring of light which must be due to refraction by the atmosphere of Venus. From observations made at transits, it has been concluded that the depth of the atmosphere must be at least 55 miles. When Venus is seen in its early crescent phase, the horns of the crescent extend appreciably beyond their geometrical position and sometimes a thin line of light, completing the whole circumference of the planet, may be observed. This also is an effect of refraction.

Such definite knowledge as we possess of the nature of the atmosphere of Venus is negative in character. St. John has photographed the spectrum of Venus when its velocity relative to the Earth is a maximum. If water-vapour or oxygen are present in the planet's atmosphere, there should be a double series of absorption lines in its spectrum, due to the absorption in the planet's atmosphere and the Earth's atmosphere respectively, the separation being the relative Doppler displacement. No lines due to either substance in the atmosphere of Venus were found, however. It therefore seems probable that oxygen and water-vapour are not present, at any rate in the outer layers of the atmosphere of Venus. This suggests the question: of what is its atmosphere composed ?

It has been asserted by many observers, and denied by many others, that at times a faint illumination of the dark portion of the planet's surface may be seen, akin to the

phenomenon of the old Moon in the arms of the new. Since Venus has no satellite, such illumination—if not a subjective phenomenon—must either originate on the planet's surface or be due to reflection of light by the Earth. The study of Earth-shine on the Moon shows that the Earth's surface has a high albedo, so that, seen from Venus, the Earth under favourable conditions would appear several times as bright as Venus at its brightest appears to us. It is, nevertheless, doubtful whether the reflected light from the Earth is capable of explaining the phenomenon, more particularly as it is stated to have been observed even in daylight. If not explicable in this way, the phenomenon may be of an electrical nature and possibly comparable with the aurora.

138. **Mars.**—The planets whose orbits lie outside that of the Earth are much more suitably situated for observation than Venus and Mercury. They are seen fully illuminated by the Sun when at their nearest to the Earth, instead of when at their greatest distance. They may be observed at certain seasons throughout the night, since their elongations may have all values from 0 to 180° . Their phase changes are also much less important than for the two inner planets.

The nearest to the Earth of the outer planets is Mars, which has been known from remote antiquity. Its mean distance from the Sun is 141·5 million miles, and the eccentricity of its orbit is 0·0933, which, after Mercury, is the largest value for any of the major planets. In consequence of this eccentricity, its distance from the Sun varies by about 26 million miles. The inclination of its orbit to the ecliptic is small, $1^\circ 51'$. The sidereal period is 687 days and the synodic period is 780 days. The latter is the longest in the solar system. The planet retrogrades during 70 days of these 780, through an arc of about 18° .

The average distance of Mars from the Earth at opposition is 48·5 million miles. The actual distance depends upon whether the opposition occurs near the planet's perihelion or aphelion. In the former case it is only 35 million miles; in the latter it is 61 million. At conjunction, the average distance from the Earth is 234·5 million miles.

The apparent diameter of the planet varies between $3''\cdot6$

and $25''.0$, the latter value being obtained at a favourable opposition. Its true diameter is about 4,200 miles, so that its surface is rather more than one-quarter and its volume about one-seventh those of the Earth. Its mass can be determined with accuracy, as it possesses satellites. Compared with the Sun it is $1/3,093,500$, or 0.108 of that of the Earth. This figure gives for its density 0.72 and surface gravity 0.38 in terms of the corresponding quantities for the Earth.

Since the orbit of Mars is outside that of the Earth, the planet cannot come between the Sun and the Earth and therefore does not show any crescent phases. Both at opposition and superior conjunction, the whole of the illuminated hemisphere is turned towards the Earth, but at quadrature a distinct gibbous phase may be seen, which corresponds to the appearance of the Moon when about three days from full.

It follows that the variation in brilliancy of the planet is much greater than is the case with Venus. At conjunction, Mars is about as bright as the pole star, but at opposition, owing to its relative nearness to the Earth, it is on the average about twenty-three times as bright. At a favourable opposition, it may be sixty times brighter than at conjunction. The difference in apparent brightness between favourable and unfavourable oppositions exceeds four to one. The favourable oppositions always occur in the latter part of August, as the Earth then passes through the line of apses of the orbit of Mars. The interval between consecutive favourable oppositions is 15 or 17 years. Fifteen years is somewhat longer than 7 synodic periods of Mars and 17 years is somewhat less than 8 synodic periods. The last favourable opposition was in 1907 and the next will occur in 1924.

139. Telescopic Appearance and Rotation Period.—The early telescopic observations of Mars in the seventeenth century revealed certain markings on the planet which altered their position from hour to hour. From a study of these markings, Cassini found for the period of rotation 24 h. 40 m. Later observations have enabled the period to be determined with very great accuracy: by comparing modern observations with old ones, an approximate knowledge of the period suffices to determine the exact number of revolutions in the interval

between the observations, and thence an accurate value of the period may be deduced. In this way a value of 24 h. 37 m. 22.6 s. has been determined. A comparison of the two drawings in Plate XII (*a*), the interval between which was 23 h. 15 m., illustrates the rotation of the planet.

The inclination of the planet's equator to its orbital plane is about 24.5° . This inclination may be deduced from observations of the surface markings, or, in particular, of the polar caps. It was noticed by the early observers, Huyghens, Cassini, and others, that around each pole of Mars was to be seen, at certain times, a white cap, which they compared with the regions of ice and snow at the two poles of the Earth. The size of these caps was found to vary and also the times when they could be observed. If opposition occurred near perihelion, the south-polar cap was turned towards the Earth; if near aphelion, the north-polar cap. Herschel first pointed out that the period of variation of the size of the polar caps is equal to the sidereal period of Mars and suggested that the decrease in size of, say, the northern cap, was due to the melting of ice and snow by the heat of the Sun in the planet's northern summer, and that when winter returned the cap increased in size as the water froze again. The polar caps are shown in the drawings of Mars (Plate XII (*a*)) and in the photographs (Plate XIII (*a*)).

Besides these polar caps, whose interpretation as formed of ice and snow can hardly be doubted, there are other markings visible on Mars whose nature is more controversial. The most noticeable features are patches of a bluish-grey or greenish shade which cover usually about three-eighths of the planet's surface and are found mainly in the southern hemisphere near the equator; there are also extensive regions of brownish or orange shades which occur mainly in the northern hemisphere and cover more than half the surface. There is a tendency to interpret these markings in terms of the physical conditions existing on our Earth and to consider the greyish regions as sheets of water and the brown regions as land, probably deserts of sand or rock. The names of various markings on Mars to be found on maps of the planet, such as Mare Tyrrhenum, Mare Sirenum, etc., must, however, not be interpreted literally, any more than similar names applied

to portions of the surface of the Moon. It is not improbable that future investigation will show that the names are in reality unsuitable. Most of the names by which the various formations on Mars are known were given by the Italian observer Schiaparelli, who from 1877 onwards made numerous observations of Mars. Favoured with exceptional eyesight and a good telescope, he added greatly to the existing knowledge of the various formations : the smallest markings were observed and measured micrometrically, enabling accurate maps of the Martian surface to be constructed.

In 1877 Schiaparelli discovered that the so-called continents were intersected by numerous straight greyish lines, which he interpreted as a network of channels for water intersecting the land ; these he designated by the Italian word *canali*. The nature of the canals has given rise to much speculation and controversy. For nine years, until 1886, only Schiaparelli could see them, but they were observed in that year by Perrotin and Thollon at the Nice Observatory and subsequently by many other observers, in particular by Lowell and Slipher at the Flagstaff Observatory. The careful observations of these observers, made under favourable atmospheric conditions, led them to assert that at times some of the canals became double ; that the so-called seas were also intersected by canals and are therefore probably not of an aqueous nature at all ; that at the intersections of the canals are small round dark spots which have been variously called *lakes* and *oases* ; and that as the polar caps melt the canals darken. On the other hand, other careful observers, such as Barnard, observing under favourable conditions, have failed to detect the canals, and photographs of Mars have not revealed the thin, sharp lines delineated by Lowell (*see* Plate XIII (*a*)). It is possible, therefore, that the canals are really subjective phenomena arising from the tendency of the eye to connect by straight lines faint markings which are visible only with difficulty. When observing at the limit of resolution of an optical instrument, it is well known that the observed details may not correspond with fact ; thus, for example, with a microscope, totally different structures of diatoms may be observed with objectives of differing perfection and resolving power. Whilst it would be unwise to make too definite an assertion, the balance of

probability seems to be in favour of the supposition that the canals are subjective. The appearance of Mars in the telescope may be judged from Plate XII (*a*), reproducing drawings by a skilled observer under good conditions.

Lowell built up a speculative theory of the canals which has not received general acceptance. He supposed that the polar caps are composed of ice and snow, which melt in summer, the water flowing towards the equator, through the canals, which he considers are artificial water-channels constructed by intelligent beings for irrigation purposes. On his theory, the dark regions formerly considered as seas are land covered with vegetation, whilst the ruddy portions are deserts. As the water flows along the channels, vegetation springs up along them, and these we observe as canals. Where the canals cross, oases are formed. This theory involves many difficulties: if intelligent beings are at work in the way suggested, it would be expected that they would construct the canals to follow the contours of the planet's surface instead of making them absolutely straight for thousands of miles. Also it is difficult to imagine that canals could be constructed to carry water from the melting north-polar cap well down into the southern hemisphere and from the south cap well into the northern hemisphere. There is the further difficulty that the rate of disappearance of the polar caps is such that it is difficult to believe that they can be thick masses of ice and snow: more probably they are thin deposits of snow or hoar-frost. The only portion of the theory which receives fairly general acceptance is the existence of seasonal changes on Mars which could reasonably be attributed as due to changes in vegetation.

140. Atmosphere and Temperature of Mars.—It is very probable that Mars possesses an atmosphere, though much less dense than that of our Earth. At times thin, whitish veils of cloud have been observed which appear to admit of no alternative explanation. The deposition and dissipation of the polar caps also point to the presence of an atmosphere. From the planet's low surface gravity it would be anticipated that the density of the atmosphere would be low. Spectroscopic observations confirm this: Campbell, in 1909, photographed the spectrum of Mars from the summit of Mount

Whitney (15,000 ft.), so reducing the effect of the absorption of the Earth's atmosphere. To estimate the residual amount of absorption, the spectrum of the Moon was obtained for comparison. These results enabled Campbell to conclude that at the surface of Mars the density of the atmosphere is not more than one-half that of the density of the Earth's atmosphere at the summit of Mount Everest, and that, in particular, the Martian atmosphere contains very little, if any, water-vapour. Incidentally, this observation provides a strong argument against the hypothesis that there is much water on Mars, and that the polar caps are composed of thick masses of ice or snow. The albedo of Mars is 0.22, which is higher than those of the Moon and Mercury, but much smaller than that of Venus: it is consistent with the existence of a rare atmosphere.

On the assumption that the heat received by Mars from the Sun is just equal to the amount which it radiates into space, it is possible to form some idea of the temperature of Mars: some uncertainty is introduced by our ignorance as to the effect of the atmosphere on Mars in regulating the day and night temperatures. The problem was carefully investigated by Poynting on the supposition that the planet rotates about an axis perpendicular to the plane of its orbit. Assuming, firstly, that the effect of the atmosphere would keep the temperature in any given latitude the same, day and night, he found that the equatorial temperature of Mars would be -20° C. and its average temperature -38° C. If, on the other hand, like the Moon, it has no atmosphere, the temperature would still be considerably below the freezing-point of water. The only escape from this conclusion is to be found by assuming that an appreciable amount of heat is issuing from beneath the surface. It is evident, however, from a comparison of the polar and equatorial temperatures on the Earth that the internal heat of the Earth has very little effect on its surface temperature, and it is therefore reasonable to assume that the same is true for Mars. This probable low temperature is a further argument against Lowell's theory of the canals.

The method of determining the temperature of Mars can be applied also to Mercury and Venus. The values deduced for their temperatures depend, however, upon whether they

rotate on their axes in a short period or so as always to turn the same face towards the Sun. In the former case, they are about 170° C. and 55° C. respectively hotter than the Earth; in the latter case, the hemispheres facing the Sun must be at much higher temperatures still, whilst those away from the Sun must be at very low temperatures.

141. **Satellites of Mars.**—Mars possesses two tiny satellites which were discovered in 1877 by Asaph Hall at Washington. They are both very small, the larger one having a diameter of less than 40 miles and the smaller of only 8 or 10 miles. Their smallness, combined with their nearness to Mars itself, renders them difficult objects of observation. The outer and smaller one, Deimos, is only 14,600 miles from the centre of Mars; the inner one, Phobos, only 5,800 miles. Their periods of revolution are correspondingly short, viz. 30 h. 18 m. and 7 h. 39 m. respectively. Thus the month of Phobos is less than one-third that of the Martian day. Although both planets revolve about Mars in the same direction as Mars revolves around the Sun, Phobos would appear to an observer on Mars to rise in the west and to set in the east after an interval of $4\frac{1}{4}$ hours, since its rate of rotation is so much more rapid than that of Mars on its axis and is, in fact, the shortest in the solar system.

The period or month of Deimos is nearly equal to the rotation period of Mars. Its orbital motion eastward amongst the stars is therefore nearly equal to its diurnal motion westward. As a result, it rises in the east at intervals of 132 hours, equal to more than four of its months, so that in the interval between two successive risings, it goes through all its phases four times.

The orbits of the two satellites are almost exactly circular and in the equatorial plane of the planet. Mars is sensibly flattened at the poles, the polar compression being about $1/200$; the equatorial bulge tends to keep the satellites in the plane of the equator.

It is of interest to note that in *Gulliver's Travels* Swift relates that the astronomers of Laputa "have discovered two lesser stars, or satellites, which revolve about Mars, whereof the innermost is distant from the centre of the primary planet exactly three of his diameters, and the outermost five; the

former revolves in the space of ten hours and the latter in twenty-one and a half." If Swift had actually observed the satellites, these figures would have been creditably near the truth. As a conjecture, they are a remarkable coincidence.

As givers of moonlight to an observer of Mars the satellites would be of very little importance, but Phobos, with a motion relative to the stars ninety times as rapid as that of our Moon, would provide an excellent object for use in longitude determinations on Mars.

142. **The Minor Planets.**—The minor planets or asteroids, as they were named by Sir William Herschel, are a numerous group of very small planets circulating in the space between Mars and Jupiter, with a mean distance closely corresponding to that given by the vacant place in Bode's law. The total number discovered up to the present is approaching one thousand. The first asteroid to be discovered was Ceres; an extended search was being carried out for a planet assumed—on account of the gap in Bode's law—to exist between Mars and Jupiter. On January 1, 1801, Piazzi at Palermo, in the course of observations for his star-catalogue, observed a seventh-magnitude star which the next evening had perceptibly moved. Thus was Ceres accidentally discovered. Shortly afterwards it was lost in the rays of the Sun, but Gauss was able to compute an ephemeris, by employing his recently-discovered method, which enabled the asteroid to be found again exactly one year after Piazzi first observed it.

Pallas was discovered by Olbers in 1802; Juno by Harding in 1804; and Vesta, the brightest of all the asteroids, in 1807. The fifth, Astraea, was not discovered until 1845, but since that date fresh discoveries have been made continually, and the list is still growing, though any members of the group not yet discovered must be small and faint bodies. They are usually discovered on photographs of regions near the ecliptic, taken with an exposure of two or three hours. The telescope follows the stars during the exposure, and the duration is sufficiently long for the motion of the asteroid relative to the stars to be perceptible, so that its image on the plate will not be round but an elongated trail. One of the group having been found, a comparison of its position with the positions of previously

discovered asteroids known to be in the same region of the sky is made in order to ascertain whether or not it is a new member. The largest numbers of discoveries have been made by Palisa at Vienna, Charlois at Nice, and Wolf at Heidelberg.

Plate XIV (*a*) is a reproduction of a photograph obtained at Heidelberg, on which three minor planet trails were discovered. The positions of these trails may be readily found by means of the arrow-heads which point to them. Attention may be drawn to the difference in the directions of the three trails and to the difference in the brightness of the three asteroids.

143. **Size, Mass, and Brightness of Asteroids.**—The angular diameter of the four largest members of the system have been measured by Barnard with the large refractors at the Lick and Yerkes Observatories. These values, reduced to true diameters, give for Ceres a diameter of 480 miles, for Pallas 306 miles, for Vesta 241 miles, and for Juno 121 miles. These diameters are exceptionally large; those of the majority of the asteroids must be considerably less than 50 miles.

Photometric measures have shown that the albedos of the asteroids are small, falling for the most part between the albedos of Mercury and Mars, i.e. between 0.14 and 0.22. If the albedo is assumed to have a value of, say, 0.20, then from a knowledge of the orbit of the asteroid and its apparent brightness at opposition it is possible to compute its diameter. The percentage error in the resulting value may be considerable, but the order of magnitude obtained will be correct.

From the smallness of the majority of the group, it follows that their total mass cannot be large. It is known that it must be less than that of Mars, otherwise noticeable perturbations in the orbit of Mars would be detected. The total mass of the asteroids which have actually been discovered probably does not exceed one-thousandth of the mass of the Earth.

Most of these bodies are fainter than the tenth magnitude, but the brightness varies with the distance from the Earth and the phase of the illumination. After allowing for the variations due to these two causes, it is found that some show small residual fluctuations in brightness. It is possible that these are due to axial rotation and a variation in the reflecting powers of different portions of the surface.

None of the asteroids appears to possess an atmosphere. The low values of their albedoes tends to confirm this conclusion.

144. Asteroid Orbits.—The asteroid zone extends from Mars to Jupiter. Eros has a semi-axis of 1.46 astronomical units, which is smaller than that of Mars (1.52), whilst that of Hector (5.28) exceeds that of Jupiter (5.20). Eros is of great importance for the determination of the solar parallax; its orbit has a high eccentricity (0.22) and small inclination to the ecliptic, so that it can approach nearer to the Earth than any other known planet. When its perihelion passage coincides with the time of opposition its distance from the Earth is only about 14 million miles. It is therefore more suitable as an object of observation than Mars, and in addition, the observations can be made with greater accuracy since it does not possess an appreciable disc. A favourable opportunity for the determination of the solar parallax under these conditions will occur in the year 1931.

The six planets, Achilles, Hector, Patroclus, Nestor, Priamus and Agamemnon, constitute the Jupiter group. Their orbits are all near that of Jupiter and they provide an interesting illustration of a particular case of the problem of three bodies. If a body were at the third corner of an equilateral triangle at whose other two corners were the Sun and Jupiter, it can be shown that it would always remain in the same relative position if the initial velocity were suitably chosen. The above four planets satisfy the conditions approximately and oscillate about the positions of equilibrium which they would fill if they exactly satisfied them.

There are gaps in the asteroid orbits corresponding to periods of revolution which are simple fractions of the period of Jupiter. It has been supposed that these gaps have been caused by the perturbing effect of the large mass of Jupiter, which under these circumstances might be expected to be cumulative and gradually to have pulled such asteroids out of their orbits. This conclusion is not, however, supported by theoretical considerations.

145. Origin of Asteroids.—It has been suggested that the asteroids are the relics of a larger planet which has broken up. It is not possible definitely to state whether or not this is so.

The present assemblage of orbits, some of which lie entirely within others, offers no resemblance to a series of orbits passing through one point which should result from a sudden explosion. It must be remembered, on the other hand, that there may have been several successive explosions and that Jupiter and other planets have perturbed the orbits by greater or less amounts.

Another suggestion is that the matter forming the asteroids was originally uniformly distributed in a ring about the Sun, analogous to the rings of Saturn, and that perturbations by the planet Jupiter broke it up into many fragments which ultimately formed the aggregates which we now know as the asteroids. But whether either of these theories is near the truth, it is not possible to tell.

146. Jupiter.—The next planet in distance from the Sun is Jupiter, the largest and most massive of the planets. In apparent brightness, it is exceeded only by Venus. Although Venus is only one-seventh of the distance of Jupiter from the Sun, its average brightness exceeds that of Jupiter by only about one magnitude. Jupiter is, on the average, about five times brighter than Sirius, the brightest of the stars, and when near opposition is a very brilliant object.

The mean distance of Jupiter from the Sun is 483 million miles. The eccentricity of its orbit is 0.0483, so that its greatest and least distances differ by 42 million miles, being 504 and 462 million miles respectively. At opposition, its average distance from the Earth is 390 million miles, and at conjunction it is 576 million. When opposition occurs at Jupiter's perihelion, i.e. early in October, its distance is only 369 million miles. At a perihelion opposition it is about 50 per cent. brighter than at an aphelion opposition, and nearly three times as bright as at conjunction. Its orbital velocity is about eight miles per second. The inclination of its orbit to the ecliptic is $1^{\circ} 19'$.

The sidereal period of Jupiter is 4332.6 days or 11.86 years and its synodic period is 399 days, so that in the course of one year it practically moves through one sign of the Zodiac.

Its apparent diameter varies from about $50''$ at a favourable opposition to $32''$ at conjunction. Even a small telescope will

show that it is perceptibly oblate, the polar diameter being about one-seventeenth part smaller than the equatorial. Its equatorial and polar diameters are respectively 88,700 and 82,800 miles ; its mean diameter is therefore about eleven times that of the Earth. Its surface is 119 times and its volume 1,300 times that of the Earth. So that not only is Jupiter the largest of the planets, but it is also larger than all the others combined.

The mass of Jupiter has been more accurately determined than that of any other planet. The determinations have been based both on the motions of its satellites and on the perturbations which it causes in the orbits of Saturn, certain asteroids and periodic comets. On account of its large mass, these perturbations may be very considerable. In terms of the mass of the Sun, Jupiter's mass is $1/1,047.355$, which is about 318 times that of the Earth. This corresponds to a density of about one-quarter of that of the Earth. Its surface gravity is 2.64 times that of the Earth.

147. Telescopic Appearance and Rotation Period.—When seen in a telescope of moderate power, Jupiter is an object of great interest, much detail being visible which can be more easily observed and drawn than the detail visible on Mars. It is at once apparent that the principal markings run in belts or zones across the disc at right angles to the polar axis of the planet. Since the axis of Jupiter is very nearly perpendicular to its orbital plane, the boundaries of the several zones appear practically as straight lines and the complications which arise, as in the case of Mars, when the axis of the planet is inclined at a considerable angle to its orbital plane, are therefore absent (Plates XII (*b*) and XIII (*b*)).

The equatorial zone is usually very bright and conspicuous, although it occasionally takes on a tawny hue, the sequence of changes in its appearance occurring with some regularity. It is bordered to the north and south by two darker brownish zones (*see* Plate XIII (*b*)). Numerous small well-defined bright and dark spots are frequently observed in these zones, which frequently last for several months, and may be utilized to determine the period of rotation of the planet. Such observations show that, as in the case of the Sun, the period of

rotation is different in different latitudes, the rotation in the equatorial zone being more rapid than that of most of the remaining portion of the surface. At the equator, the period is about 9h. 50 m. 25 s., whilst at the poles it is about 9 h. 55 m. 40s., the transition between the two being practically instantaneous.

The increase in rotation period from equator to poles is not uniform, for Denning and Williams have shown that between latitudes 24° and 28° north is a zone with a rotation period somewhat shorter than 9 h. 49 m. It is evident that the observations cannot relate to markings on a solid body, but rather to markings of an atmospheric nature. The zones on Jupiter have been compared with the trade-wind belts on the Earth and it has been suggested that the higher velocity of certain portions of the surface are due to downward atmospheric currents which communicate a greater velocity to the lower layers and continually hasten them onwards. It is doubtful whether there is any solid surface beneath the clouds, as the variation in rotation period can be much more readily reconciled with an entirely gaseous constitution.

There is one marking on the planet which is of a semi-permanent nature. This is known as the Red Spot. It is clearly seen on Plate XIII (*b*). It was first observed in 1878 and was then a pale, pinkish oval spot; it rapidly attracted the attention of observers as it developed and attained a brick-red colour and a length about one-third the diameter of the planet. It faded considerably in subsequent years, but remained a conspicuous object on the planet until about 1919, when it gradually faded away; in 1921 it was only very faintly visible. The period of rotation of the spot is slightly variable and rather longer than that of the atmospheric belt surrounding it. The cause of the phenomenon is uncertain, but it is generally supposed that in 1878 there was an eruption of some sort on the planet and that the gases poured out over the highest cloud zone and remained in a practically stationary position relatively to it.

148. Physical Constitution of Jupiter.—The nature of the surface markings observed on Jupiter and the variations in the periods of rotation of different zones suggest a dense atmosphere. The high value of the albedo, 0.62, supports this, and other evidence is also confirmatory. The brightness

of the planet is not uniform across its disc, but decreases towards the limbs ; the limb turned away from the Sun appears the darker of the two, but this is merely an effect of phase. The decrease at the other limb is due to the greater absorption which the light from the Sun undergoes due to its longer passage through Jupiter's atmosphere at the limb. The spectrum of Jupiter also shows an appreciable strengthening of the telluric lines, i.e. those lines which are due to absorption in the Earth's atmosphere, and of certain other lines ; this can only be due to additional absorption in the atmosphere of Jupiter itself.

The rapidity of the changes occurring on the surface of Jupiter would seem to indicate that the temperature of the planet must be high. Its low density further suggests that it is largely, if not entirely, in a gaseous state except in so far as the interior may be liquefied by the pressure of the outer layers. The variable rotation period also leads to the same conclusion, and the flattened shape of the planet is in harmony with it. On the other hand, the planet, if self-luminous, can be only feebly so. When one of the satellites of Jupiter passes between the Sun and the planet, its shadow is thrown on to the planet's surface ; the portion of the surface in the shadow then appears dark, so that in contrast with the illumination of Jupiter by sunlight its own luminosity is negligible.

Jupiter is therefore a gaseous or semi-gaseous body at a high temperature and in rapid rotation. The rotation gives rise in all probability to winds blowing parallel to its equator which throw the clouds in its atmosphere into belts parallel to its equator, so giving rise to the well-known appearance of Jupiter in the telescope.

149. Satellites of Jupiter.—Jupiter is known to have nine satellites. Four of these were discovered by Galileo in 1610, one of the first results obtained with his telescope. He was able to satisfy himself as to their true character, in spite of much opposition and vituperation from the Churchmen, and to determine their periods of revolution with a very fair degree of accuracy. These four are usually called the first, second, etc. satellite, in the order of their distance from Jupiter, though they have the names Io, Europa, Ganymede, and Callisto. They are

comparatively bright and are the largest satellites in the solar system. With a pair of field glasses they may easily be seen. The remaining five satellites are named the fifth, sixth, etc., in the order of their discovery. The fifth, which was discovered by Barnard in 1892 is the nearest of the satellites to Jupiter. These five are all faint and have only been discovered within recent years, large telescopes and, in the case of the faintest, the employment of photography, having made their discovery possible. The particulars as to their distances, brightness, periods, and size are given in the following table:—

Satel- lite.	Distance in terms of Jupiter's Radius.	Distance in Miles.	Period.	Diameter, Miles.	Stellar Magni- tude.	Year of Dis- covery.
			d. h. m.		m.	
1	5.9	267,000	1 18 28	2,470	5.6	1610
2	9.4	421,000	3 13 14	2,060	5.7	1610
3	15.0	678,000	7 3 43	3,580	5.0	1610
4	26.4	1,191,000	16 16 32	3,300	6.3	1610
5	2.5	115,000	0 11 57	—	13.	1892
6	160.	7,230,000	251	—	14.	1904
7	167.	7,540,000	265	—	16.	1905
8	330.	14,910,000	739	—	16.	1908
9	345.	15,560,000	745	15	19.	1914

The four major satellites, when viewed with a large telescope, show sensible discs on which faint markings may be seen under favourable atmospheric conditions. These markings have been studied with a view to determining the periods of rotation of the satellites. From such observations, combined with observations of slight variations in brightness of the satellites, it is believed that their period of axial rotation is equal to the period of their rotation about Jupiter, so that they always turn the same face towards the planet. Their orbits are almost circular and lie very nearly in the plane of Jupiter's equator. With the exception of the fourth, they pass through the shadow of the planet and therefore suffer eclipse at every revolution; they also transit across the disc of the planet, and the shadows which they cast may easily be observed as black dots upon the planet's surface. It is difficult to observe the

satellites themselves during transit. The fourth satellite usually suffers eclipse, but its orbital plane is sufficiently inclined to the plane of Jupiter's equator for it to pass at certain times either above or below the shadow of Jupiter. Exactly at opposition or conjunction, the eclipses cannot be observed, as the shadow of the planet then lies straight behind it and therefore out of sight. At quadrature, on the other hand, the shadow projects out obliquely to the line of sight and the whole eclipse of the second, third, and fourth satellites takes place clear of the planet's disc.

The eclipses of the major satellites were used by the Danish astronomer, Roemer, in 1675, to determine the velocity of light. His announcement that light was propagated with a finite velocity was received at the time with ridicule. The periods of the satellites being known with high precision, the times of the eclipses could be accurately calculated and should recur at regular intervals. Roemer found that this was not the case: during half the year they occurred earlier than his calculated times and during the other half they occurred later. He noticed that when they came early the Earth was nearer Jupiter and when late it was farther from Jupiter than the average. He correctly explained

this discrepancy as due to the decrease or increase of the distance which the light had to travel before reaching the Earth. Thus, in Fig. 82, if S , J are respectively the positions of the Sun and Jupiter, when the Earth is at E_1 , the light has to travel the distance JE_1 before an eclipse becomes visible to an observer on the Earth; when at E_2 , it has to travel a distance JE_2 . These are the extreme distances, so that the

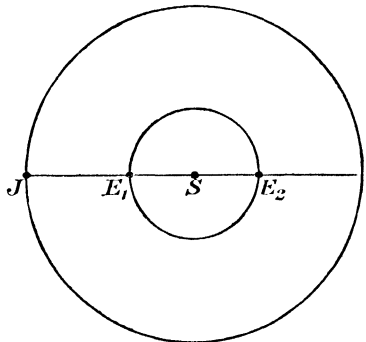

FIG. 82.—Roemer's Discovery.

greatest difference between the observed and calculated times for the accelerated and retarded eclipses corresponds to the time taken by light to travel the distance E_1E_2 , i.e. the diameter of the Earth's orbit. Roemer found for this difference

22 minutes ; more accurate modern observations give 16 min. 38 sec.

The observations of the times of the eclipses provide an easy method of determining longitudes approximately. In the *Nautical Almanac* are given the Greenwich times of the eclipses ; if the local time at the instant of eclipse be observed and compared with the calculated Greenwich time, the difference gives the longitude of the place of observation, in time, measured from Greenwich. The method is only approximate as, on account of the appreciable discs which the satellites show, the satellites are eclipsed gradually, not instantaneously. The determination with as much accuracy as possible of the times of eclipse is also important for the accurate determination of the orbits of the satellites ; they enable the positions of the satellites in space to be determined.

The satellites slightly disturb each other's motions by their mutual attractions, and a study of these perturbations enables the masses of the major satellites to be determined. The masses are respectively $1/22,230$, $1/39,440$, $1/12,500$, and $1/22,200$ of Jupiter's mass. Comparing these figures with the diameters given in the table above, it will be seen that these four satellites differ considerably in density, the density of the third, for instance, being about double that of the fourth. The mass of the largest of the satellites, Ganymede, is about double that of the Moon. •

The outer satellites fall into two pairs ; the sixth and seventh are at approximately the same distance and have nearly the same period and their orbits are interlocked the one with the other and somewhat highly inclined to Jupiter's equator. The eighth and ninth are also at about the same distance and their orbits also are interlocked. They are of particular interest because the orbits are described in the "retrograde" direction. With but few exceptions, the various members of the solar system describe their orbits in the same direction in space and also rotate about their axes in the same direction. Such motion is termed "direct," whilst motion in the contrary direction is termed "retrograde." When the eighth satellite was discovered it was at first uncertain whether it was an asteroid or a new satellite ; its apparent motion was complicated by the motion of the Earth relative to Jupiter, which

caused large apparent displacements, on account of its great distance from Jupiter, and some asteroids are known whose orbits extend beyond the orbit of Jupiter.

150. Saturn.—The most distant of the planets known to the ancients, Saturn is unique amongst the heavenly bodies with its system of rings and its ten satellites. By many it is considered the most beautiful object to be seen in a telescope.

The mean distance of Saturn from the Sun is 886 million miles. The eccentricity of its orbit, 0.0559, is somewhat greater than that of Jupiter, so that its actual distance from the Sun can vary by about 50 million miles. When opposition occurs near Saturn's perihelion, i.e. towards the end of December, it is at its smallest possible distance from the Earth, about 744 million miles. Its greatest distance, at an aphelion conjunction, is about 1,028 million miles. The variation in distance is therefore less than in the case of the nearer planets, so that its changes of brightness are not so extreme. The inclination of its orbit to the ecliptic is $2^{\circ} 30'$.

The sidereal period of Saturn is 10,759.2 days or about $29\frac{1}{2}$ years, and its synodic period is 378 days. As the sidereal period of an outer planet increases, the synodic period naturally decreases, and for an infinite sidereal period (such as a fixed star), the synodic period naturally becomes equal to the length of the year.

The apparent mean diameter of Saturn varies from $20''$ to $14''$. The planet is much more oblate than Jupiter; it is in fact more flattened at the poles than any of the other planets, the equatorial diameter being about 75,100 miles and the polar diameter about 67,200. Its mean diameter is therefore rather more than nine times that of the Earth, its surface eighty-two times and its volume 760 times that of the Earth.

Its mass can be determined with accuracy since it has numerous satellites; it is found to be $1/3,501.6$ of the mass of the Sun, or 95.2 times that of the Earth. This value corresponds to a mean density of one-eighth that of the Earth or about 0.69 that of water. It is much the least dense of all the planets. Its surface gravity is only 1.14 times that of the Earth. The inclination of its equator to the orbital plane has the high value of 27° .

151. **Telescopic Appearance and Rotation Period.**—The albedo of Saturn has the very high value of 0.72, which suggests a densely clouded atmosphere, and it is probable, for the same reasons as in the case of Jupiter, that Saturn is entirely gaseous and at a high temperature. Spectroscopic observations confirm the presence of an atmosphere, the lines due to atmospheric absorption being even stronger than in the case of Jupiter.

The characteristic feature of the planet's disc when seen in the telescope is again a series of belts running parallel to its equator, which, however, are much less clearly defined than are those of Jupiter. They are shown in Plates XII (c) and XIII (c). Well-defined spots can rarely be seen within them, and such as are seen are usually only short-lived. The rotation period can therefore not be determined with the accuracy with which Jupiter's is known. The observation of a number of spots appearing near the equator gave a rotation period of 10 h. 14 m., with an uncertainty of about one minute. In 1903, a large white spot appeared in the planet's north latitude 35° , and this had a period of rotation of 10 h. 38 m. Different zones of the planet, therefore, rotate with different periods, and as in the case of Jupiter it seems that on the whole the higher the latitude the longer is the period.

It is the ring-system of Saturn, however, which makes it so striking an object when viewed in the telescope. The aspect under which the rings are seen varies with the relative positions of the Earth and Saturn, on account of the high inclination of its equator to its orbital plane. The rings are parallel to the planet's equator, and their nodes are in longitudes 168° and 348° . The plane of the ring passes through the Earth twice during each revolution of Saturn, i.e. when the Earth passes through the nodes of the ring system, and the rings are then seen edgewise. On account of their small thickness, they then become invisible for a short time. This last occurred early in 1921. Midway between the nodes, the apparent width of the rings is almost half their length. The general appearance of the rings may be seen from Plates XII (c) and XIII (c).

The changing appearance of Saturn, depending upon the angle at which the rings are viewed, was a great puzzle to astronomers from the time of Galileo onwards. Their small telescopes, of poor defining power, were not adequate to reveal

the true nature of the rings. It was Huyghens, in 1655, who first succeeded in perceiving the ring form. Cassini, in 1675, first discovered that the ring was double, consisting of two concentric portions with a narrow black division between them. The outer ring is called ring *A*; the inner, ring *B*. In 1837, Encke observed a fine shading on ring *A*, which is visible only with difficulty. It is not yet known whether this is an actual division, similar to the Cassini division. The brightness of ring *B* falls off strongly towards the planet, and in 1850 Bond, in America, and almost simultaneously Dawes, in England, independently discovered a third inner ring *C*, called the Crepe ring, from its dusky appearance. It does not appear to be separated from ring *B* by an actual division, but there is a strong contrast in brightness at the common boundary. This ring is semi-transparent and the edge of the planet can be seen through it.

152. Dimensions of Ring-System.—The width of ring *A* is about 11,000 miles; that of the Cassini division is 2,200 miles; the ring *B* is about 18,000 miles wide, and ring *C* is just a little narrower than ring *A*. Between the edge of the planet and the inner edge of ring *C* is a space of several thousand miles.

The thickness of the rings is extremely small in comparison with their width. This is proved by the vanishing of the rings when the Earth passes through their plane. It may be concluded from this that their thickness cannot exceed about 60 or 70 miles, though it may well be less than this amount.

Structure of the Rings.—It was suggested originally by Cassini in 1715 that the rings were composed of a swarm of small satellites. Telescopes of increasing power failed to resolve the rings into separate particles, and this suggestion was not generally accepted. Bond revived it on the discovery of the Crepe ring, through which the disc of the planet was visible. There was, as yet, no direct experimental evidence to prove conclusively that the rings were so constituted. The theory became firmly established, however, when Clerk Maxwell showed by a mathematical investigation that if the rings were either solid or liquid they would form

what is termed in mechanics an unstable system, i.e. the smallest disturbing force would cause them to break up. He also showed that, if they consisted of a swarm of separate bodies, moving in orbits nearly circular and in one plane, they would form a stable system.

In 1895, Keeler obtained direct observational evidence in support of this conclusion. If the rings were solid and rotating about the planet as a rigid body, the linear velocity of a point on the outside of a ring would evidently be greater than that of a point on the inside of the ring. If, on the other hand, they form a system of satellites, then the period of revolution would increase and the linear velocity would decrease with increasing distance from the planet. We have previously seen how the motion of a source of light towards or away from the observer causes a slight displacement of the spectral lines in the directions of shorter or longer wave-lengths respectively, the measurement of the displacement enabling the velocity of motion to be determined. Keeler placed the slit of his spectroscope across the image of the planet as shown in Fig. 83 and found the shape of the spectral lines to be as

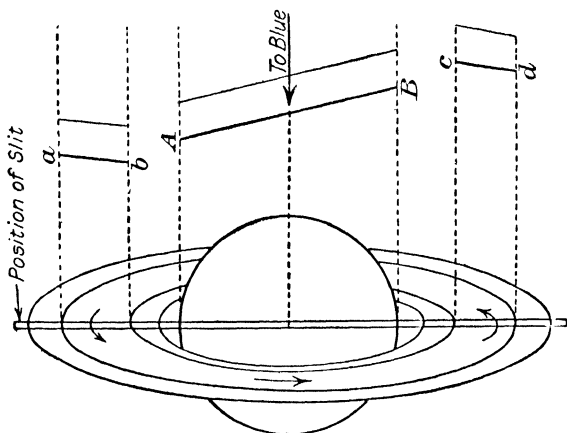

FIG. 83.—Spectroscopic Observation of Saturn's Rings.

shown above the planet. The portion AB of a line is due to the planet; the end B , corresponding to the limb which is receding from the observer, is displaced relatively to the centre towards the red, and the end A , corresponding to the limb which is approaching the observer, is displaced towards

the blue. The portions *ab*, *cd* are due to portions of the ring which are moving towards and away from the observer and are displaced towards blue and red respectively. The displacements of the outer extremities *a*, *d* are, however, less than those of the inner points *b* and *c*, proving that the inner edges of the ring rotate with a greater linear velocity than the outer edges.

The same conclusion as to the nature of the rings was obtained by Seeliger, based upon careful photometric observations of the brightness of the rings and its change with phase; and also by Barnard, who observed one of the outer satellites, Japetus, pass through the shadow of one of the rings, proving that the rings cannot be an opaque solid mass.

153. The Satellites of Saturn.—Saturn is known to possess ten satellites, the brightest of which (Titan) was discovered by Huyghens in 1655, at a period when the rings were invisible. Four more were discovered by Cassini between 1670 and 1685, also when the rings became invisible. Two more were discovered by Sir William Herschel and another by Bond. The two faintest are recent discoveries, which photography and the construction of large telescopes have facilitated.

The details of the satellite system are given in the following table :—

Name.	Distance in terms of Saturn's Radius.	Distance in Miles.	Period.			Stellar Magnitude.
			d.	h.	m.	
Mimas . . .	3.1	113,000	0	22	37	13
Enceladus . .	3.9	145,000	1	8	53	12
Tethys. . . .	4.9	180,000	1	21	18	11
Dione	6.2	231,000	2	17	41	11
Rhea	8.7	322,000	4	12	25	10
Titan	20.2	746,000	15	22	41	9
Themis	24.2	892,000	20	20	24	18
Hyperion . . .	24.5	903,000	21	6	38	14
Japetus	58.9	2,172,000	79	7	56	11
Phœbe	214.4	7,906,000	550	10	35	17

The satellites are of considerable theoretical interest. It will be noticed that the rotation period of Tethys is almost exactly double that of Mimas, and that that of Dione is almost exactly double that of Enceladus. Also the periods of Mimas and Enceladus and those of Tethys and Dione are very nearly in the ratio of 2 : 3. These four satellites, together with Rhea, have almost exactly the same orbital plane. The result is a kind of resonance effect, large mutual perturbations being set up which cause considerable variations in the orbital elements.

Titan, as its name suggests, is much larger than any of the other satellites and has a diameter of several thousand miles. It causes large perturbations in the orbits of Themis and Hyperion. The latter provided the first known instance of a special case of the problem of three bodies, its line of apsides always keeping in conjunction with Titan.

The variations in brightness, noticed in the case of Jupiter's satellites, are still more marked in the case of those of Saturn. Of particular interest are the variations of Japetus, noticed by Cassini in the seventeenth century and amounting to 1.7 magnitudes: its greatest brightness occurs at western elongation and its least at eastern elongation. The western side of the planet must be at least twice as bright as its eastern side and, like the Moon, it must rotate on its axis in a period equal to that in which it completes one revolution about Saturn.

The most distant satellite, Phœbe, provides another example of the retrograde motion previously noticed in the case of the two outer satellites of Jupiter. It can be shown theoretically that greater stability is obtained by the retrograde motion for such a distant satellite than would be obtained by direct motion.

154. Uranus.—The two outer planets, Uranus and Neptune, are of much less interest from the point of view of telescopic observation than are Jupiter and Saturn. Their appearance is very similar to the appearance which we might suppose that Saturn would have if it had no ring and were removed to their distances. Uranus was the first planet to be "discovered," the other planets known at the time of its discovery having

been known from prehistoric times. It was discovered by William Herschel on March 13, 1781, in the course of a systematic sweep of the heavens upon which he was engaged with a 7-inch reflector. The discovery was at first announced as a comet, but the computations of Laplace, five months later, showed it to be a new planet at a greater distance than Saturn. The discovery ranks as one of the most important astronomical discoveries of the eighteenth century and at the time caused great excitement. Herschel named it the *Georgium Sidus*, in honour of the king, who knighted him, gave him a pension and funds for the construction of his great 4-foot reflector with which he afterwards discovered two of the satellites of Saturn. The name of Uranus was suggested by Bode. It has since been found that Uranus had been observed at least twenty times previous to its discovery by Herschel, but it had been thought to be a star. These observations date back to one by Flamsteed in the year 1690.

The mean distance of Uranus from the Sun is about 1,800 million miles. The eccentricity of its orbit is 0.0471, slightly less than that of the orbit of Jupiter; the inclination of its plane to the ecliptic is only $0^{\circ} 46'$. The sidereal period is 22,869 days or about 84 years, the synodic period being slightly less than 370 days. The orbital velocity of the planet is rather more than 4 miles per second.

The apparent mean diameter is about 4" and varies by very little. This angular diameter corresponds to a real diameter of about 31,000 miles. There is a relatively large uncertainty attaching to this value, due to the difficulty of measuring with accuracy the small disc of the planet. The width of the spider lines in the micrometer would, at the distance of Uranus, correspond to two or three thousand miles. Adopting the above figure, however, the surface and volume are respectively about fifteen and sixty times greater than those of the Earth. Micrometric measures support the view that the planet is flattened at the poles, but the amount of the flattening cannot be stated with accuracy. Analogy with Jupiter and Saturn would confirm the probability of a flattening.

Uranus possesses four satellites, so that its mass can be determined with accuracy. It is $1/22869$ of that of the Sun,

or about 14.6 times that of the Earth. Its density is therefore about 0.25 times the Earth's, or about the same as that of Jupiter. Its surface gravity is 0.96 that of the Earth. Uranus can be seen with the naked eye, appearing as a faint star of the sixth magnitude.

155. Telescopic Appearance and Period of Rotation.—

The albedo of Uranus is 0.60, indicating a high reflecting power and a cloud-laden atmosphere. It is therefore improbable that much detail could be seen on the disc even under the most favourable conditions. There are sometimes visible faint bands or belts, which are analogous to the appearance Saturn would give if at the distance of Uranus. There are no markings sufficiently definite to enable the rotation period to be determined. As Uranus is so distant from the Earth, the influence of phase is negligible and cannot be detected even by the most accurate photometric observations. It is, therefore, possible to apply the spectroscopic method, particularly as the position of the planet's axis is known with accuracy. The satellites have a retrograde motion and the planes of their orbits are inclined at over 80° to the plane of the planet's orbit: it can be shown that the plane of their orbits must very nearly coincide with the plane of the planet's equator, and the position in which the spectroscope slit should be placed in order to detect the rotation is therefore determined. The observations of Lowell in 1911 indicated a period of rotation of about $10\frac{3}{4}$ hours.

156. Satellites of Uranus.—Uranus is known to have four satellites. Two of these, Titania and Oberon, which are the brightest and most distant from the planet, were discovered by Sir William Herschel, shortly after his discovery of Uranus. The other two, Ariel and Umbriel, were discovered by Lassell in 1851. They are small bodies and difficult to observe in the telescope. Particulars of their distances and periods are as follows :—

Name.	Distance in terms of the Radius of Uranus.	Distance in Miles.	Period.		
			d.	h.	m.
Ariel	7.0	111,000	2	12	29
Umbriel	9.9	156,000	4	3	28
Titania	16.1	253,000	8	16	56
Oberon	21.5	339,000	13	11	7

The orbits of the four satellites are nearly circular and co-planar, their plane being inclined at 82° to the orbit of Uranus and being therefore almost perpendicular to it.

The orbits are all described in the retrograde direction. When the Earth passes through the line of nodes of their orbit plane, the orbits appear edgewise as straight lines, providing a favourable opportunity for determining the inclination of the orbits. The next occasion on which this will happen is 1924. Twenty-one years after passing through a node, the plane of the orbits is seen almost perpendicularly. It is believed that the periods of axial rotations of the satellites agree with their respective revolution periods.

Their probable diameters are of the order of 500 miles and are therefore much larger than the satellites of Mars, though much smaller than the Moon.

157. **Neptune.**—As mentioned in § 154, it was found after the discovery of Uranus that it had frequently been observed before and taken for a fixed star. Although the older observations were not of very great accuracy, they proved sufficiently accurate to be of value for the calculation of the orbit of the planet, covering as they did a complete revolution. It was found by Bouvard that it was not possible to satisfy both the old and the new observations, and he therefore based his computed orbit entirely on recent observations. After a short time, it was found that Uranus was not in the position computed by Bouvard's tables, and Bessel, who examined the matter thoroughly, concluded that the discrepancies between the computed position and both the new and the old observed positions must be due to a real physical cause and suggested

the possibility of the existence of an unknown planet beyond Uranus, which was invisible to the naked eye, but which by its attraction on Uranus was causing the observed discrepancies. The French astronomer Leverrier and the English astronomer Adams adopted this suggestion and independently computed the position of the hypothetical planet. Neptune was discovered very close to the positions which they assigned to it (§ 121).

The mean distance of Neptune from the Sun is about 2,800 million miles, or rather more than thirty times the mean distance of the Earth. The eccentricity of its orbit is only 0.0085, which, with the exception of Venus, is much smaller than that of any other planet. Owing to the large size of the orbit, this small eccentricity corresponds to a difference of over 50 million miles between the greatest and least distances of the planet from the Sun. The inclination of the orbit to the ecliptic is $1^{\circ} 47'$. The sidereal period of the planet is 60,181 days, or about 165 years, nearly double the period of Uranus. Relatively to the fixed stars, the planet therefore moves only about 2° per year; this amount, though apparently small, corresponds to a motion of about $20''$ per day. Relative to the Earth, the daily motion varies between $101''$ at opposition and $133''$ at conjunction. This motion enabled the planetary nature of Neptune to be established within twenty-four hours of its discovery. The orbital velocity is about $3\frac{1}{2}$ miles per second.

The apparent mean diameter is about $2.6''$ and is subject to little variation. This angular diameter corresponds to a linear diameter of about 33,000 miles. Neptune is, therefore, somewhat larger than Uranus; its volume is about eighty-five times that of the Earth. It has one satellite, which enables the mass to be determined; it is found to be $1/19,314$ that of the Sun, or about seventeen times that of the Earth. Its density is therefore only about 0.24 of that of the Earth, or about 1.30 of that of water.

158. Telescopic Appearance.—In the telescope, Neptune appears as a small greenish disc upon which no markings are visible. Nothing is known as to its period of rotation. Its physical constitution is probably similar to those of Jupiter, Saturn, and Uranus. Everything points to the existence of a

dense atmosphere. The albedo, though not so high as that of Jupiter, has the relatively high value of 0·52. The spectrum is similar to those of Jupiter and Uranus, with a number of dark absorption lines, due to the absorption in the planet's atmosphere. There is in particular one prominent band in the spectra of all three planets which has not been identified in the spectra of any known terrestrial substance.

✓159. **The Satellite of Neptune.**—Neptune possesses one satellite, which was discovered by Lassell within a month after the discovery of the planet. It is distant from Neptune about 15 of the planet's radii, or 284,000 miles. Its period of revolution is 5 d. 21 h. 2 m. It is a faint object—Neptune itself is only of the eighth or ninth magnitude—which is best observed photographically. It is of about the same brightness as Oberon, the outer satellite of Uranus. Its size has been estimated as about equal to that of the Moon. The inclination of its orbit to the ecliptic is about 35° and the orbit is described in the retrograde direction.

160. **On the Possibility of an Intra-Mercurial or Trans-Neptunian Planet.**—The possibility of the existence of a planet between Mercury and the Sun, or beyond Neptune, has received much discussion. A planet between the Sun and Mercury was actually announced as having been discovered by a Dr. Lescarbault in the year 1859, and accepted as genuine. The name Vulcan was given to the supposed planet. Little doubt exists to-day that the planet does not exist. The transit of such a planet across the Sun's disc could scarcely have escaped observation and, if it existed, it should be a conspicuous object at the time of a total eclipse, unless hidden behind the Sun's disc. But such a planet has neither been seen nor photographed, although photography can reveal stars as faint as the eighth magnitude which are only a few minutes of arc distant from the Sun.

Leverrier discovered that the perihelion of the planet Mercury had a motion greater than it was possible to account for theoretically. The attractions of other planets cause a slight progressive motion of the perihelia of their orbits: in the case of all the planets except Mercury, the observed advance in the perihelia agreed with their calculated values within the

errors of observation. In the case of Mercury, there was an unexplained residual of about $43''$ per century. One suggestion put forward to account for this motion was that there were one or more planets within the orbit of Mercury. This explanation, however, raises other difficulties, and the motion of the perihelion can now be otherwise accounted for by the relativity theory of gravitation formulated by Einstein, for the details of which the reader should refer to one of the many books which deal with this theory. There is therefore at present no reason to suppose that an intra-Mercurial planet exists.

The question of a possible trans-Neptunian planet is still undecided. There are slight discordances between the calculated and observed positions of Uranus and Neptune which have been tentatively attributed to the attraction of an unknown planet. But as their amount is only about 2 seconds of arc, and not much greater than the possible error of a single observation of the position of the planets, it is evident that the position assigned to this hypothetical planet from a discussion of these discordances must be liable to considerable error. As the planet, if it exists, will be found to be of only about the thirteenth magnitude and its motion relative to the stars will be very slow, it must prove a difficult object to detect. It is even possible that the discordances between the observed and calculated position of Uranus and Neptune may be due to other causes. At present, therefore, it seems that the probability of the discovery of an ultra-Neptunian planet is small.

CHAPTER XI

COMETS AND METEORS

161. Comets, or *stellæ comatæ*, i.e. hairy stars, as they were formerly called, are bodies which, moving under the influence of the Sun's gravitation, appear in the heavens at irregular intervals. They gradually increase in brightness for a while, after which they grow fainter and fainter until they can no longer be observed. Only a small proportion of the comets which are discovered become sufficiently bright to be visible to the naked eye. Those which do so appear as a hazy cloud with a brighter nucleus from which a fainter tail extends in the direction away from the Sun, visible sometimes to a great distance. In physical constitution they are very different from planets, although they are to be considered, even if only temporarily, as members of the solar system.

162. **Number of Comets.**—It has been estimated that, on the average, only about one comet out of five discovered becomes visible to the naked eye. The discoveries of comets since the invention of the telescope have therefore greatly increased in number. There are records extant of about 400 comets previous to the year 1600, which must all have been bright objects: this number includes the different returns of periodic comets. The appearance of a bright comet was formerly regarded with great alarm and considered as an omen of impending disaster, and it is, perhaps, for this reason that the records of their appearances are numerous. The employment of "comet-seekers," telescopes with a large field of view and a low-power eyepiece, has greatly increased the numbers of discoveries of comets: Pons, for instance, discovered 27 comets between 1800 and 1827. Newcomb estimated that between 1500 and 1800 there were 79 comets

visible to the naked eye. It is probable that some of the less conspicuous naked-eye comets were either not observed or else that no records were kept of their appearance, for Denning finds that, between 1850 and 1915, 78 comets were discovered which became visible to the naked eye. Between 1800 and 1850, there appear to have been at least 30 naked-eye comets. It would therefore seem that, on the average, there is at least one naked-eye comet per year. Some years are particularly favoured; thus, in 1911, there were four naked-eye comets. In other years there may be none. The average number of comets now discovered per year is probably about five or six.

163. Old Views on Comets.—Aristotle and his followers believed that comets were exhalations from the Earth which had become inflamed in the upper regions of the atmosphere. This theory was doubtless based to a certain extent upon observation: comets attain their greatest brightness when nearest the Sun and would then be visible shortly after sunset or before sunrise; the tail of a comet points always away from the Sun, so that the comets would then be observed with their tails pointing upwards and appearing like a rising flame. The views of Aristotle were generally accepted until about the seventeenth century. Tycho Brahe first showed that comets must be more distant than this theory required: by comparing observations of the position of the comet of 1577 amongst the stars, made at different places in Europe, he concluded that its distance must be much greater than that of the Moon. He found the same results for the comets of 1582, 1585, 1590, 1593, and 1596. Tycho supposed their paths to be circular; Kepler, on the other hand, supposed them to move in straight lines. That their orbits were parabolas was first suggested by Hevelius, who noticed that the path of a comet was curved near perihelion. It was proved by Doerfel for the particular case of the comet of 1681 that the path was a parabola with the Sun in the focus. A method for determining the parabolic orbit of any comet was first given by Newton, and, using this method, Halley was able to determine the paths of 24 bright comets which appeared in the years 1337 to 1698. From the similarity of the paths of the comets of 1531, 1607,

and 1682, he concluded that the three comets were identical—the famous comet bearing his name: the records of this comet go back without a break to the year 989 and with a few gaps back to the second century B.C. Halley therefore concluded that the orbit, though very nearly parabolic, was in reality elliptic; and predicted the comet's return in 1759. It was observed in that year, after Halley's death. Its most recent appearance occurred in 1910. A photograph of the comet obtained in 1910 at the Union Observatory, Johannesburg, with Venus in the same field of view, is reproduced in Plate XIV (b).

164. **Orbits of Comets.**—The orbits of about three hundred comets have been determined with some certainty. The majority of these orbits are parabolic. If a cometary orbit were accurately parabolic or hyperbolic, it would imply that the comet had entered the sphere of attraction of the Sun from outer space and as a result had been deviated from its path although not captured, the comet again passing away out of the solar system.

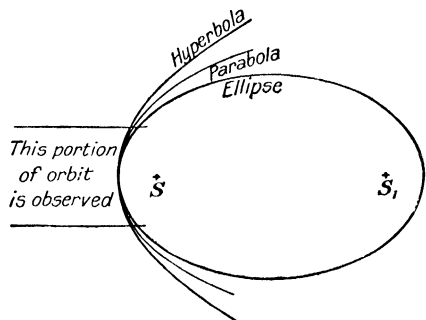

FIG. 84.—Cometary Orbits.

But supposing the path of a comet were elliptic and its period several hundreds or thousands of years, the accuracy of the observations might not be sufficient to distinguish between an elliptic or a parabolic orbit. Comets are visible only in that portion of their path near to the Sun, and in that portion the differences between an ellipse, parabola, and hyperbola are small (Fig. 84): also a comet, being diffuse, cannot be observed with the same accuracy as a planet. When the orbit has been determined as a parabola, the logical inference is, therefore, that its eccentricity is so nearly unity that a period cannot be assigned. In a few cases, hyperbolic orbits have been determined. A careful examination of these has been made by Strömgen, who concluded that either the observations

were not sufficiently accurate or consistent to justify the assumption of a hyperbolic orbit, or that the hyperbolic orbit had been caused by planetary perturbations. There thus seems to be no conclusive evidence of any comet having entered the solar system from outside. This is further confirmed by the absence of any preference shown by the direction of approach of comets for the direction in space in which the solar system is moving as compared with the opposite direction. If comets entered the system from outside, more would be overtaken in the direction in which the system is moving than would overtake the system in the opposite direction. There is no evidence for such a tendency.

For about fifty comets elliptical elements have been determined, but only about twenty of these can be properly described as "periodic" comets, i.e. comets which have been observed at more than one return. The return of a comet with a definitely elliptical path may be missed, either because of an inaccuracy in the determined period or because the orbit may have been changed by planetary perturbations: in other cases, the return may not be observed on account of the comet having broken up.

The inclinations of the comets' orbits to the ecliptic have all values from 0° to 90° , but with a few exceptions, of which Halley's Comet is the most notable, the direction of motion is the same as that of the planets.

165. Origin of Comets.—We have already pointed out that there is no evidence of any comet having entered the solar system from outside. From the fact that the axes of cometary orbits do not show any preferential direction, it has been conjectured that comets originated in a system of cosmical matter, at a very great distance from the Sun and moving with it. In the absence of disturbing forces due to planetary attractions, portions of matter from this system attracted towards the Sun would describe parabolic orbits. The perturbations due to planetary attractions would change these orbits into either an elliptical or hyperbolic shape. In the latter case, the comets would pass out of the system and not return. The nearer the comet passed to a planet, the greater would be the perturbations. They would also be

greater in the case of comets with orbits inclined at only a small angle to the ecliptic and moving in the direct sense than in the case of comets with orbits inclined at large angles to the ecliptic or moving in the retrograde direction in orbits of small inclination. For, in the first case, the comet would remain for a longer time in the sphere of influence of the planet. It would therefore be anticipated that the comets with the most elliptical paths would be those which move in the direct sense in orbits inclined to the ecliptic at a small angle. Experience tends to confirm this conclusion: of 20 periodic comets, Halley's and Temple's Comets are the only two with a retrograde motion, and 16 have inclinations of less than 30° .

166. Families of Comets.—Of the comets for which elliptical orbits have been determined, it is noticeable that for the large majority the aphelion is at about the same distance from the Sun as the orbit of Jupiter. The periods of this group of comets, comprising some thirty or more members, all lie between three and eight years. They, therefore, pass at some point in their paths very near to Jupiter's orbit and are spoken of as Jupiter's "family" of comets. The orbits of the various members of the family have not necessarily any special resemblance to one another except in period and aphelion distance. Other planets also have families of comets, though not so numerous as that of Jupiter. Uranus has two, Neptune has six (of which Halley's Comet is one), and Saturn has two. The large number belonging to Jupiter is to be attributed to its large mass, its great perturbing force having enabled it to capture more comets than the other planets. It is possible that some of the members of Jupiter's family may have originated in parent comets which were split up under the attracting forces of the Sun and Jupiter which differ for different parts of the extended comet.

There are two comets, 1862 III (i.e. the third comet to pass perihelion in 1862) and 1889 III, whose aphelion distances are respectively 47.6 and 49.8 astronomical units; or about 50 per cent. greater than the distance of Neptune. It has been suggested that these may be members of a family of comets belonging to an undiscovered planet beyond Neptune.

The capture of a comet by a planet may be illustrated by

the case of Comet Brooks, 1889 V. This comet was found to have a period of about 7 years, and Chandler, by computing back from the observed positions, found that, in 1886, the comet and Jupiter had come within a small distance of one another, with the result that the comet's previous orbit had been entirely altered: he also computed that the previous orbit was much larger and that the period was then 27 years. In 1886, the comet probably passed so near to Jupiter that it was within the orbit of its first satellite; in 1889, after its discovery, Barnard observed that the comet was double, and that the two parts were slowly separating at such a rate that the disruption could be traced back to the time of its close passage to Jupiter.

A comet belonging to one of the planet families may not necessarily remain permanently a member of that family. At some other part of its orbit it may suffer perturbations by another planet and its orbit again be considerably modified. The orbit may even be changed into a hyperbola so that the comet never returns. The masses of comets are so small that they produce no perceptible perturbation on the planets.

167. Groups of Comets.—Comets which have orbits whose elements are so similar that it may be concluded that they had a common origin are said to form a group. Several such groups are known. The most remarkable group is one composed of the great comets 1843 I, 1880 I, and 1882 II. Of these 1880 I had a tail extending over 40° and 1882 II had one nearly as long. These comets all had retrograde motion, very small perihelion distances, and long periods. A bright comet which appeared in 1668 is probably either identical with one of the three comets mentioned or is a further member of the group. Other instances which may be mentioned are the comets 1742–1907 II; 1812–1884 I; 1884 III–1892 V.

From the close similarity of the elements of the orbits of two comets it is not to be assumed, however, that they have necessarily had a common origin, although there is an *a priori* probability. For conclusive proof, it would be necessary to trace back the previous history of each comet, allowing for the effects of planetary perturbations. If the paths approached close together and the comets reached the adjacent points at

the same time, the probability of a common origin would be greatly strengthened. On the other hand, the failure of the comets to converge in this manner would only disprove the possibility of a common origin if it were certain that at no point in their previous history had either comet disrupted, with consequent alteration of path.

The actual disruption of a comet has been witnessed more than once. The case of Comet Brooks was mentioned in the previous section, the disruption having been due in this case to the attraction of Jupiter. Biela's Comet provides another example; this comet was discovered in 1826 and was found to have a short period, 6.6 years. It was observed at return in 1832, missed in 1839 on account of unfavourable position, and observed again in 1846. When first observed in that year it had the normal appearance of a comet, but shortly afterwards the nucleus divided into two parts which gradually separated. At the next return in 1852, the two twin comets were again observed, but their separation had greatly increased. They did not appear at subsequent returns, but in the year 1872, as the Earth passed the track of the lost comet, there was a fine meteor display. This was repeated at subsequent returns, proving that the comet had in the interval completely disrupted into fragments.

Fig. 85 illustrates an early stage in the disruption of a comet. On June 4, 1910, a tail was detached from the head of Halley's Comet and receded rapidly from the nucleus. The figure

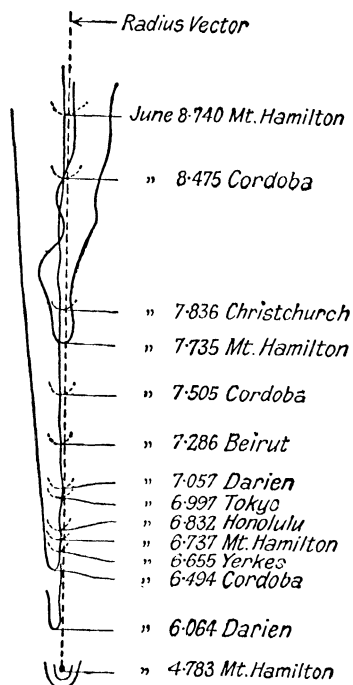

FIG. 85.—Successive Portions of the Inner End of a Detached Tail of Halley's Comet, June 4-8, 1910.

shows the position of the inner end of the tail as observed at various observatories within the few succeeding days. The detached tail appears to recede with an accelerated motion, finally becoming completely separated from the parent comet.

168. Appearance of Comets.—A comet, when first discovered, usually appears in the telescope as a faint nebulous or hazy cloud, in which may sometimes be distinguished a central condensation. As the comet approaches the Sun, the appearance greatly alters: the typical comet at this stage consists of a triple structure—a head, a nucleus, and a tail (Plates XIV, XV, XVI). The head is the cloud of nebulous matter which was seen when the comet was much fainter: it now has a more clearly-defined outline which is, however, never sharp. In shape it is usually round or elliptical. The nucleus is a bright point near the centre of the head; it is more or less star-like and is the most suitable portion of the comet to point on in determining its position. From the head there streams out a nebulous tail, with a cylindrical outline, whose axis lies in the plane of the comet's orbit and is directed away from the Sun. The brightness of the tail increases towards the nucleus, from which it seems to spring. Particularly in the neighbourhood of the nucleus, much structure may be seen in the tail: this is best studied by the employment of photographic methods, which have in a comparatively short while provided more information than was obtainable from all the earlier visual observations of comets. Comet Morehouse (Plate XVI) provided a good example: the tail of this comet was continually and with great rapidity changing its shape. The structure shown in Plate XVI (*a*) is entirely different from that in Plate XVI (*b*).

As the comet approaches the Sun, the tail follows it, but when it has passed perihelion, the tail precedes it, pointing always away from the Sun. It does not therefore consist of matter left behind by the nucleus. In some comets, the structure of the tail exhibits rapid variations from night to night, the course of which may be traced by photographs obtained at sufficiently short intervals.

169. Size and Mass of Comets.—The dimensions of

comets vary greatly, some being comparatively small and others almost inconceivably large. The diameter of the nucleus can only be approximately assigned, but may attain to several thousands of miles. The head itself may be very much larger; that of the celebrated comet of 1811 has been estimated to have had a head whose volume was about 350 times that of Jupiter. On approaching the Sun the head appears to contract, though this may possibly be only an optical phenomenon, as it is not easy to give a physical explanation. The length of the tail may be a few million miles only, or, in some cases, may exceed the distance of the Sun from the Earth, with a volume some thousands of times that of the Sun.

In view of these enormous dimensions, it is surprising that the masses of the comets are insignificant. Although in no case has the mass of a comet been determined, several lines of evidence confirm this assertion. In the first place, although comets frequently pass so near to the Earth or to one of the other planets that their orbits are completely changed, it has never been possible to detect any perturbing effect produced by the comet on the planet. Further, the comet of 1770 and comet 1889 V passed through the satellite system of Jupiter without producing any perturbations. Certain optical phenomena presented by comets also tend to confirm the smallness both of their mass and of their density. Thus the bright daylight comet of 1882 became quite invisible when it passed in front of the Sun.

The only conclusion which can be drawn as to a comet's mass is, therefore, that it is very much smaller than that of the Earth, probably not exceeding $1/100,000$ of the Earth's mass and possibly being much smaller still. Even so, the mass may amount to many millions of tons.

The density must therefore also be extremely small. Small stars may be seen through a comet's head, quite near the nucleus, without suffering any perceptible diminution in brightness (*see* Plates XV and XVI). The *average* density of the head is probably of the order of the density of the residual air in a chamber exhausted by a good air-pump: that of the tail must be much smaller even than this. From the fact that many comets have broken up and subsequently produced

showers of meteors, it does not seem unreasonable to suppose that the head of a comet consists of meteoric stones, widely separated from one another. The fact that the heads of comets show no phase effects is consistent with this supposition.

170. Spectra of Comets.—The first spectroscopic observation of a comet was made by Donati in the year 1864, and revealed certain bright lines superposed upon a faint continuous background. This is typical of comet spectra. It was shown by Huggins in 1868 that the bright lines usually observed are identical with those given by the blue flame of a Bunsen burner and indicate, therefore, the presence in the comet of gaseous carbon compounds (such as cyanogen). In some cases bright metallic lines of sodium, magnesium, and iron may be observed. These observations settled the question, which had previously been much discussed, whether comets shone by their own light or merely by reflected sunlight. Attempts to determine to what extent the light from comets is polarized have yielded negative results, the faintness of most comets making the observations very difficult. The presence of bright lines in the spectra can only be due, however, to a self-luminous body. The continuous background, on the other hand, is doubtless due to reflected sunlight.

With the application of photography, it has become possible to study the spectrum in the ultra-violet and also the spectrum of the tail. This has revealed differences from the normal hydrocarbon spectra, which are explained as being due partly to a mixture of carbon monoxide and cyanogen and partly to the reduced pressure. The electrical phenomena obtained by discharge through a Geissler's vacuum tube enable the assertion to be made with a high degree of probability that a comet's self-luminosity is due not to an actual combustion, but to an electrical phenomenon. This is in accordance with what might be anticipated from the low density of the comet.

171. The Nature of a Comet's Tail.—Many theories have been advanced to account for the apparent repulsion of a comet's tail from the Sun. Zöllner suggested that it was due to an electrostatic repulsion of matter ejected from the nucleus.

Bredichin developed a more complete theory based upon this suggestion. The repulsion was supposed to be inversely proportional to the molecular weight of the ejected gas. The repulsive force would therefore be greatest if the ejected gas were hydrogen. He divided the tails into three types: (1) Long straight rays, the cross-section being very small compared with the length. Comet Morehouse (Plate XVI) had a tail of this type. The repulsive force due to the Sun's electric field was supposed to be eight or more times as great as the gravitational attraction: this would cause particles to leave the nucleus with a relative velocity which would rapidly increase. Such tails were supposed to consist mainly of hydrogen. (2) The second type is shorter, more curved, and with a relatively larger cross-section (Plate XV (b)). In this case, the repulsive force is supposed to be about double the gravitational attraction, and the tail to consist mainly of carbon compounds. (3) The third type is short, stubby, and greatly curved, and due to matter for which the repulsive force is only a fraction of the gravitational force. This type is supposed to be composed of metallic gases. In the case of bright comets, the three types merge and may all be detected more or less clearly in the compound tail. Compound tails are to be seen in Plates XV and XVI. The three types are illustrated in Fig. 86.

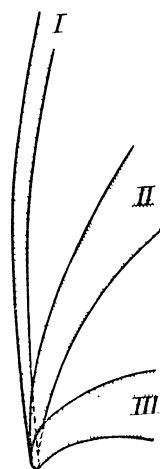

FIG. 86.—Types of Comets' Tails.

More modern views are in favour of a different theory. It was shown theoretically by Maxwell, and demonstrated experimentally by Lebedeff and by Nichols and Hull, that when light falls upon a body it exerts a pressure upon it. This pressure is very small and proportional to the area upon which the radiation impinges. Suppose it falls upon a small sphere near the Sun: then the gravitational force of attraction on the sphere due to the Sun is proportional to the cube of its radius, and therefore if the radius becomes sufficiently small it may be anticipated that the gravitational attraction will ultimately become less than the radiation pressure, which

is proportional to the square of the radius. Theoretical investigation shows that this would be the case if the diameter of the particle were between 1.5μ and 0.07μ where $1 \mu = 1/1,000$ mm. A sphere of diameter equal to the smaller of these limits would still be large compared with the size of a gaseous molecule: if, therefore, this theory is correct, the tail of a comet is not truly gaseous in nature, but is composed of a cloud of very small discrete particles. Bredichin's three types of tails may be accounted for by supposing there are particles of three different densities.

The tail of a comet accordingly appears to be composed of small particles of matter, ejected from the nucleus and repelled by radiation pressure from the Sun. The total matter so repelled is probably small in amount and presumably is dissipated into space.

172. Effect of Possible Collision with the Earth.—In June, 1921, the Earth narrowly escaped collision with Pons-Winnecke's comet, which passed its perihelion a few days too early for a collision to occur. It has been estimated that such an occurrence should happen on the average once in every 15 million years. Our present knowledge of the constitution of a comet does not render it probable that such a collision, should it occur, would be a serious matter. There is only one piece of evidence of such a collision having occurred in the past, the existence of a cup-shaped crater in Arizona which bears a general resemblance to the lunar craters. This is about three-quarters of a mile in diameter and several hundred feet deep. Many small iron meteorites have been found in its vicinity. It is estimated that the outer crust of the Earth is 100 million years old, and this is the only instance of a supposed collision which is known. It has also been thought that the gaseous tail of the comet would have poisonous effects, but the density of the gas is so low that the passage of the Earth through the tail would pass entirely unnoticed.

173. Meteors.—Closely connected with comets are meteors or shooting stars. It is only within comparatively recent years that the nature of these bodies has been definitely settled. Shooting stars may be seen on any clear moonless

night, though on some nights they are much more frequent than on others. The brightness of the majority noted is about equal to that of the naked-eye stars, though a few are as bright as or brighter than Jupiter and Venus. The brighter ones leave trains which may persist as long as two or three minutes. Occasionally, very bright meteors are observed which from their appearance are called fire-balls. These may be dissipated in an explosion of considerable violence, accompanied by a loud report. No sound, however, accompanies the dissipation of the ordinary shooting star.

The heights and velocities of meteors may be determined by observing their positions relatively to the stars from two stations some miles apart and noting their time of flight. It is thus found that the mean height at which they are first observed is about 80 miles, and that at which they disappear is about 50 miles. The length of visible path may be any distance up to several hundred miles. The average velocity with which they enter the Earth's atmosphere is probably about 26 miles per second; this is the velocity which a body moving from rest at a great distance under the action of the Sun's attraction would attain when it had attained the distance of the Earth. The larger meteors or fire-balls first become visible at greater heights, up to 100 miles, and penetrate more deeply into the Earth's atmosphere, sometimes to a height of only 5 or 10 miles. Their velocity decreases rapidly during their flight, owing to the resistance of the Earth's atmosphere to the motion.

The flight of a fire-ball is accompanied by a succession of explosions, by which fragments are torn off from the principal body. These are accompanied by variations in brightness. The path of the fire-ball is not, in general, straight, but more or less irregular, probably due to the resistance of the air on a body of irregular shape. In the case of shooting stars, these variations in brightness and direction of motion are not apparent to the naked eye. Occasionally, however, they are photographed by accident, and an examination of their trails on the photographic plates reveals the irregular changes in brightness and slight deviations from rectilinear motion.

The numbers of shooting stars which may be observed is very large. The average hourly number of visible shooting

stars which may be seen by a single observer varies from about six or seven on some nights to as many as sixty or seventy on others. If the whole sky could be watched, the average number visible in one hour would probably not be less than thirty to sixty. These, however, would be only the meteors which enter the Earth's atmosphere within a few hundred miles' distance from the observer: it has been computed that the total daily number of meteors which enter the Earth's atmosphere cannot be fewer than several millions. Very few of these ever reach the Earth's surface, the large majority being completely burned up before they reach the surface by the heat generated by friction in the Earth's atmosphere. Such meteors as do reach the surface are generally called aerolites or meteorites. They are probably essentially the same as the normal meteor or shooting star, the distinction being one of size only.

The majority of the aerolites which are found or are observed to fall consist of masses of stone—limestone, magnesia, or siliceous stone, generally mixed with grains or globules of iron. A small percentage consist of nearly pure iron, usually alloyed with a relatively small amount of nickel. Some contain iron and stone in nearly equal proportions. No chemical element has been found amongst them which is not known on the Earth. The mass of an aerolite may vary from a few ounces to several tons. The masses of the shooting stars are not known with certainty, but they are believed to be very small, in general not exceeding a fraction of an ounce. The entrance of meteors into the Earth's atmosphere is continually adding to its mass, but the rate of growth is relatively exceedingly slow. Even though each meteor had a mass of a quarter of an ounce (an estimate probably much in excess of the truth), the daily addition to the Earth's mass would only be about 100 tons, and at this rate of increase it would take 1,000 million years to add sufficient matter to increase the radius of the Earth by 1 inch. The effect of the increase in mass would be a shortening of the length of the year; but the total effect would be negligible, amounting to less than $1/1,000$ of a second in 1 million years.

174. Meteor Radiants.—If the paths of all the meteors

visible on any one night are noted and then plotted on a celestial globe, it will be found that they are not distributed at random over the heavens, but that many of them when produced pass, within the accidental errors of observation, through a single point. Such a point is called a meteor radiant. The right ascension and declination of the radiant is the same for all observers. This indicates that the meteors, whose paths pass through the radiant, were, before they encountered the Earth's atmosphere, moving through space in parallel paths. For since the position of the radiant amongst the stars is independent of the position of the observer, it must be considered as infinitely distant, and two parallel lines in space, if seen projected on the celestial sphere, would appear to pass through the same point, viz. the point in which a line from the centre of the sphere parallel to this direction meets the sphere.

All meteors having the same radiant are said to constitute a meteor swarm. If the path, before encountering the Earth's atmosphere, of one of the meteors of a swarm passes through the position of the observer, that meteor would apparently be stationary in the radiant point. If the actual lengths of path through the Earth's atmosphere are about the same for all the meteors of a given swarm, then the apparent length of path will be greater, the greater the distance from the radiant point at which the meteor appears: for the angle between the direction of the meteor's motion and the direction to the point of appearance will be greater.

Besides those meteors which belong to definite swarms, there are a large number of sporadic meteors. The frequency of appearance of these has a daily and a yearly variation: the hourly number observed during any one night increases from the early evening until about three or four hours after midnight: the mean hourly frequency for a single night has a minimum in the spring, a maximum in the autumn, and intermediate values at the solstices. The directions of motion are also not uniform: more than 50 per cent. come from the east, and about equal numbers from the north, south, and west. These phenomena can be simply accounted for by the motion of the Earth around the Sun. The direction of motion of the Earth at any instant is towards the point in the ecliptic

at which the Sun was three months previously: this point is called the apex of the Earth's motion. The combination of the motion of the Earth and that of a meteor swarm causes an apparent displacement of the radiant point towards the apex, a phenomenon comparable to the displacement of the position of a star on account of aberration. The greater the altitude of the apex, the fewer the number of radiants which could not be observed. It may be deduced from the relative velocities of meteor swarms and of the Earth, that if the apex was in the observer's zenith, about five-sixths of all radiants would be seen; if on the horizon, about one-half; and if in the nadir, only one-sixth. The diurnal variation in the hourly frequency of meteors follows from this, for the altitude of the apex is least at 6 o'clock in the evening and greatest at 6 o'clock in the morning: the maximum frequency would, however, be observed somewhat earlier than the latter time, as with the on-coming of dawn the fainter meteors would be missed. The yearly variation is due to the change in the declination of the apex from -23° to $+23^\circ$, following the declination of the Sun. The apex is on this account highest (in the northern hemisphere) at the autumnal equinox and lowest at the vernal equinox. The preponderance of meteors from the east is due to the apex being east of the meridian during the greater portion of each night.

175. Connection between Comets and Meteor Swarms.

—The existence of meteor radiant points, as we have seen, to the occurrence of swarms of meteors moving in parallel paths: the fact that their velocity on entering our atmosphere is the parabolic velocity suggests that these swarms are moving in parabolic (or nearly parabolic) orbits around the Sun. The similarity between the orbits of several periodic comets and those of certain meteor swarms suggested a connection which was verified when, after Biela's periodic comet had been lost, a magnificent meteoric shower was observed in 1872 as the Earth passed through the old track of the lost comet (§ 167).

The following meteor showers and periodic comets are known definitely to be related to one another:—

Radiant in Constellation.	Meteor Shower.	Date of Shower.	Comet.	Period.
Lyra	Lyrids	April 20-21	1861 I	415 years
Perscus	Perseids	August 10-11	1862 III	120 „
Leo	Leonids	November 14-15	1866 I	33½ „
Andromeda	Bielids	November 23	Bicla	6¼ „

The meteors in each of these cases are extended more or less uniformly in an elliptical ring about the Sun, one of the points of intersection of which with the ecliptic lies near the Earth's orbit. In the case of the Leonids and Bielids, the meteor swarm does not occur every year, showing that the meteors are stretched out through a relatively small portion of the orbit: thus, in the case of the Leonids, the swarm takes about three years to pass any given point. The Lyrids and Perseids, on the other hand, occur with about the same frequency each year, indicating that in these instances the swarm is fairly uniformly distributed along the orbit. There seems little doubt that the above-mentioned meteor swarms and comets are definitely associated, but it is not so certain whether in all cases the meteor swarm is the result of the disruption, partial or complete, of the comet: for instance, the Leonid meteor shower has been traced back to the year 902, and in this case it would appear as though both the comet and the swarm might be constituent parts of a cosmic cloud.

The extension of the swarm along the orbit is due to the attraction of the Sun and planets and is probably to some extent a criterion of the age of the swarm. On this view, the age of the Lyrid and Perseid showers would be much greater than that of the Leonids, which themselves are at least several hundred years old.

176. The Zodiacal Light.—The zodiacal light is a faint hazy band of light extending from the Sun along the ecliptic. The brightness decreases with increase of distance from the Sun to a distance of over 170° , after which it increases to a patch of light a few degrees in diameter at a point exactly opposite to the Sun, called the counter-glow. The zodiacal light is best seen in the evening in February, March, and April,

because the portion of the ecliptic east of the Sun's position is then most nearly perpendicular to the western horizon. In the early morning, it is best seen in the autumn. For the same reason, it can be better observed in the tropics than in more northern latitudes: it may then be seen extending entirely across the sky, forming a complete ring. The portion near the Sun is relatively bright, but the more distant portions are so faint that clear air, free from smoke and dust and the glare from artificial illumination in cities, is necessary for it to be observed.

The spectrum of the zodiacal light shows no bright lines but is mainly a continuous spectrum in which some of the more prominent Fraunhofer lines have been detected. This probably indicates that the light is mainly or entirely reflected sunlight. The most plausible explanation of the zodiacal light is, therefore, that there exists in the neighbourhood of the Sun, and extending beyond the orbit of the Earth, a thin flat sheet of rarefied matter, lens-shaped and symmetrical with respect to the ecliptic. The light from the Sun reflected or scattered by this matter gives the appearance of the zodiacal light. If the particles have a rough surface, the phenomenon of the counter-glow can be theoretically accounted for. If the total mass of this ring of matter is appreciable, it will have an influence upon the motion of the planets. This question has been examined by Seeliger, who has shown that on the assumption that the density of the matter decreases with increasing distance from the Sun, it is possible to account for the acceleration of the motion of the perihelion of Mercury without introducing any appreciable discordances into the motions of the other planets. The amount of matter so required, as computed by Seeliger, has a mass about one-tenth of that of the Earth. The plausibility of this explanation is discounted by Crommelin's study of the motion of comets with small perihelion distance. The five comets considered emerged from the region near the Sun with no appreciable loss of velocity: from the manner in which meteors become incandescent on entering the Earth's atmosphere at a height of 100 miles, it follows that the comets could never get past the Sun if the density of the matter responsible for the zodiacal light at all approached that of the Earth's atmosphere

at a height of 100 miles. The actual density of the matter must be but a very small fraction of this amount. It therefore appears as though this matter cannot be held to give a satisfactory explanation of the acceleration of the perihelion of Mercury.

CHAPTER XII

THE STARS

177. WE have hitherto been dealing with the various members of the solar system. We have now to consider the bodies which to the ancients were known as the "fixed stars." They were so called because they apparently did not alter their positions with respect to one another, in contrast to the wandering stars or planets. We now know that the smallness of their apparent motions is due solely to their great distances, the distance of the nearest star at present known being about 260,000 times the distance of the Sun from the Earth. But the ancients had no knowledge of stellar distances, nor was there then any means by which they could determine them. In the sixteenth century, Copernicus was able to infer that their distances must be very great because they did not reflect the annual motion of the Earth about the Sun ; this was, however, used by his opponents as an argument against the theory rather than as a proof of the great distance of the stars. That the so-called fixed stars were, at least in some instances, not actually fixed was first proved by Halley, who, in 1718, showed that the bright stars Sirius, Procyon, and Arcturus were gradually changing their positions with reference to the neighbouring stars. The apparent relative displacements are so small even in the course of centuries that the appearance of the constellations of bright stars does not appreciably alter in the course of thousands of years ; the constellation of Orion has the same configuration to-day that it had several thousand years ago to the writer of the Book of Job.

178. **Stellar Constellations and Names.**—The stars were divided by the ancients into groups or constellations, to which were given names of persons or objects famous in olden

mythology. In a few cases a fanciful resemblance may be seen between the outline of a constellation and the object from which it derives its name, but in general no resemblance can be seen nor can any reason be assigned for the name. The division of the sky into constellations in this way was probably made for reasons of convenience; at a time when there were no instruments by which accurate positions might be assigned, the division facilitated the description of the sky and was an aid to remembering the number and arrangements of the stars. It is therefore not surprising that several peoples, including the Babylonians, Chinese, and Egyptians, divided the sky into constellations.

The oldest document in which is to be found a description of many of the constellations as known to-day is one by Eudoxus (409 to 326 B.C.) in which each figure is described together with the positions of the principal stars. Ptolemy's star catalogue divided the stars into forty-eight constellations, twelve in the zodiac, twenty-one to the north, and fifteen to the south. Some of these constellations have since been modified and others have been added from time to time, particularly in the neighbourhood of the south pole. The total number of constellations now generally recognized is eighty-eight.

A knowledge of these constellations and of the names and positions of the brighter stars in them is valuable. On several occasions, the appearance of a bright new star has been detected by persons thoroughly familiar with the aspect of the constellations who have at once noticed the changed appearance due to the outburst of the new star. For acquiring this familiarity, the study of the sky at different seasons of the year with a good star atlas is essential.

Individual stars are designated in various ways. Most of the brighter stars have names of their own of Greek, Latin, or Arabic origin, but the names of only some fifty or sixty stars are in common use, many of the fainter naked-eye stars having Arabic names which are practically obsolete. Bayer, in 1603, in the star maps of his *Uranometria*, was the first to adopt the plan of designating stars by the name of the constellation, prefixed by the letters of the Greek alphabet, usually assigned in the order of magnitude. Thus Polaris, the brightest star in the Little Bear, is α Ursæ Minoris; Arcturus, the brightest

star in Boötes, is α Boötis; Aldebaran, the brightest star in Taurus, is α Tauri, etc. The next brightest star would have the prefix β and so on. When the letters of the Greek alphabet have all been assigned, the letters of the Roman alphabet or the numbers assigned by Flamsteed are used, so that every naked-eye star has some letter or number in its constellation by which it may be identified.

In the case of the fainter stars it is convenient to have an easy means of identification and it is usual to refer to such a star by its number in a well-known star catalogue, usually the first important catalogue in which its place is given. Thus, a star might have the designation Lalande 45,585, indicating that it is No. 45,585 in Lalande's star catalogue (1790), or Groombridge 990, indicating that it is No. 990 in Groombridge's catalogue (1810). The majority of the stars down to a limit between the ninth and tenth magnitudes can thus be designated.

If a star cannot be designated in this way, it is necessary for its identification to give its place (i.e. its right ascension and declination) at a definite epoch. The purpose of a star catalogue is to give the places of a number of stars for a definite epoch. The observations for these catalogues are made with the meridian circle. Certain brighter stars for which accurate positions have first been determined are adopted as fundamental stars and the positions of the other stars are based upon these. The star catalogues usually give also for each star the values of the precession in right ascension and declination and of its secular variations, so that the position of the star at any desired epoch may readily be computed.

179. Stellar Magnitudes.—The relative brightness of different stars is indicated by a number, termed the star's magnitude. The conception of the magnitude of a star dates back to the time of Hipparchus, although it is only within recent years that precision has been given to the notion. Hipparchus selected about twenty of the brightest stars which he could see and called them first-magnitude stars. All the stars that he could just see he called sixth-magnitude stars. Stars of intermediate luminosity (by which we refer to apparent and not to intrinsic brightness) he placed in intermediate

classes, thus obtaining a somewhat rough and purely arbitrary classification. Ptolemy carried this classification a stage further, recognizing gradations in brightness between adjacent classes; these he recognized by attaching the words *μελζων* (greater) and *ἐλάσσων* (less) to the magnitudes, to denote that it was somewhat brighter or fainter than that magnitude. He therefore practically divided each class into three. The decimal division of the magnitude intervals was first used by Argelander and Schönfeld in the preparation of the extensive survey of the sky known as the Bonn Durchmusterung or B.D. Thus, a star whose magnitude was assigned as 8.3 was intermediate between magnitudes 8 and 9, but judged to be only three-tenths of the interval fainter than 8. This method of denoting magnitudes has been adopted and extended in the modern more precise magnitude determinations.

The question arises as to what this arbitrary magnitude classification corresponds to in terms of apparent brightness. It was not until the time of Sir John Herschel that attention was given to this question; Herschel concluded that a decrease of light in geometrical progression corresponded to an increase of magnitude in arithmetical progression and estimated that the actual ratio of the light of a star of the first magnitude to one of the sixth is at least 100 to 1.

Herschel's conclusion is in accordance with a physio-physical law enunciated by Fechner in 1859 that as a stimulus increases in geometrical progression, its resulting sensation increases in arithmetical progression. If then I_1, I_2 denote the brightness of two stars whose magnitudes are m_1 and m_2 , a relationship must hold of the type

$$\frac{I_1}{I_2} = k^{m_2 - m_1}$$

where k is a constant quantity denoting the ratio in the brightness of stars of consecutive magnitudes. Adopting Herschel's estimate that if $m_2 - m_1$ is 5 magnitudes, $I_1/I_2 = 100$, we have $100 = k^5$ or $\log k = 0.4$, so that $k = 2.512 \dots$ Now the magnitudes assigned in the Bonn Durchmusterung and other early catalogues, which for the naked-eye stars fit in closely with previous estimates of magnitude extending back to the time of Hipparchus, agree very closely with this value of the "light-

ratio," as the quantity k is termed. Pogson therefore suggested that k should be definitely adopted as the quantity $2.512 \dots$ whose logarithm is 0.4 ; a star of one magnitude is then about 2.5 times as bright as one of the next lower magnitude and a difference of five magnitudes corresponds exactly to a ratio in brightness of $100 : 1$.

The adoption of this value for k gives logical precision to the conception of magnitude and is sufficiently in accordance with old estimates to avoid serious discontinuity. Modern determinations of visual magnitudes are based upon this ratio and the zero of the scale is adjusted so that the mean magnitude of stars near the sixth magnitude agrees with the mean value of the magnitudes assigned to these stars in the Bonn Durchmusterung. In this way, extensive determinations of visual magnitudes have been made at Harvard and Potsdam which are available for fixing the zero of the scale in future determinations.

Logically, the scale of magnitudes can be continued without limit in both directions. Thus stars which are one magnitude brighter than stars of the first magnitude are said to be of magnitude 0 and still brighter stars have a negative magnitude. Thus, the magnitude of Sirius, the brightest star, is about -1.4 , whilst on the same scale the magnitude of the Sun is -26.7 .

180. Photographic Magnitudes.—With the development of photographic methods in astronomy, it was natural to attempt the determination of stellar magnitudes by photographic methods. Stars of different brightness produce images of different sizes on the photographic plate and the size of the image may be used as the basis of magnitude determination. Photography has the advantage of economy of time at the telescope, since when the plates have been obtained they may be measured at leisure. It also enables fainter magnitudes to be reached, since, by lengthening the exposure, the plate continues to respond to the stimulus of the incident light and gives an integrated effect, which the eye is not able to do.

But since, as compared with the eye, the photographic plate is relatively more sensitive to the blue end of the spectrum and

less sensitive to the red end, it follows that if two stars, one of which is blue and the other red, are of equal visual magnitude, their photographic magnitudes will not be equal, but the blue star will appear photographically the brighter. The difference photographic *minus* visual magnitude therefore provides a criterion as to the colour of the star and is called its "colour index." The zero of the photographic scale of magnitudes is adjusted so that for stars of the sixth magnitude of the Harvard type *A0* (see § 189), i.e. for bluish stars in whose spectrum the hydrogen series $H\alpha$, $H\beta$, etc., reaches its greatest intensity, the photographic and visual magnitudes are equal. The same light-ratio is adopted for photographic as for visual magnitudes, so that for any star of type *A0* the photographic and visual magnitudes are equal. Of recent years, by employing isochromatic plates in conjunction with a yellow filter, magnitudes have been determined photographically which correspond very closely with visual magnitudes, the sensitivity curve of the isochromatic plate under these circumstances being similar to that of the eye. Magnitudes so determined are termed photo-visual. By proceeding in this way, the scale of visual magnitudes can be extended to much fainter stars and the magnitudes can be determined with less labour.

As an illustration of the difference between photographic and visual magnitudes, reference may be made to Plate XXIII. The two large star images are those of α and β Crucis, two bright stars in the Southern Cross. Both these stars are blue stars. On a level with α Crucis, the star nearer the top of the plate and near the left-hand edge of the plate is a much smaller star image. This is the image of γ Crucis, a very red star, which visually is of the same brightness as β Crucis.

181. Determination of Visual Magnitudes.—Visual magnitudes are determined with an instrument called a photometer, of which there are several different types. The two best types are perhaps the Zöllner and meridian photometers, which were used for the extensive series of magnitude determinations at Potsdam and Harvard respectively. A brief description of these two instruments will suffice to illustrate the general principles of visual magnitude determination.

In the Zöllner type of photometer, the star under observation

is compared with the image of an artificial star whose brightness can be varied at will until equality between the two images is obtained. An arm is attached to the telescope tube at right angles to its axis (Fig. 87) and at the end of this arm is a small pinhole diaphragm *o*, through which passes light from a petroleum or other type of standard lamp giving constant illumination. The size of the aperture *o* can be varied to

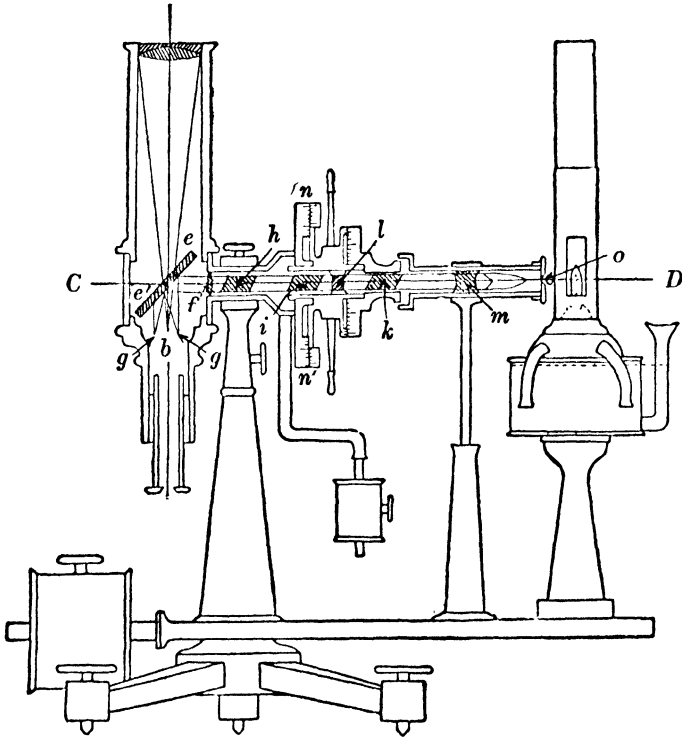

FIG. 87.—The Zöllner Photometer.

simulate stars of different magnitudes. The divergence of the rays is increased by a double concave lens, *m*, and they then fall upon a Nicol prism, *k*, which polarizes the light, i.e. permits only the vibrations in one definite plane to pass through. On emergence from the Nicol prism, the light passes through a crystal of quartz, *l*, cut perpendicularly to its axis and a second Nicol *i*, so that by rotating the first Nicol relatively to them, the

colour of the artificial star can be varied so as to produce approximate equality with that of the star under observation. The light then falls upon a third Nicol prism, h , which acts as an analyser. By rotating the system containing the Nicols k , i and the plate l , the Nicol h remaining fixed, the light emerging from the latter is varied in intensity, its colour meanwhile remaining the same; the intensity of the emergent light is proportional to the square of the sine of the angle between the principal sections of the two prisms i and h . The light then falls on a double convex lens, f , which brings it to a focus in the focal plane of the telescope, after reflection from a plane unsilvered glass plate ee' . Two images g, g of the artificial star are formed by reflection at the front and back surfaces respectively of the mirror. To find the magnitude difference between two stars, therefore, the image of the artificial star is brought into equality with the two star images respectively, and if θ_1, θ_2 are the angles through which the Nicol i is turned in the two cases, the ratio of the brightness of the two stars is $\sin^2\theta_1/\sin^2\theta_2$ and therefore their difference in magnitude is $2.5 \{ \log \sin^2\theta_1 - \log \sin^2\theta_2 \}$. There are four positions in which equality of light is produced, the reading corresponding to each being taken and the mean value used. The principal disadvantage of this type of photometer is the use of an artificial star, whose image is not absolutely comparable under conditions of average atmospheric definition to that of a real star; this causes a liability to personal errors in observation.

The meridian photometer of Pickering consists of a telescope with two similar object glasses side by side (A and B) and of the same focal length (Fig. 88). It is placed in a horizontal position, and in front of each object glass is a right-angled prism (C, D) which serves as a mirror to reflect into the tube the light from stars on or near the meridian. One of these mirrors, D , is capable of slight adjustments by means of the rods E and F , so as always to send the light from the pole star into the lens, whilst the other, C , can be turned about an axis so as to reflect light from any star on or near the meridian into the second lens. The position of the mirror, C , is given by the graduated circle G . The beams of light from the two objectives fall upon a double-image prism, K , of Iceland spar, compensated by glass; each beam is split up into two beams, polarized at right angles

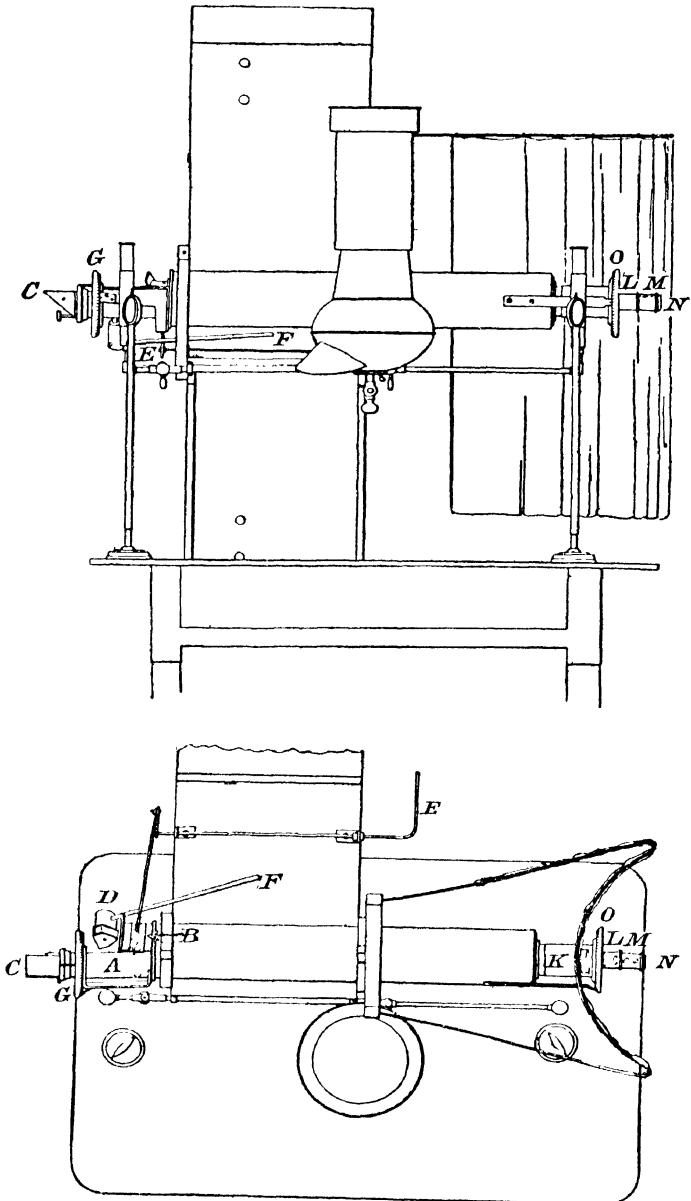

FIG. 88.—The Meridian Photometer.

to one another. A diaphragm is so placed as to cut off the extraordinary beam from the one objective and the ordinary beam from the other, allowing the other two beams which are polarized at right angles to unite and to pass through the eyepiece, L . The beam then falls on to a Nicol prism, M , which can be rotated, and then through the eyestop, N , to the observer's eye. By rotating the Nicol the relative intensities of the two beams can be varied, causing a corresponding variation in the two images in the focal plane of the eyepiece. If θ is the angle through which the Nicol is turned from the position in which the image of Polaris disappears to that in which equality between the two images is obtained, and if I_0 , I are the brightnesses of Polaris and the other star respectively, then when the images are equal

$$I_0 \cos^2\theta = I \sin^2\theta$$

and the difference in magnitude of the two stars is $2.5 \log \tan^2\theta$ or $5 \log \tan \theta$. As in the case of the Zöllner photometer, there are four settings for which equality can be obtained, and the position of each is observed. This photometer has the advantage that two star images are directly compared, but has the disadvantage that observations can only be obtained on or near the meridian and that the images are produced by different optical trains. It does not provide any means of compensating for colour, and personal and subjective errors of considerable magnitude may enter when the brightness of images of different colours are compared; this is due to a phenomenon called the Purkinje effect—if two sources of light, one red and the other green, appear of equal brightness and the intensity of each is increased on the same ratio, the red light will appear the brighter; if the intensity of each is decreased in the same ratio, the green will appear the brighter. Also the relative sensitiveness of the eyes of different persons to light of different colours are not the same, so that it is not surprising that series of observations by different observers, even with the same instrument, show at times somewhat large discordances depending upon colour and magnitude. The subjective effect of the eye cannot be entirely eliminated and it is best to take the mean values obtained by several observers.

It will have been noticed that the photometer determines only differences of magnitude and therefore the zero of the magnitude

scale must be fixed before the magnitudes can be made absolute. As previously explained, the zero is fixed by adjusting the magnitudes so that in the mean they agree with those in the B.D. at about the sixth magnitude.

There are other types of photometer, such as the wedge photometer. In this type, a wedge of dark neutral-tinted glass is used, through which the star is viewed. The position of the wedge is found for which the star just disappears. This type of observation, besides being extremely fatiguing to the eye, depends upon the retinal sensitiveness at the moment of observation, and the wedge photometer has not therefore been greatly used.

With any type of photometer, the magnitudes determined must be corrected for the absorption of light in the Earth's atmosphere. The lower the altitude of the star at the moment of observation, the longer the path of the light from it in our atmosphere and the greater the absorption. By observing the same star at different altitudes or otherwise it is possible to deduce a correction depending upon altitude, so that the magnitude can be corrected to the value it would have if the star were observed in the zenith. All magnitude observations should be corrected in this way.

182. Determination of Photographic Magnitudes.—The determination of magnitudes photographically proceeds upon rather different lines. It is somewhat complicated by the laws of photographic action. The intensity of the image produced on a photographic plate by a given stimulus is not proportional to the time of exposure but follows a more complex law. All comparisons must therefore be made *viâ* exposures of the same length. It is advisable also that only images on the same plate should be compared, so as to avoid possible errors arising from slight differences in the sensitivities of the plates or in their treatment during development. The principle of the method by which photographic magnitudes are determined is to give one exposure on the field of stars under investigation and then a second exposure in which the intensities of the light falling on the plate from all the stars have been reduced in the same ratio and therefore by a definite magnitude interval. In the case of a reflecting telescope, this reduction can be most

easily effected by reducing the aperture, the light falling on the plate being then reduced proportionally to the area of the aperture ; with a refractor, this method would introduce errors, as it would modify the proportion of light absorbed in the object glass, the central portion being thicker than the edge. With either type of telescope, the reduction may be effected by means of a fine wire-mesh screen whose absorption must be determined in the laboratory. Another method is to place over the objective a grating composed of a number of parallel equidistant wires. Such a grating, in use at the Royal Observatory, Greenwich, is shown in Plate XVII (*a*). Each star image then consists of a central image, with a series of diffraction images on either side of it extending along a direction perpendicular to the direction of the wires, as illustrated by Plate XVII (*b*). By a suitable choice of the diameter of the wire and of the intervals between adjacent wires, the first diffracted image on either side of the central image will be round and will differ in magnitude from the central image by a desired amount, which should not exceed four magnitudes, and which can be calculated from the dimensions of the grating. This method has the great advantage that the two images of any one star, differing by a known magnitude, are obtained with one exposure, so that errors which might arise from any variation in the transparency of the sky during the exposures for any one plate are avoided.

Having the plate with the two series of images differing by a known magnitude, suppose an image of one star in the first series is equal to that of another star in the second series ; then the magnitude difference of these stars is obviously equal to the constant difference between the two series. In practice, both series of images are compared with a set of images of a single star, photographed with the same telescope with exposures so adjusted as to give approximately equal difference in magnitude between successive images. The magnitude of each image can be estimated on this arbitrary scale by comparing them in a micrometer and the scale can then be standardized from the known magnitude differences of the two images of each star.

In this way, differences of magnitude only are determined and the zero must be adjusted so that for stars of type A0 the photographic magnitudes agree with the visual magnitudes.

183. Numbers of Stars of Different Magnitudes.—The numbers of stars in the whole sky down to various limits of magnitude from the second to the tenth are given in the following table, for both visual and photographic magnitudes. The data for the visual magnitudes were obtained at Harvard, and those for the photographic at Greenwich:—

Magnitudo Limit.	Number of Stars.	
	(Visual.)	(Photographic.)
2	41	38
3	138	111
4	454	300
5	1,480	950
6	4,750	3,150
7	14,960	9,810
8	45,710	32,360
9	134,000	97,400
10	373,000	271,800

The limit of magnitude visible to the average eye is somewhere between 6 and 7, so that approximately about 10,000 stars in the whole sky are within the reach of the naked eye. Not more than about one-third of these can probably be seen at any one time. This number is much smaller than is generally popularly supposed.

184. Total Light of the Stars.—The equivalent light of the stars of different magnitudes in terms of first-magnitude stars can easily be calculated. On the photographic-magnitude scale, the three brightest stars, Sirius, α Carinæ, and α Centauri, are equal respectively to 11, 6, and 2 first-magnitude stars. The eight stars between magnitudes 0 and 1 are equal to 14 first-magnitude stars and so on. The greatest light from stars within one magnitude interval is between magnitudes 9.0 and 10.0, the total light from the 174,000 stars within this range being equal to that of 69 first-magnitude stars. For fainter stars, the increase in total number is not sufficient to compensate for the decrease in brightness, and the total equivalent

light from stars with a range of one magnitude continuously decreases. The equivalent light of all the stars is equal to that of about 700 first-magnitude stars (photographic) or of about 900 to 1,000 first-magnitude stars (visual). The photographic magnitude of the full Moon has been found to be -11.2 , and from this it follows that the full Moon gives 100 times as much light as all the stars together. Another way of expressing the results is that the total star light is equal in photographic intensity to that of an ordinary 16-candle-power lamp at 47 yards distance.

185. Proper Motions of Stars.—That the stars have motions of their own was first shown by Halley. The real motion of any star may be along any direction in space, but it is only that component of the motion of any star which is at right angles to the line of sight which will cause an apparent displacement of the star on the celestial sphere relative to other stars. This component of the motion, expressed in angular movement per year or per century, is called the proper motion of the star. It is actually a combination of the angular displacements resulting both from the actual motion of the star and from the actual motion of the Sun.

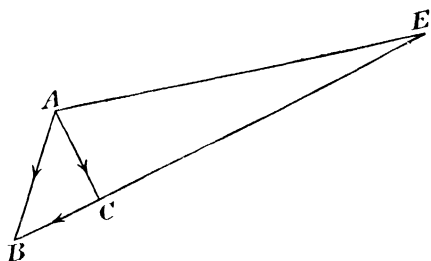

FIG. 89.—Proper Motion.

Thus, in Fig. 89, if E is the position of the Earth, and A and B represent the positions relatively to the Earth of the star at the beginning and end of a year, then AB represents the real relative motion of the star in a year, AB being very small compared with the distance AE . AB may be split into the two components, CB along the line of sight and AC at right angles to it. The angle AEB is the angular displacement of the star upon the celestial sphere due to the component AC of its proper motion, i.e. it is the annual proper motion of the star.

For a given real velocity, the angular velocity will be greater the nearer the star. A large proper motion is generally to be

ascribed to the star being relatively near rather than to an intrinsically large velocity. The brighter stars are on the average nearer than the fainter ones and therefore have on the average larger proper motions. The largest proper motion known at present is that of a faint star of magnitude 9.4 m, known as Munich 15,040. This star, which is known also as Barnard's proper-motion star, has an annual proper motion of $10''.29$. The next largest motion known is that of a star of magnitude 8.0, known as Cordoba Zones, 5 hours, No. 243, which has an annual proper motion of $8''.75$. Other large proper motions are:—

	Mag.	P.M.		Mag.	P.M.
		"			"
Groombridge 1,830	6.4	7.03	Lalande 21,258	8.5	4.49
Lacaille 9,352	8.7	6.89	α_2 Eridani	4.5	4.08
Cordoba 32,416	8.3	6.11	μ Cassiopeiae	5.3	3.75
61 Cygni	5.4	5.24	Argelander 11702	9.2	3.72
Lalande 21,185	7.3	4.74	α Centauri	0.2	3.68
ϵ Indi	5.2	4.67	Lacaille 8,760	7.3	3.44

A proper motion of $10''$ annually would carry a star through 360° in about 130,000 years. The number of stars with proper motions known to exceed $1''$ per year is about a couple of hundred.

Proper motions of stars can be deduced by comparing the positions given in star catalogues whose epochs differ preferably by at least fifty years. In making the comparison, the effect of precession on the star's right ascension and declination between the two observations must be allowed for. For most of the brighter stars, positions may be found in several catalogues. In the case of faint stars, for which early observations are not available, proper motions can be obtained with a fair degree of accuracy by comparing photographs obtained at an interval of about twenty years.

If the distance of the star is known (AE in Fig. 89) the proper motion can be converted into linear motion.

186. Line-of-Sight Velocity—The component of the velocity of the star in the line of sight (BC in Fig. 89) can be determined by measuring the displacement of the lines in the

spectrum of the star produced by the motion. This method was first used visually by Sir William Huggins in 1867. The principles involved have already been explained in § 69. Determinations of line-of-sight velocity are now always made photographically. The spectrum of the star is photographed with the aid of a spectrograph attached to the eye end of the telescope, and a suitable comparison spectrum of a terrestrial source is photographed with the same spectrograph on the same plate, with the aid of which it is possible to determine directly the displacements of many of the lines. The displacement is measured accurately in a micrometer. Special precautions must be taken in the observations to avoid temperature changes by insulating the spectrograph.

The line-of-sight velocity is determined directly in miles or kilometres per second. The accuracy of modern observation is very great; provided the spectral lines are sharp, a probable error of under $\frac{1}{4}$ mile per second can be obtained. Velocities greater than 50 miles per second are relatively few. The greatest yet observed is that of Lalande 1,966, with a velocity of 203 miles per second. The star Cordoba Zones 5 h. 243, which has the large proper motion of $8''.75$, has also a large line-of-sight velocity of 151 miles per second.

187. Solar Motion.—The observed motions of the stars are their motions relative to the Earth, the motion of which is in turn a combination of its orbital motion about the Sun and the motion of the Sun itself. The apparent displacements of stars on the celestial sphere due to the orbital motion of the Earth are small and oscillatory, whilst the influence of the

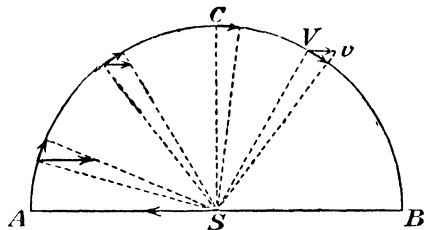

FIG. 90.—Effect of Solar Motion on Proper Motion of Stars.

orbital velocity on the line-of-sight measurements can be allowed for and the observations reduced to an observer on the Sun. We need therefore consider only the combination of the real motions of the star and the Sun.

Suppose first that the stars have no real motions and that

the Sun is in motion directly towards a point A on the celestial sphere and away from the diametrically opposite point B (Fig. 90). Then, in small regions of the sky around A and B respectively, the stars will show no proper motions, since the relative velocity is along the line of sight in each case. Any star in a direction at right angles to AB has a relative motion, on the other hand, which is entirely at right angles to the line of sight, and the motion will appear as a proper motion of the star along a great circle passing through A and B and in the direction towards B . The stars near A , therefore, appear to be opening out, those near B to be closing in. The proper motion will be greater the smaller the distance of the star from the Sun, and the nearer the angular distance of the star from A approaches 90° . If V is any star, at a distance R from the Sun in a direction SV making an angle θ with SA or SB , and if D is the distance through which the Sun moves in one year in the direction SA , the relative displacement of the star will be $Vv = D$ parallel to SB and its angular displacement on the celestial sphere, obtained by dividing the projection of Vv by the distance SV , will be $D \sin \theta / R$. This will be the observed proper motion of the star.

But this simple result is complicated by the intrinsic motions of the stars and by their varying distances. If, however, a sufficiently small area of the celestial sphere be considered, and the proper motions of the stars in this area be determined, it may be assumed that since the real motions occur in all directions at random they will average zero when the mean is taken. If stars of a limited range of magnitude are used, their distances will cluster about a certain mean value and the mean observed proper motion for the group will be $D \sin \theta / R$, where R is the mean distance of the group.

Sir William Herschel was the first to notice that the stars in one region of the sky were apparently separating from one another and that those in the opposite region were closing in, as shown in Fig. 90. He interpreted this as due to solar motion and used the result to determine the direction of the Sun's motion. That this interpretation is correct is confirmed by the radial-velocity observations. The mean radial velocity of stars near A should be towards S and that of those near B should be away from S , the mean values being equal. At C ,

on the other hand, the solar motion does not affect the line-of-sight velocity, and the mean value of a sufficiently large group of stars should be zero. At an intermediate point, the mean value should be proportional to the cosine of the angle between the direction to the star and AB . These results are confirmed by the observations, which prove also that the Sun has a velocity of about 13 miles per second towards a point with right ascension approximately 270° (18 hours) and declination $+30^\circ$, in the constellation of Hercules. This point is called the *Solar Apex*. The point from which the Sun is moving, i.e. the point on the celestial sphere diametrically opposite to the solar apex, is called the *Solar antapex*.

Using the value so obtained for the velocity of the solar motion, D the distance described by the solar system in a year can be determined and then from the mean value of the proper motions for a group of stars can be deduced the mean value of $1/R$ or, alternatively, the mean parallax of the group of stars. This method is frequently used for the determination of the mean distances of groups of stars.

188. **Star Streams.**—In discussing the solar motion in the preceding section, it was assumed that the real motions of the stars in a sufficiently small area were in random directions. In 1904 it was shown by Kapteyn that this is not exactly so, but that there is a peculiarity in the stellar motions which causes the stars to move in two favoured directions. If we consider the stars in a limited area and count the number of stars observed to be moving in different directions, say from 0° to 10° , 10° to 20° , 20° to 30° , etc., the angle being measured from

the north through east, the results can be plotted on a polar diagram, the radius vector in a given direction being proportional to the number of stars moving in that direction. If the motions were at random, the curve would be a circle if there were no solar motion. The effect of the latter is to superpose on the real motions an apparent motion in the

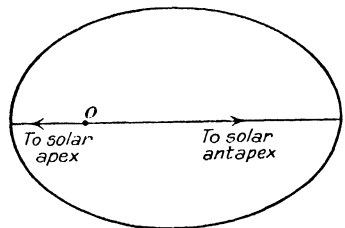

FIG. 91.—Distribution of Proper Motions due to Single Drift Motion.

opposite direction ; there will therefore be a maximum number of stars apparently moving in the direction opposite to that of the motion of the Sun and a minimum number with it. The curve representing the observed distribution would therefore be an oval (Fig. 91), symmetrical about the great circle through the solar apex and antapex and with its greatest elongation towards the antapex. The curves actually obtained are not of this simple nature but are of a more complex type. They show, in general, two favoured directions of motion instead of a single one, and in every case it is found that they

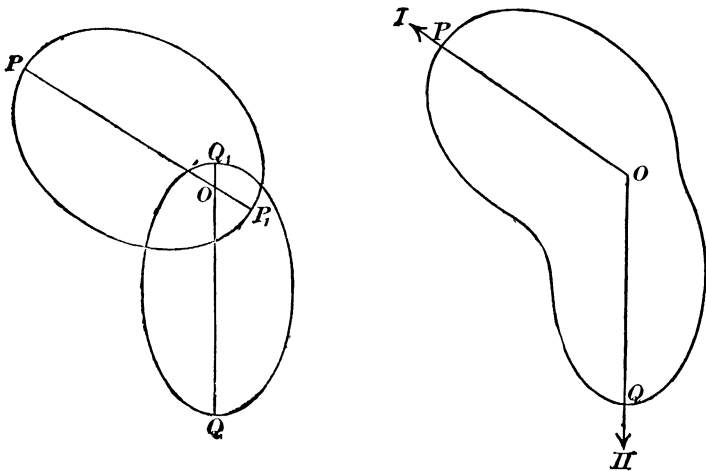

FIG. 92.—The Combination of two Single Drift Motions.

can be represented within the limits of error of observation by the superposition of two simple diagrams of the type discussed. This is represented in Fig. 92. The directions OP , OQ , are the two favoured directions of motion, and the combination of the effects produced by two simple drifts gives a distribution of proper motions represented by the curve on the right-hand side of the diagram. If similar curves are constructed for different regions of the sky, using the observed proper motions, and the directions OP , OQ thus determined are continued across the celestial sphere as great circles, it is found that these circles intersect one another, within the limits of error, in two distinct points ; this indicates that the two favoured directions are for

every region of the sky towards the same two points on the celestial sphere and represent real drifts of the stars. One of these points is at R.A. 90° , Dec. -15° , and the other at R.A. 285° , Dec. -64° . It is further found from the mathematical analysis that the first of these drifts contains about 60 per cent. of the stars and the second about 40 per cent. and that the speed of the first drift is about double that of the latter.

These motions are, of course, measured relative to the Sun. In Fig. 93 suppose that SA and SB represent the drift velocities; then if AB is divided at C so that $AC : CB = 2 : 3$, i.e. in the proportion of stars in the drifts SB and SA respectively, SC will represent the motion of the centroid of the stars with reference to the Sun. CS must

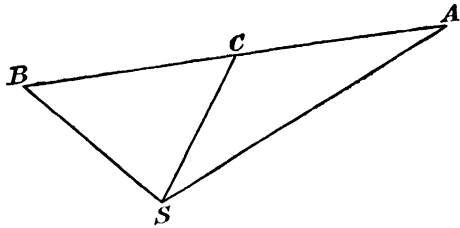

FIG. 93.—Star-streaming and Solar Motion.

therefore represent the solar motion and point towards the solar apex whilst AB represents the velocity of the one drift relatively to the other. The points on the celestial sphere towards which the line AB is directed are called the *vertices*; their positions are approximately R.A. 95° , Dec. $+12^\circ$, and R.A. 275° , Dec. -12° . These points fall exactly in the plane of the Milky Way.

Viewed in this way, it is evident that the inclination of the directions of the two stream motions, illustrated by Fig. 92, is due to the fact that the observed motions are a combination of the real motions entangled with the solar motion. Actually the directions of motion of the streams are opposite to one another in space. It is evident, in fact, that if there exist two streams of stars moving relatively to one another in space, all that can possibly be learnt about their motions is the direction and magnitude of their *relative* motion. From this point of view, it is clear that the phenomenon of star-streaming indicates the existence of a direction which is of fundamental importance in connection with stellar motions and about which the motions are symmetrical.

Schwarzschild emphasized this aspect of the matter and

pointed out that the observed phenomenon can be explained by supposing that the stars have a greater freedom of movement in a certain direction (the line joining the vertices) than in perpendicular directions. From this point of view the separation of the stars into two separate streams is not essential to the explanation of the observed distribution of the proper motions, although, of course, this method of representation does not deny and is not in variance with the tendency of the proper motions in any region to favour two definite directions.

Observations of line-of-sight velocities are also in accord with the phenomenon of star-streaming, the radial velocities after eliminating the component due to the solar motion showing a distinct tendency to be greater near the vertices than elsewhere.

189. Spectral Types of Stars.—The spectrum of a star consists in general of a continuous emission spectrum upon which is superposed a discontinuous absorption or emission spectrum. Different stars give spectra which differ very considerably *inter se*, but Secchi, who was the first to examine stellar spectra on a considerable scale, found that the spectra could be classified into four broad classes, and that this classification was practically a classification according to the colour of the star. Secchi's classification has now been practically superseded by that of the Draper Catalogue of the Harvard Observatory; about a quarter of a million stellar spectra have been classified at Harvard. This classification forms a single continuous linear sequence, successive classes being denoted by the letters, O, B, A, F, G, K, M, N, R, the order in which the letters are here given being connected with the successive stages of the evolution of a star. At present it is sufficient to state that it is believed that a star in the course of its evolution passes through successive stages, which are characterized by these spectra. Each class is further subdivided, these subdivisions being indicated by letters in the case of types O and M, thus Ob, Ma, etc., and by figures (representing a decimal subdivision) in the case of types B, A, F, G, K, thus B9, A0, F8, G5, K2, etc. The following is a brief description of the types :—

Type O.—The spectrum consists of a faint continuous background upon which are superposed bright bands. No dark

bands occur except in the subdivisions Od, Oe, and are then due chiefly to hydrogen and helium. In the subdivisions Oa, Ob, and Oc the hydrogen and helium lines are bright. Bright bands at wave-lengths 4633 and 4686 are present in all subdivisions except Oe5. Stars of type O with bright bands are often called Wolf-Rayet stars.

Type B.—Stars of this type are sometimes called Orion or helium stars. The spectra of this type contain only dark lines, of which the helium lines are the most prominent; they reach their maximum intensity in the subdivision B2 and in later subdivisions become gradually less prominent, finally practically disappearing in B9. At the same time the intensity of the hydrogen lines gradually increases. In B8, some lines which occur in the solar spectrum appear for the first time. The H and K lines of calcium are present but not prominent.

Type A.—The most prominent feature in the spectra of this type is the great intensity of the hydrogen lines, which reach a maximum in A2. Helium is absent. The H and K lines of calcium increase in prominence throughout the type. The magnesium line of wave-length 4481 is prominent, and other metallic lines begin to appear in the early subdivisions and grow progressively stronger, becoming the chief feature in class A5.

Type F.—In this type, the intensity of the hydrogen lines diminishes and the metallic lines increase in prominence. The H and K lines are very prominent. The spectrum is gradually approaching that of the Sun.

Type G.—The solar spectrum is a typical example of a type G spectrum. Numerous metallic lines are present and are as conspicuous as the hydrogen lines. The H and K lines of calcium are the most prominent feature. The increased absorption at the blue end of the spectrum gives the stars a yellow colour.

Type K.—In this type, the hydrogen lines are much less prominent and the relative intensity of the blue end of the spectrum becomes appreciably less. Bands due to hydrocarbons appear for the first time.

Type M.—This type is characterized by broad absorption bands which have their greatest intensity towards the violet end. The solar lines decrease in number and intensity. Bands due

to titanium oxide are very prominent. Sub-type Md is a special subdivision, in which bright hydrogen lines reappear. All stars of this sub-type are long-period variables.

Type N.—Stars of this type have broad absorption lines in their spectra which are most intense towards the red. These lines are mostly due to carbon monoxide and to cyanogen. A few bright lines may be present. All the stars of this type are very red.

Type R.—This is a small class of stars which are not so red as stars of types M and N, although the most prominent absorption bands of type N are present.

The characteristics of stars vary so much with spectral type that a knowledge of the type is of fundamental importance in all discussions connected with the physical state of a star.

190. Spectral Type and Colour-Index.—We have seen in the preceding section that the recognized classification of stars according to the nature of their spectra is also a classification according to colour, the O, B, A or early-type stars being blue, the stars of intermediate type, F, G, K, yellow, and the late, type stars, M, N, etc., red. The colour of a star was defined in § 180 by means of its "colour-index" or the difference between photographic and visual magnitudes. A comparison between colour-index and spectral type is therefore suggested. In the following table the average colour-index for stars of different spectral types, as determined by King and Parkhurst, is given:

Spectral Type.	Colour-index according to—	
	King.	Parkhurst.
	m.	m.
B0	- 0.31	- 0.48
A0	0.00	- 0.06
F0	+ 0.32	+ 0.40
G0	+ 0.71	+ 0.86
K0	+ 1.17	+ 1.32
M	+ 1.68	+ 1.77

It will be seen from this table that the increase in colour-index from type to type is in the mean practically uniform, so

that a knowledge of the colour-index of a particular star is sufficient to determine its spectral type with a fair degree of accuracy, and *vice versa*.

191. Effective Temperatures of Stars.—The effective temperature of a star is defined as the temperature of a perfect radiator, or black body as the physicist calls it, which has the same distribution of energy amongst different wave-lengths as the star. For a perfect radiator, there is a definite relationship between the energy radiated of any specified wave-length, the wave-length, and the temperature. For any given temperature, the curve connecting the spectral intensity with the wave-length is a smooth curve which has a single maximum of intensity for a certain wave-length, the intensity falling away for wave-lengths longer or shorter than this value. The wave-length corresponding to maximum spectral emission is inversely proportional to the temperature. By measuring the distribution of intensity throughout the spectrum of a star and comparing the smoothed intensity curve with the black-body curves, the effective temperature may be determined. The temperature so obtained may be higher or lower than the true value at the surface of the star, since the stars are not perfect radiators; but it is probable that the values so found are not greatly wide of the mark and there is no doubt that they express correctly the relative temperatures of different stars. The temperatures show a strong dependence upon spectral type, as is indicated by the following table in which the mean effective temperatures determined at Potsdam for stars of different type are given:—

Stellar Type.	Effective Temperature, °C
Oa	23,000
B0	20,000
B5	14,000
A0	11,000
A5	9,000
F0	7,500
G0	5,000
K0	4,200
Ma	3,100
N	2,950
R	2,300

These figures show that the temperatures of the blue stars are the highest and those of the red stars the lowest. The rate of change of temperature with spectral type and therefore also with colour is much more rapid at the beginning of the series than at the end.

The effective temperature of the Sun, which is a G-type star, is between $6,000^{\circ}$ and $7,000^{\circ}$. The mean value determined at Potsdam for this type is $5,000^{\circ}$. This value and the subsequent values in the table above are almost certainly somewhat too low.

192. Ionization in Stellar Atmospheres.—A physical explanation of this clearly marked relationship between effective temperature and the type of spectrum was given in 1921 by Saha. According to his theory, in fact, the temperature of the stellar atmosphere is the factor which, more than any other, fixes its spectrum.

If a gas, say a chemical compound, is gradually heated, a stage will arrive at which the molecules of the compound will be dissociated into the molecules of simpler compounds or of the constituent elements themselves. On still further heating, the molecules will in turn be dissociated or decomposed into atoms. The progress of these phenomena can be treated mathematically, using the principles of thermodynamics. If the gaseous mass consisting of atoms only be heated, Saha supposes that the outer electrons in the atom are gradually torn off: the energy of this ionization can be calculated by physical principles, and it then becomes possible to apply the reasoning of thermodynamics to the process. At any given temperature, a steady state will result if the temperature does not vary, in which there will be a definite degree of ionization and in which, on the average, as many electrons recombine with atoms as are dissociated from them. The extent of the ionization at any particular temperature for any given element can thus be calculated.

Now, spectroscopically, an ionized element can be distinguished from a unionized element, for the former shows lines in its spectrum which are called enhanced lines whose intensity is much greater than in the spectrum of the unionized element. It therefore becomes possible to correlate the intensities of

various enhanced lines of different elements with the temperature and pressure required to produce the necessary degree of ionization. This is the basis of the method developed by Saha ; from a study of certain lines in spectra of different types he has found it possible to derive the temperatures in the stellar atmospheres. The temperatures so deduced agree very closely, for types O, B, A, with those determined at Potsdam and given in the preceding paragraph. For types F0, G0, K0, and Ma, values of $9,000^{\circ}$, $7,000^{\circ}$, $6,000^{\circ}$, and $5,000^{\circ}$ respectively are obtained. These values are somewhat higher than those determined at Potsdam for the same types, but, as has previously been mentioned, the Potsdam values for the red stars are probably too low.

It may incidentally be mentioned that the theory also gives a satisfactory explanation of the occurrence of lines due to certain elements in the spectra of the Sun and stars and of the absence of lines due to other elements. It has for long been a puzzle why the lines of some elements should be so prominent, whilst those of other elements, which must almost certainly be present in the stars in large quantities, are either absent or relatively inconspicuous. It is, for instance, impossible to believe that stars of type O consist solely of hydrogen and helium. If a star passes through successive types in the course of its evolution, the elements whose lines appear in the later stages must also have been present in the early stages, although no lines which characterize their spectra were evident in the spectrum of the star at that time. The presence or absence of the lines due to any individual element is almost solely a question of the relative extents of the ionization of that element at the temperature prevailing in the stellar atmosphere. If the ionization is complete the ordinary lines will be absent, and the lines due to the ionized atoms may be far away in the ultra-violet. If, on the other hand, the ionization has not commenced, the enhanced lines will be absent. As an example, the yellow D lines of sodium are much more prominent in the spectra of Sun-spots than in the spectrum of the Sun's chromosphere. This is because the Sun-spots are at a lower temperature, so that there is less ionization, and the D lines, being due to non-ionized atoms, are therefore more prominent. The theory also gives a satisfactory expla-

nation of the relative heights at which different elements appear in the flash spectrum.

193. Measurement of the Distances of Stars.—The distances of stars are so great that it is customary, for convenience, to refer to the parallax of a star rather than to its actual distance. In speaking of a stellar parallax it is not the diurnal parallax that is referred to, but the annual parallax. The former is the angular semi-diameter of the Earth as seen from the body in question: this semi-diameter forms the natural base-line for the measurement of the distances of the members of the solar system. For the stars, on the other hand, the natural base-line is the semi-diameter of the Earth's orbit, and the parallax of a star is the angle which this distance subtends at the distance of the star. For no star is it known to be as great as 1 second of arc.

The unit of distance used for the convenient expression of the linear distance of a star is termed a *parsec*, and is that distance which corresponds to a parallax of 1 second of arc. Parallaxes of $0''\cdot1$, $0''\cdot01$, $0''\cdot001$, etc., therefore correspond to distances of 10, 100, 1,000 . . . parsecs respectively. Another unit which is frequently used in popular language is the *light-year*, i.e. the distance which light (whose speed is 186,000 miles per second) travels in one year. The light-year is about 63,000 times the distance of the Earth from the Sun. The scientific unit, the *parsec*, is equal to 3·26 light-years.

It is owing to the smallness of stellar parallaxes that attempts to measure them were for so long unsuccessful. It was not until 1838 that the first stellar parallax was determined, and then, strangely enough, the problem was solved simultaneously for three separate stars by three different astronomers. Although the accuracy of these determinations was much inferior to that of modern determinations, they marked a great step forward in astronomy. The results obtained, together with the values derived from modern observations, are given in the table. The distances are given in terms of the mean distance of the Earth from the Sun as unit.

	Parallax.	Distance.	Modern Observations.	
			Parallax.	Distance.
<i>α</i> Centauri (Henderson) . . .	1.0	200,000	0.750	270,000
61 Cygni (Bessel)	0.314	640,000	0.285	700,000
<i>α</i> Lyrae (Struve)	0.262	760,000	0.100	2,000,000

Three different methods were used, which well illustrate the principles of parallax determination. Henderson deduced his parallax from observations of the zenith distance of *α* Centauri at different seasons of the year; this was the method which Bradley had used in his attempt to determine a stellar parallax which, though failing in its object, had led him to the discovery of the aberration of light. Struve used a clock-driven equatorial telescope and measured with a position micrometer the distance of *α* Lyrae from a faint star at an angular distance of about 40": the distance of the faint star was assumed to be much greater than that of *α* Lyrae, so that its parallactic displacement could be neglected in comparison and the relative parallactic displacement determined by the observations was attributed solely to the bright star. Bessel's method was analogous to that of Struve, but the distance apart of the two stars was determined with the aid of a heliometer (§ 105). Until the application of photographic methods, the heliometer provided the most accurate means of measuring small parallactic displacements. It suffered, however, from the disadvantages that the observations were slow and called for a high degree of skill in the observer if systematic errors were to be avoided. Great care is required in the adjustments and in the accurate determination of the scale value at different temperatures.

The only method now used for the direct determination of stellar parallaxes is the photographic one. It has the advantage of being not only more rapid, because economical of observing time, but it is also superior in accuracy even to the best heliometer determinations. The principle of the method adopted is to obtain a photograph of the star whose parallax is desired and then a second photograph about six months

later, when the parallax displacement is in the opposite direction. The position of the star is compared with the positions of several fainter stars in its neighbourhood by measuring the plate in an accurate micrometer. The variation in the relative distances between the two exposures will be due partly to the relative parallactic displacement and partly to the relative proper motions of the stars. By taking a further plate, at another interval of six months, when the parallactic displacement will have its former value but the proper-motion displacement will have doubled, it is possible to disentangle the two effects and so determine the parallax. Several refinements are necessary in order to secure a high degree of accuracy. Three or four plates should be obtained at each of three six-monthly epochs. The comparison stars must be as symmetrically placed as possible about the central star. The magnitude of the central star must be reduced by some means to that of the comparison stars, as, for example, by exposing it behind a rotating shutter with a sector of suitable size cut out—the object being to avoid spurious displacements due to slight errors in the motion of the telescope, these displacements varying with the magnitude of the image. The photographs should also be taken on or very close to the meridian.

When due care is taken the probable error of a determination by photographic methods should not exceed $0''.01$. The parallax derived in this way is relative to that of the faint comparison stars; the correction required to reduce it to an absolute value depends upon their magnitude, but can be determined from statistical considerations. It averages in general only about $0''.004$ or $0''.005$. The number of parallaxes determined with this accuracy is now somewhere about two thousand.

Particulars of the stars with largest known parallaxes are given in the following table:—

Name.	Annual Proper Motion.	Parallax.	Distance in Light-Years.	Luminosity. Sun = 1.	Spectral Type.
Proxima Centauri . . .	3.85	0.79	4.1	0.0001	—
α' Centauri	3.68	0.76	4.3	1.3	G0
Munich 15,040	10.29	0.53	6.2	0.0005	Mb
Lalande 21,185	4.74	0.41	7.9	0.0054	Mb
Sirius	1.32	0.38	8.6	30	A0
Cordoba, V h. 243 . . .	8.75	0.32	10.2	0.0022	K2
τ Ceti	1.92	0.32	10.2	0.35	K0
ϵ Eridani	0.97	0.31	10.5	0.31	K0
Procyon	1.24	0.30	10.9	7.0	F5
61 Cygni	5.24	0.30	10.9	0.064	K5

It will be noticed that all the stars in this table have large proper motions, illustrating the fact that large proper motion may be taken as a criterion of nearness. The values of the luminosities show that the stars in question are all dwarfs (§ 199). It will also be noticed that they are mainly of late spectral types.

194. Absolute Magnitude of a Star.—If the apparent magnitude of a star be known and also its parallax, it is possible to deduce the magnitude which the star would have when moved to a standard distance. This magnitude is termed an *absolute magnitude*, because it gives a relative measure of the intrinsic as contrasted with the apparent magnitude of the star. The standard distance most commonly used is 10 parsecs, corresponding to a parallax of $0''.1$. The absolute magnitude, M , is then expressed in terms of the apparent magnitude, m , and parallax ω (expressed in seconds of arc) by the relationship

$$M = m + 5 + 5 \log \omega.$$

For in bringing a star from a parallax ω'' to one of $0''.1$ its distance is increased in the ratio $10 \omega : 1$, and its apparent brightness is therefore decreased in the ratio $1 : (10 \omega)^2$, and the consequent increase in magnitude ($M - m$) equals

$2.5 \log (10 \omega)^2$, leading to the above formula. If the standard distance adopted is that corresponding to a parallax of $1''$, the relationship becomes $M = m + 5 \log \omega$.

Although the latter is not the method generally adopted for measuring absolute magnitude, it is of interest from the following fact: the apparent magnitude of the Sun, according to the most reliable determinations, is $-26\text{m}.72$. The parallax of the Sun to be used in the above formula being 1 radian or $206,265''$, it follows that the absolute magnitude of the Sun is $-0\text{m}.15$. Thus, if the standard distance is taken as 1 parsec, the absolute magnitude of the Sun, within the limits of observational error, is zero, so that a star with an absolute magnitude M has a luminosity L , which, expressed in terms of that of the Sun as a unit, is given by $\log_{10} L = -0.4M$ or $L = 10^{-0.4M}$. If $M = -5$, the star has a luminosity 100 times that of the Sun. If the unit of distance is taken as 10 parsecs, the corresponding formula will be $L = 10^{-0.4(M-5)} = 100 \times 10^{-0.4M}$, and a star of zero magnitude has a luminosity about 100 times that of the Sun.

195. Determination of Absolute Magnitudes.—The absolute magnitude of a star can be determined if its apparent magnitude and its parallax are known. The uncertainty attaching to the determination of both these quantities therefore enters into the value of the absolute magnitude.

Recently a method has been developed for determining absolute magnitudes which does not involve directly a prior knowledge of the parallax. The method is based upon the discovery that amongst the stars of a given spectral type there are slight differences in their spectra which depend upon their absolute magnitudes. It is known that spectral type is no criterion as to the physical nature of a star, for stars of the same type may and do show a very great range in density. It is at first surprising, therefore, that their spectra are so similar: we have seen, however, in § 192 that this is because the temperatures of their atmospheres are the same. Careful investigation has nevertheless revealed distinct differences in the intensities of certain definite lines, and an investigation of these differences for stars whose parallaxes, and therefore whose absolute magnitudes, are known, shows that the absolute

magnitudes and the spectral intensities can be directly correlated. By using all available material, the correlation has been placed upon a firm basis. A determination of the relative intensities of the crucial lines in the spectrum of a star therefore enables its absolute magnitude to be deduced with an accuracy much greater than that possible by calculation from its parallax, unless the parallax is relatively large.

Having determined in this way the absolute magnitude, the parallax of the star can be deduced if its apparent magnitude is known. Parallaxes so determined are termed *spectroscopic parallaxes* to distinguish them from the directly determined or *trigonometric parallaxes*.

196. The Angular Diameters of Stars.—Owing to the great distances of the stars their angular diameters are in all instances very small, probably in no case exceeding $0''.05$. The direct determination of their angular diameters is, therefore, a difficult matter, for even in the most powerful telescope no star shows a perceptible diameter.

The determination of a few angular diameters has recently been accomplished at the Mount Wilson Observatory by means of a method suggested first by Fizeau in 1868, but developed by Michelson. If two narrow parallel slits are placed over the object glass of a telescope (or anywhere in the converging beam of light) and the telescope is set upon a star, the light reaching the focal plane of the instrument will consist of two pencils which have passed through the two slits, and these pencils will be in a condition to produce interference. In the focal plane of the eyepiece a series of interference fringes, parallel to the direction of the slits, will in general be seen. For a certain distance apart of the slits these interference fringes will disappear, and mathematical investigation shows that this distance (d) is connected with the angular diameter (α) of the object by the relationship $d = 1.22 \lambda / \alpha$,* where λ is the mean wave-length of the light

* In deriving this formula it is assumed that the star-disk is of uniform brightness. If the brightness falls off towards the limb, as in the case of the Sun, the numerical constant in the formula requires to be increased. For the law of falling off obtained for the Sun, the constant would be 1.33.

from the star. If the slits are placed in the converging cone of light their distance apart as projected conically on the object glass of the instrument must be used. If d is expressed in inches and α in seconds of arc, this relationship becomes approximately $\alpha = 5''/d$. By this method, an angular diameter of $0''.05$ might just be measured with a telescope of 100 inches aperture, and this is the aperture of the largest existing telescope.

In order to measure still smaller diameters it is necessary

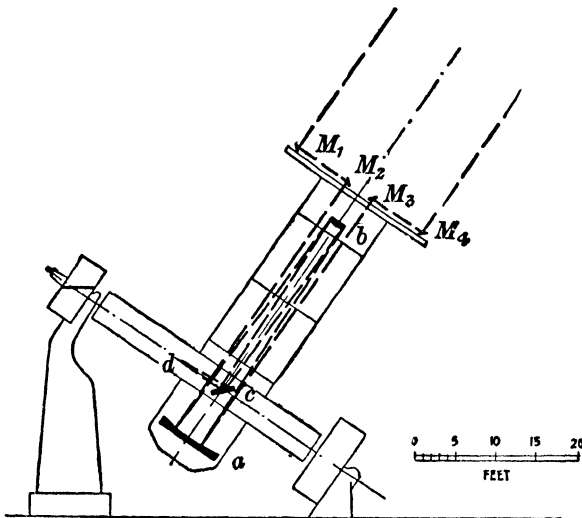

FIG. 94.—Stellar Interferometer as used with the Mount Wilson 100-inch Reflector.

to increase the aperture of the telescope. This is effectively done, in the case of the Mount Wilson 100-inch reflector, by placing a steel girder, 20 feet in length, across the upper end of the telescope tube. Attached to this girder are two plane mirrors, M_1 , M_4 , at equal distances from the axis of the telescope and inclined at an angle of 45° , so that the light from a star is reflected by them along the girder to two other plane mirrors, M_2 , M_3 , near its centre, 4 feet apart, which in turn reflect the light down the tube of the telescope, as shown in Fig. 94. The two beams, after reflection from the parabolic mirror a , the convex mirror b , and the flat mirror c , unite at

d and produce interference bands. The distance apart of the outer mirrors determines the separation of the two interfering beams. To vary the distance, these mirrors can be moved along the girder, remaining always at equal distances from the axis. The fringes were found to vanish in the case of Betelgeuse when the separation of the mirrors was 10 feet, corresponding to an angular diameter of $0''.046$, and in the case of Arcturus, when their separation was 19 feet, corresponding to an angular diameter of $0''.024$. Antares was found to have an angular diameter of $0''.040$.

The angular diameters can be calculated approximately from theory. The apparent surface brightness corresponding to each spectral type is known with fair accuracy from the determination of energy distribution in stellar spectra, by means of which estimates of effective temperature and surface brightness can be made, on the assumption that the stars radiate as black bodies. If the total apparent brightness is divided by this surface brightness the result is the angular area subtended by the star. Since the surface brightness is independent of the distance, the value obtained is not dependent upon a knowledge of the distance of the star. Thus, if the surface brightness J is estimated in terms of that of the Sun as unit and if D denotes the apparent angular diameter of the star, m its visual magnitude, then, since the mean angular diameter of the Sun is $32'$, and the Sun's apparent magnitude is -26.7 , we have

$$\begin{aligned} \text{Light from Sun : light from star} &= (2.512)^{m+26.7} \\ \text{or } \left(\frac{1920}{D}\right)^2 \frac{1}{J} &= 2.512^{m+26.7} \\ D &= 1920 J^{-\frac{1}{2}}(2.512)^{-13.35-\frac{m}{2}} \\ &= 0''.0088(0.631)^m J^{-\frac{1}{2}} \text{ approximately.} \end{aligned}$$

Hence D can be determined when m and J are known. The angular diameter so determined for Betelgeuse is $''051$ and for Arcturus is $''020$, in close agreement with the observed values. This agreement lends support to the following table, given by Eddington, showing the probable angular diameters for giant stars of various types and visual magnitudes.

Type. Vis. Mag.	A	F	G	K	M
m.	"	"	"	"	"
0.0	·0034	·0054	·0098	·0219	·0859
2.0	·0014	·0022	·0039	·0087	·0342
4.0	·0005	·0009	·0016	·0035	·0136

197. **Phenomena associated with Spectral Type of Stars.**—(i) *Velocities.* For the complete specification of the velocity and direction of motion in space of a star, it is necessary to know its radial velocity, proper motion, and distance. As the distances of relatively few stars are known with sufficient accuracy, the relationship between velocity and type can best be discussed through the radial velocities, because these are not dependent upon the distances and because the effect of the solar motion can easily be eliminated. For a single star, the radial velocity may be small although the actual velocity of the star is very large, but if the mean of a group is taken, the mean radial velocity (corrected for solar motion) will be proportional to the mean total velocity and so will furnish a criterion of relative speeds.

When this is done, it is found that the average velocity increases continually as we pass through the series of spectra from the earliest to the latest types. This was first shown conclusively by Campbell, from the extensive radial-velocity determinations made at the Lick Observatory. His figures are as follows:—

Type of Spectrum.	Radial Velocity, km. per sec.	No. of Stars.
B	6.52	225
A	10.95	177
F	14.37	185
G	14.97	128
K	16.8	382
M	17.1	73

The velocities given in this table are not corrected for the star

stream motions, but when the effect of these systematic motions is allowed for, the progression in velocity is still shown.

The proper motions of the stars can be used to confirm the reality of this phenomenon. If the proper-motion of each star is resolved into two components, one towards the solar antapex and the other at right angles to it, the mean parallax of a group of stars of any type can be determined from the mean motion towards the antapex, as explained in § 187. Using this mean parallax, the component of proper motion at right angles to the direction to the antapex (the *cross* motion) can be converted into linear measure. These velocities should be comparable with the radial velocities. In this way, Boss determined the following values :—

Type.	Cross Linear Motion. km. per sec.	No. of Stars.
B	6.3	490
A	10.2	1,647
F	16.2	656
G	18.6	444
K	15.1	1,227
M	17.1	222

These values, though naturally somewhat more uncertain than those derived from the radial velocities, are in sufficient agreement with them to confirm the gradual progression in velocity.

198. (ii) *Distances*. The mean distance of a group of stars of given spectral type depends upon the mean magnitude of the group, for, on the average, the fainter a star the more distant it will be. In comparing the relative distances of stars of different spectral types, it is necessary, therefore, to take groups of stars of the same apparent brightness. Then, as has just been explained, the mean parallax of the group can be calculated from the mean component of the proper motion in the direction of the solar antapex. Such investigations have been made by Boss, Campbell, Jones, and others ; in all cases the mean parallax is found to increase from type

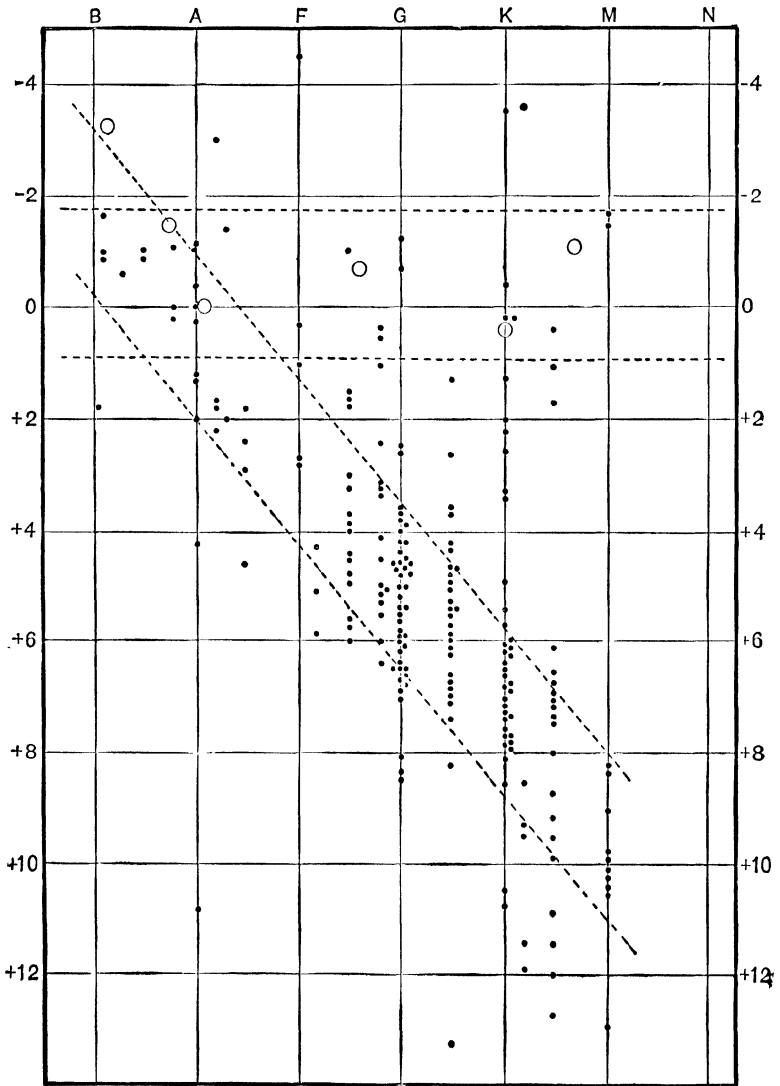

FIG. 95.—Giant and Dwarf Stars (Russell).

B to type F and then to decrease gradually to type M, whose mean parallax is somewhat greater than that of the early B-type stars. On the average, therefore, the stars of type F are the nearest to the Sun, those of type B the most remote.

These results are of importance in connection with the general question of stellar evolution.

199. (iii) *Luminosities.* When the absolute magnitudes of stars are arranged according to their spectral type a remarkable relationship is found. If the unit of distance to which the absolute magnitudes are referred is 10 parsecs, it is found that for stars of type B, practically all the stars fall within a magnitude range of -3 m. to $+1$ m. (1,600 to 40 times the luminosity of the Sun). For succeeding types, the range of magnitude gradually increases, the maximum brightness remaining about the same, but the minimum brightness decreasing. In the case of type M, the range is from about -2 m. to $+12$ m., but the stars are clustered in the neighbourhood of the two limits, there being few if any stars of this type with absolute magnitudes between $+2$ m. and $+6$ m. This separation into two classes can be seen, though less distinctly, in type K. It was pointed out by Russell that if absolute magnitudes as ordinates are plotted against spectral types as abscissæ, the general configuration of the plotted points is along two lines, as shown in Fig. 95. There thus appear to be two series of stars: the members of one of these are very bright with an average luminosity several hundred times that of the Sun, and independent of the type of spectrum, whilst the luminosities of the members of the other series diminish rapidly in brightness with advancing type. These two series of stars were called by Russell "giant" and "dwarf" stars respectively.

Other lines of argument have confirmed the reality of the distribution of stars into these two classes, and the separation is now of fundamental importance in astronomy.

200. **The Velocities of Stars and their Brightness.**—Recent work has shown that in addition to the gradual progression with spectral type of the average velocities of the stars there is also a progressive increase of velocity with

diminishing absolute brightness. This result has been indicated from discussions of both radial velocities and proper motions, and is not connected with the separation into giants and dwarfs, since it is found to hold for the giant stars of a given type.

The relationship may be illustrated by the stars in the immediate neighbourhood of the Sun. It is probable that most of the stars within a radius of 5 parsecs are known, and the distances of these stars have been measured. That the stars of least luminosity have the greatest velocity is shown by the following results:—

	Luminosity (Sun = 1).	Mean Cross Velocity (km. per sec.).
9 brightest stars	48.0 to 0.25	29
10 faintest stars	0.10 to 0.004	68

The radial motions of these faint stars have also been found to be more than twice that of the brighter stars of their type.

It has been suggested that the progressions of speed with type and with velocity may be in reality a mass phenomenon. If the stellar universe is in a steady state, the average kinetic energy of each star would be the same, as in the case of the molecules of a gas in thermal equilibrium. The stars of largest mass would therefore have the smallest velocity, and *vice versa*. It is known that the average mass of the B-type stars is several times that of the stars as a whole, and from this view-point their small velocity is to be expected. To account for the progression with luminosity, it is only necessary to assume that the stars of small mass do not attain to as great a luminosity as those of large mass.

Although it is not probable that the Universe is in what is termed, in the kinetic theory of gases, a steady state of statistical equilibrium, it is probable that it is sufficiently near to such a state for the law of equipartition of energy—according to which the average kinetic energy of translation of each star should be the same—to hold approximately. The progression of speed with type and with mass then follow as a rational consequence.

CHAPTER XIII

DOUBLE AND VARIABLE STARS

201. **Double Stars.**—Many stars which to the naked eye appear single are found when examined in a telescope to be double; as well-known instances of double stars may be mentioned Castor and 61 Cygni. The existence of such stars has been known since the seventeenth century, but the first systematic search for doubles was carried out by Sir William Herschel commencing in 1779. To-day many thousands of such stars are known. In fact, down to about the ninth magnitude, about one star in eighteen is found to be a double.

Stars may appear double from two causes: (i) the two stars may be at very different distances but nearly on the same line of sight, in which case there is no physical connection between them: such pairs of stars are termed optical doubles. (ii) They may be at the same distance and physically connected, revolving about their common centre of gravity under the action of their mutual attraction. Such pairs are termed binary systems and are the ones of interest to the astronomer.

Herschel had supposed that the double stars discovered by him were only optically double, and his object in observing them was to use the relative parallactic displacements of the two components to determine the solar motion. It was shown by Michell, in 1784, from considerations of probability, that some at least of Herschel's pairs must be physically connected. If the stars visible to a good eye were distributed over the celestial sphere at random, the probability against two or three pairs being so nearly in the same direction that they would appear single to the naked eye would be very great, and the chance that any of these would be as close as some of Herschel's closer pairs would be so small as to be negligible.

In any particular instance, only by observations extending over a period of time is it possible definitely to decide whether a double star is a binary system or merely an optical double, although, in many cases, the physical connection of the two components can be regarded as probable. The nearer the two stars and the brighter they are, the greater is the probability that they constitute a binary system. Of the 20,000 or so double stars which have been catalogued, it is not possible at present to state how many are binary systems, but in general it may be assumed that if the pair is wide and shows appreciable relative motion it is probably optical, whilst if the relative motion is much smaller than the proper motion of the pair, or if the stars are less than 5" apart and as bright as the ninth magnitude, they are probably physically connected.

In the case of stars which are physically connected, the period over which observations must be extended in order that the relative orbital motion may be detected will be greater the larger the angular separation of the two components. If the separation is greater than 2", relative motion will probably not be detected with certainty in a century.

202. Measurements of Double Stars.—The two quantities which it is necessary to measure in connection with a double star are the angular separation of the components and the position angle, which determines the direction of the great circle on the celestial sphere passing through the two stars. Both these quantities can be determined with the filar micrometer. For accurate observations, good atmospheric seeing and acuity of vision are essential. Since the resolving power of a telescope of " d " inches aperture is approximately $5/d$ seconds of arc, it follows that for the measurement of pairs with separations of 1", 0".5, 0".2, telescopes of apertures of at least 5, 10, and 25 inches respectively are required.

The interference method used for the determination of the angular diameters of stars (§ 196) can be applied with advantage to the observation of close double stars. If the stars are of the same brightness, the interference fringes produced in the focal plane by the double slit disappear for an appropriate separation, l , of the slits provided that the line joining the stars is at right angles to the slits. The distance apart of the

slits for which the fringes disappear is connected with the angular separation, a , by the relationship $a = \frac{1}{2}\lambda/l$, λ being the mean wave-length of the light. The method consists, therefore, in determining the orientation and separation of the slits for which the fringes disappear. The former quantity determines the position angle of the pair, the latter the angular separation. If the two stars are not equal in brightness, the fringes do not completely disappear for any orientation of the slits; there are then positions of maximum and of minimum visibility, and it is the latter which must be observed. This method possesses the advantages that it is practically independent of the quality of the atmospheric definition at the time of observation, and that it is greatly superior in accuracy to the filar micrometer method. It will also be noticed that for a telescope of aperture d , the smallest angular separation which can be measured is $\frac{1}{2}\lambda/d$, whereas by ordinary methods the least angle measurable (corresponding to the limit of resolution of the telescope) is $1.22\lambda/d$. The resolving power is in effect increased by this method of observation in the ratio of about 2.44 to 1. With a 25-inch telescope, stars with separation down to $0''.08$ are measurable as compared with a limit of $0''.2$ with the filar micrometer.

203. Orbits of Binary Stars.—According to the law of gravitation, each component of a binary system must describe an elliptical orbit about the common centre of gravity as one focus. The two ellipses, and also the elliptical orbit of the one star relative to the other, are precisely similar, differing only in linear dimensions. The orbit described by the smaller star is larger than that described by the other in the inverse ratio of their masses. The major axis of the relative orbit is equal to the sum of the major axes of the two real orbits.

In general, the plane of the relative orbit is inclined to the line of sight so that observation gives only the projection of the orbit upon the celestial sphere. The projected relative orbit in such a case will still be an ellipse, but the larger star will no longer be at its focus; the projections of the major and minor axes of the real orbit will not be at right angles and will not be the major and minor axes of the projected orbit. Since, however, equal areas project as equal areas,

the smaller star will still describe equal areas about the larger star in equal times in the projected orbit.

Using the knowledge that the larger star is in the focus of the real relative orbit, it is possible to determine theoretically the shape of the orbit, its angular dimensions, and its inclination to the line of sight as well as the period in which the orbit is described. Three observations, if free from error, would suffice to determine the orbit. In practice, a greater number must be used in order to eliminate observational errors. Generally speaking, the position angles in the case of close pairs are more valuable than the separation, and the values of the angles at various epochs suffice to determine the shape of the orbit.

The orbits of about eighty double stars are known with a fair degree of accuracy.

204. Masses of Double Stars.—If m_1 , m_2 are the masses of the two components of a double star in terms of the Sun's mass, P the period in years, a the semi-axis major in seconds of arc, ω the parallax in seconds of arc, then Kepler's laws give

$$(m_1 + m_2)P^2\omega^3 = a^3.$$

If, therefore, the parallax of a double star whose orbit has been computed can be determined, it is possible to deduce the mass of the system. It is only for a small number of systems that all the required data are known. For fourteen such systems, the masses are found to vary from 0.45 to 3.3 times the mass of the Sun, with an average of 1.8. This result is in accordance with other lines of evidence which indicate that the range in mass of the stars is not very great.

If, then, it be assumed that the total mass of the system is twice that of the Sun, the above relationship becomes $2P^2\omega^3 = a^3$, and the parallax can be deduced when the elements of the orbit are known. It should be noted that in determining ω , the mass enters as a cube root, so that if the mass of the system were sixteen times instead of twice that of the Sun, the value deduced from the formula $2P^2\omega^3 = a^3$ would be only double the actual value. This method is very useful for determining theoretical or "hypothetical" parallaxes of double-star systems.

On the assumption that the combined mass of the system is double that of the Sun, the following table has been compiled giving the approximate periods of binary stars for different angular semi-axes majores and parallaxes :—

Angular Separation.	Revolution Period for Parallax.			
	0".1.	0".05.	0".01.	0".005.
"				
0.25	2½ years	8 years	90 years	250 years
0.50	8 "	20 "	250 "	700 "
1.00	25 "	65 "	700 "	2,000 "
2.00	65 "	180 "	2,000 "	5,600 "
5.00	250 "	700 "	7,900 "	22,000 "

The method just explained for determining the hypothetical parallax of a double-star system whose orbit is known can be extended to the case of any double star which shows appreciable relative angular motion, but which has not completed an arc sufficiently large to enable the orbit to be computed.

If ω is the parallax, d the mean separation, and w the mean angular motion in degrees per year, then

$$\omega = k \cdot dw^2/3$$

where k is a constant whose value depends upon the precise assumptions made, but which may be taken as 0.022 without serious error.

Thus, in the case of the star No. 4,972 in Burnham's General Catalogue, the position angles and separations at two epochs are—

1830	47.5	20.4
1914	68.5	18.9

The angular motion is 21° in 84 years, so that $w = \frac{1}{4}$. Also $d = 19.65''$. Hence $\omega = k \times 19.65^3 \sqrt{16}$ and the hypothetical parallax is 0".17. The trigonometrically determined value is 0".15. In this way, reliable parallaxes of many double stars may be determined.

205. **Spectroscopic Binaries.**—Some double stars are so close that it is not possible to separate them visually with

any existing telescope. The duplicity of many such stars can be detected with the spectroscope. Suppose the two components are of the same spectral type and that the orbital plane is edgewise to the observer. Then, when the line joining the stars is perpendicular to the line of sight, one of the stars will be moving towards and the other away from the observer. The lines of the spectra of the two component stars will be displaced, according to Doppler's principle, in opposite directions, and the lines of the resultant spectrum which is obtained by superposing the two component spectra will therefore appear double. On the other hand, when the two components are in the line of sight, the lines will appear single.

If the two components of the star are not of the same spectral type, the spectrum will be more complex, but the displacements of the two sets of lines can still be detected. Double stars whose components are so close that they cannot be separated visually, but whose duplicity can be detected spectroscopically, are termed spectroscopic binaries.

The first spectroscopic binary to be discovered was the brighter component of the double star Mizar in the Great Bear. Pickering in 1889 found that the dark lines in its spectrum appeared double at regular intervals corresponding to a period of $20\frac{1}{2}$ days.

The number of spectroscopic binaries which have been discovered amounts to many hundreds and is rapidly increasing. They have been found principally amongst the brighter stars because these are the stars whose spectra are most easily obtained. Those of faint stars, on a scale suitable for radial-velocity determination, require large instruments and long exposures. Of the stars examined, Campbell states that at least one in five is found to be a spectroscopic binary, and there is no reason why this should not hold for the fainter as well as for the brighter stars. For some spectral types, the proportion seems to be even greater; thus, for class-B stars, about two stars in five are spectroscopic binaries.

206. Orbits of Spectroscopic Binaries.—If a photograph of the spectrum of a spectroscopic binary is obtained on a sufficiently open scale along with a suitable comparison spectrum, the displacements of the lines can be measured

directly and the velocity in the line of sight of one or, in some cases, of both components determined.

Theoretically, five such observations at different points of the orbit would suffice to determine the orbital elements, but practically the number of observations must be considerably increased to allow of the elimination of the accidental errors of observation. It may then happen that the observations have extended over more than one revolution of the components, since the periods of spectroscopic binaries are much shorter than those of visual doubles. The observations enable a provisional value of the period to be determined, by means of which they may all be reduced to a single revolution. A curve can then be drawn to represent the velocity at any epoch during the revolution.

Since the radial velocity is a maximum or minimum at the two nodes of the orbit, i.e. at the points of intersection of the orbit with a plane perpendicular to the line of sight, the positions on the velocity curve of these points can be assigned. By a simple mathematical procedure it is further possible to deduce the positions of apastron and periastron, relative to the node of the eccentricity, and of the quantity $a \sin i$; a is the semi-axis major of the orbit expressed in kilometres and i is the angle between the line of sight and the normal to the orbital plane. Neither a nor i can be separately determined from the observations of radial velocity. Observations of visual doubles, on the other hand, determine both a and i , a being found, however, in angular and not in linear measure and the sign of i remaining undetermined, i.e. the observations cannot distinguish between the two planes, which make an angle i with the plane perpendicular to the line of sight. The longitude of the node cannot be determined for spectroscopic binaries.

It is possible in the case of a few systems to obtain both visual and spectroscopic observations. In such cases the sign of i can be determined and also the actual linear value of a . Since a is then known in both angular and linear measure, the parallax of the system can be deduced. If, in addition, the velocity of both components can be observed spectrographically the ratio of their masses can be determined, the masses being inversely proportional to the amplitudes of the two velocity curves. From visual observations, the total mass can be

determined when the parallax is known and the values of the separate masses can therefore be obtained. A complete knowledge of such systems can therefore be obtained.

In this way W. H. Wright determined the parallax of α Centauri, which has been observed both visually and spectroscopically as a double, and obtained a value $0''.76$ in exact agreement with the heliometer determination by Gill. The masses of the two components are each nearly the same as that of the Sun. The components are separated at periastron by eleven astronomical units and at apastron by thirty-five units.

207. Triple and Multiple Stars.—Many stars which were at first thought to be double are now known to be more complex in nature, and the number of triple and multiple systems is steadily growing. In some cases the additional components can be detected spectroscopically; in others their existence is inferred indirectly. A good example of a multiple system is the well-known visual double, Castor. Each component is now known to be a spectroscopic binary; the period of one is nearly three days and of the other rather more than nine days. The period of the one binary about the other is somewhat uncertain, but is of the order of 300 years.

The North Star, Polaris, provides an interesting example of a triple system. It was first found to have a variable radial velocity and then proved to be a spectroscopic binary with a period of nearly four days. The velocity of the centre of mass of the visible system is, however, subject to a slow variation, indicating that the binary is attracted by and is moving around a third star which is invisible to us. The orbit is eccentric and the period of this motion exceeds twenty years.

Sometimes it is the smaller or fainter star of a pair which is a close binary. As an example may be mentioned the star 40 Eridani. This star consists of a bright component of magnitude 4.5 with a faint component of magnitude 9.2, separated from it by a distance of $82''$. The faint component is itself a visual double with a period of 180 years and the smallest eccentricity of any known visual double. Both bright and faint stars have a large proper motion, which indicates a physical connection between them, but they show very little relative motion, as might be anticipated from the wide

separation. The period of revolution of the binary about the primary is of the order of 7,000 years. The orbit of the faint components is nearly as large as Neptune's, whilst that of the faint about the bright star is about 470 astronomical units. The system is therefore somewhat similar to but on a much greater scale than the Earth-Moon-Sun system.

Many other instances of such complex systems are known. They are of interest from the information which they enable us to obtain as to masses, luminosities, etc., of various stars; information which is of value on account of its bearing upon the general question of stellar evolution.

208. Variable Stars.—Another class of stars of great interest and importance are the stars whose light is variable. The number of known variable stars is several thousands and is being added to continually. Many of these stars vary in a very irregular manner; others, on the other hand, exhibit a remarkable constancy in the period of their variation, so that the maxima and minima of brightness can be predicted with certainty beforehand. The periods of the light variations range from a few hours to several hundred days; on the average the greatest variations in brightness occur with the long-period variables.

There are so many different types of variation and so many different features present themselves from one star to another that it is necessary, in order to obtain a broad view of the problems presented by variable stars, to divide them into several main classes. Various systems of classification have been adopted, but that suggested by Pickering is perhaps the simplest for our present purpose. He divided variable stars into the following classes:—I, Novæ or temporary stars; II, long-period variables; III, variables of small range or irregular variation; IV, short-period variables; V, eclipsing variables.

The characteristics of these several classes will be considered briefly in the following sections.

209. Novæ or New Stars.—A star to which the name of nova or new star is applied is one which experiences one sudden and usually considerable increase in brightness, after which its light diminishes at first somewhat rapidly, and then

more slowly, to a more or less steady value. No instance is known of the same star experiencing two such outbursts. The characteristic features of the light changes of a nova are the rapid and large increase of the brightness to a maximum, and the more gradual falling away, accompanied by numerous small and irregular oscillations. These features may be illustrated by the two most recent novæ, Nova Aquilæ III, 1918, and Nova Cygni III, 1920.

Nova Aquilæ III before its outburst was a faint star of magnitude between 10 and 11, which showed irregular variations in light with an amplitude of about one magnitude. It is not known whether this is a characteristic feature of the early history of novæ, for, in general, such history can only be investigated after the outburst has taken place by finding earlier photographs on which the nova is shown. A photograph of the region around Nova Aquilæ was obtained at Heidelberg on 1918, June 5, and the star was then of magnitude 10.5. On a photograph obtained at Harvard on June 7, it appears of the sixth magnitude. On the following evening, when it was discovered by several observers independently, it reached almost the first magnitude. The next evening (June 9), it was with the exception of Sirius and Canopus the brightest star in the sky (-0.5 m.). Its increase in brightness in a period not exceeding four days was therefore about 2500 : 1. The light then commenced to decrease; by June 17, its magnitude had fallen to about 2; by June 22, to 3. At the end of June, the irregular oscillations in brightness commenced, these being superposed upon a progressive fall in mean brightness. By the end of the year the brightness had decreased to about 6 m. It is now fainter than 10 m.

Nova Cygni III was discovered by Denning on 1920, August 20, its magnitude being then about 3.5 m. Little is known of its history before the outburst, but the star does not appear on earlier photographs reaching to the fifteenth magnitude, and it must therefore have been extremely faint. Photographs of the region around it were obtained at Harvard on August 9, and on August 20. On the earlier photograph, going down to 9.5 m., the star does not appear. On the later, taken the night before its discovery, it was of magnitude 4.8 m. It was photographed in Sweden on August 16, and was then of

magnitude 7.0 m. On August 22, it had attained a magnitude of 2.8 m., and on August 24 it reached a maximum of about 2 m. Thus, although its maximum brightness was inferior to that of Nova Aquilæ, the increase in brightness was consider-

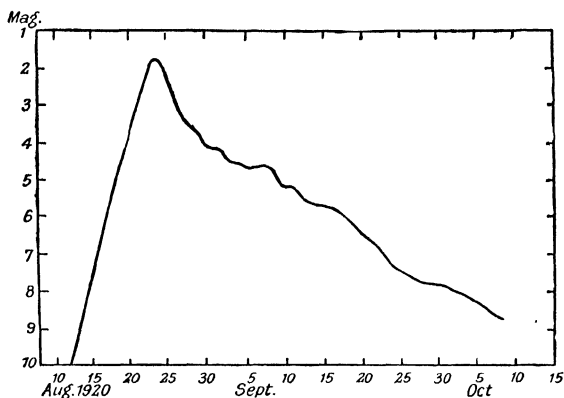

FIG. 96.—The Light Curve of Nova Cygni (1920).

ably greater. The decrease in brightness was much more rapid. By the end of August, the magnitude had fallen to 4 m. and oscillations had started, and by the end of October it was fainter than 9 m. The light curve is shown in Fig. 96.

Whether the final magnitude of a nova after its outburst becomes in general equal to its mean magnitude beforehand is uncertain, though it is known that in some cases this is not so. Thus, Nova Coronæ, 1866, before its outburst was of magnitude 9.5 m. and is now of magnitude about 11.5 m.

Although these two examples illustrate the usual course of light changes in novæ, there are exceptions. Thus, the star P Cygni, when discovered by Janson in 1600, was of the third magnitude. In 1602 the star was observed by Kepler and was still bright, but in 1621 it had become invisible to the naked eye. In 1655 it again attained the third magnitude, but vanished in 1660, and in 1665 was again visible, though fainter. Since 1677 its brightness has remained constant at about 5 m. Somewhat similar changes occurred in the case of the Nova II Vulpeculæ, discovered by Anselm in 1670.

The brightest novæ on record are Nova Cassiopeiæ, dis-

covered by Tycho Brahe in 1572, which reached -4 m., brighter even than Venus; and Nova Ophiuchi, discovered by Kepler in 1604, which reached -2 m. Both these stars are now very faint and cannot be identified. The next brightest novæ appeared in recent years, Nova Persei, 1901 (0.0 m.) and Nova Aquilæ, 1918 (-0.5 m.). The majority of the novæ which have been observed have been situated in or near the Milky Way.

210. Spectral Changes of New Stars.—The changes in brightness of a new star are accompanied by remarkable changes in the spectrum of an exceedingly complex nature, the explanation of which is not at present fully understood. The spectrum at an early stage of the outburst is characterized by absorption lines of hydrogen and calcium, which are strongly displaced towards the violet; this displacement is similar in nature to a Döppler displacement, but if interpreted in this manner, the velocities involved are very great and variable from day to day. In the case of Nova Aquilæ III, the displacements corresponded to velocities of about 4,500 km. per second. Most of these absorption lines are accompanied by faint broad emission lines which are displaced but little from their normal positions. The absorption lines gradually become more numerous and prominent and are due mainly to enhanced spark lines of titanium and iron. A few days later the absorption lines become double, the displacements of the two components corresponding in the case of Nova Aquilæ to velocities of about 1,400 and 2,100 km. per second; the continuous background of the spectrum at the same time becomes weaker and the bright bands broaden. The spectrum is at this stage very complex and is somewhat similar to a superposition of spectra of types B and A, displaced relatively to one another. The B-type spectrum gradually becomes more prominent and the A type less prominent, the latter finally disappearing. Nebular lines now begin to appear and the hydrogen lines to become less prominent, the spectrum being a bright band spectrum, due mainly to hydrogen, helium, and nebulium. The hydrogen lines continue to become fainter and the spectrum reaches a stage when it is practically nebular. At a later stage, the hydrogen and helium lines become stronger

again and the spectrum assumes the typical features of the spectra of Wolf-Rayet stars.

The details vary considerably from star to star and the changes are so rapid and complex that it is a difficult problem to elucidate their meaning. Nevertheless rapid progress has been made in the case of recent novæ which should in the future throw much light upon the physical causes responsible for the outburst.

211. Theories of New Stars.—Many theories have been put forward to account for the various phenomena presented by the novæ. Whilst none of these theories can at present be regarded as satisfactorily proven, the balance of probability is strongly against some of them, which we can therefore disregard here. There are really two problems requiring solution; the cause of the original outburst and the nature of the subsequent occurrences which are responsible for the complex changes evidenced by the spectra.

The doubling of many of the lines in the spectra of novæ naturally suggested the theory that two stars were concerned in the production of the outburst. The two stars were supposed on this theory either to have collided directly or to have approached so near to one another that enormous disturbances of a tidal nature were set up; such a theory could account for the suddenness of the outburst and its more gradual decay. It must be supposed that one of the stars has an absorption spectrum and the other a bright line spectrum; also that the former star is moving towards the Earth and the latter away. The frequent occurrence of novæ in the Milky Way would then be attributed to the greater density of stars there. On this theory we must suppose that in all the novæ which have been spectroscopically studied, one of the stars involved possessed a bright line spectrum, and was receding from the Earth with a small velocity, and that the other possessed an absorption spectrum and was moving towards the Earth with a large velocity. It is extremely improbable that chance encounters of stars could have produced results obeying such a clearly marked law. In addition, the density of stars in space is so small that it is improbable that collisions between two stars would occur as frequently as novæ are observed.

A more plausible theory attributes the outburst to the passage of a dark or feebly-luminous star through a mass of nebulous matter. The star is heated by frictional resistance to incandescence, on entering the nebula, and the composite absorption and bright line spectrum would be anticipated. The displaced absorption lines are on this theory due to expanding and cooling gases moving out from the centre of the disturbance, and the displacement would naturally correspond to a motion towards the observer. If successive streams of matter are emitted, the double, or in some cases the triple structure of the lines, could be accounted for. The alternations between bright bands and strong absorptions would be expected, the absorption appearing when the stream was pointed towards the observer. If the star were a binary system certain additional peculiarities of some novæ would be accounted for. This theory is to some extent directly confirmed by observation; both in the case of Nova Persei II and Nova Aquilæ III, the star was found some time after the outburst to be surrounded by a disc of nebulous matter of appreciable angular diameter. This may be the glowing envelope formed by the ejected matter. When this envelope becomes the chief seat of the radiation, the spectrum would change to a bright line spectrum. We have also seen that the final stage of a nova spectrum is similar to that of a Wolf-Rayet star. It is significant that these stars are usually found in association with nebulosity and that they occur (apart from the Magellanic Clouds) only in the Milky Way. Collisions between stars and nebulae would naturally be much more frequent than between two stars and would occur mainly in the Milky Way. It may, therefore, be not improbable that all the Wolf-Rayet stars known are merely novæ in their late stages. In the case of Nova Persei II, a nebula was certainly associated with the outburst, for bright nebulosity was seen to be moving out from it and was interpreted as the brightening of a dark nebula by light spreading out from the original outburst; the distance of the nova calculated on this assumption agreed with that directly determined by the ordinary methods.

212. Long-period Variables.—When variable stars are classified according to their period, it is found that there are

a large number with periods of less than 11 days and a large number with periods between 150 and 450 days, but that only a relatively small number have periods between 11 and 150 days. A fairly definite subdivision into two classes according to period is therefore possible with some overlapping for periods between, say, 50 and 150 days. Long-period variables are those with periods exceeding 150 days.

There are several well-pronounced characteristics of long-period variation. The range of variation is large, usually from three to eight magnitudes; the period and the magnitude at maximum are usually somewhat irregular; the stars are reddish in colour, and the redder the tint, the longer is the period.

The best known long-period variable is Mira or α Ceti, discovered by Fabricius in 1596. This star has a mean period of 333 days, which is subject to large variations. Its brightness varies from the second to the ninth magnitude. The magnitude at minimum varies from about 8.5 m. to 9.6 m., but the value at maximum is still more irregular, as the following table indicates :—

1868	5.2 mag.	1886	5.0 mag.
1869	3.9 „	1896	4.0 „
1875	2.5 „	1897	3.2 „
1879	4.2 „	1898	2.4 „
1885	2.8 „	1900	3.4 „

The rise to maximum brilliance is more rapid than the decline. The spectrum is of type Md, with bright hydrogen emission lines. The radial velocity observed near maximum does not vary, indicating that the star is not a spectroscopic binary, but the value given by the dark lines is 62 km. per second away from the observer, whereas that given by the hydrogen lines is only 48 km. per second. This suggests that the increase in brightness is due to outbursts of hydrogen gas occurring with approximate regularity.

The spectra of long-period variables are all of classes Ma, Mb, Mc, Md, or N $\frac{3}{4}$; no star with spectrum of type Md is known which is not a long-period variable.

The periodic outbursts occurring in the long-period variables have been compared with the outbursts of activity on the Sun,

evidenced by the Sun-spot cycle and allied phenomena. It has been suggested that the Sun should be regarded as a long-period variable, with a very long period and a small range in brightness; the rise to maximum spot activity in the case of the Sun is more rapid than the subsequent decline, so that in this respect the analogy holds. On the other hand, no long-period variable is known with so long a period, so small a range of brightness, and a spectrum of such early type. The comparison seems therefore to be somewhat misleading.

213. Special Long-period Variables.—There are a few long-period variables whose behaviour is somewhat different from that described in the preceding section. These were assigned by Pickering to sub-classes IIb and IIc. The first of these includes U Geminorum, SS Cygni, SS Aurigæ. As a typical

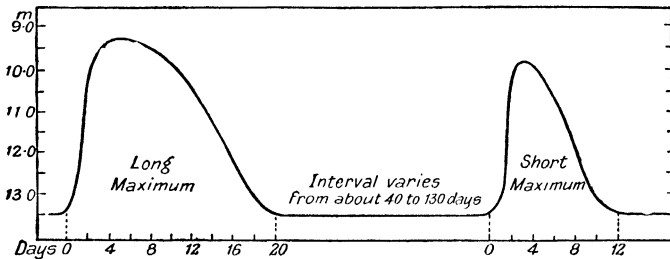

FIG. 97.—The Light Curve of U Geminorum.

example U Geminorum, discovered by Hind in 1855, may be considered (Fig. 97). The normal state of the star is one of constant (minimum) brightness, about 13 m.; from time to time its light increases very suddenly to a maximum of 9.5 m., which does not last for any regular interval of time and is then followed by a more gradual fall to its constant minimum value. Two distinct types of maximum are known and occur alternately; they are called the long and the short, the star remaining above minimum brightness for about twelve and twenty days respectively. Successive outbursts occur at irregular intervals which may vary from 60 to 152 days. In the case of SS Cygni, there is even a third type of maximum.

Owing to the faintness of these stars, little is known about their spectra or radial velocities and no plausible theory has been advanced to account for the phenomena.

The sub-class IIc includes the stars R Coronæ Borealis, RY Sagittarii and SU Tauri. R Coronæ Borealis is normally of about the sixth magnitude. At irregular intervals, which may be months or years, its light decreases, passes through a minimum value, and finally attains again its normal brightness. The variation may range from as much as 9 m. to as small as 1 m., and its duration from a few years to several months. The decrease in brightness is usually more rapid than the subsequent increase. These changes suggest that the light from the star is from time to time obscured by an absorbing medium passing between the star and the observer, which may have some physical connection with the star.

214. Irregular Variables.—Class III in the classification is a large one comprising stars whose variation is so irregular that no period can be assigned to them. The variation in brightness of stars of this class is usually small, averaging less than 2 m. It comprises stars of all spectral types from G to N, including many stars having peculiar spectra. The cause of the variation is not at present known, though it is not impossible that in these red stars there may be a crust forming over the surface. As the crust forms the light diminishes. But a certain stage is reached at which the pressure of the imprisoned gases becomes so great that they break through the crust with more or less violence, and with corresponding increase in brightness. Such occurrences would naturally take place at somewhat irregular intervals, but, averaged over a sufficiently long period, the mean interval may be expected to remain fairly constant.

215. Short-period Variables.—*Cepheid Variables.* The stars of Classes IV and V are all short-period variables and are characterized by a small range of variation and a perfectly regular period. These variables can be divided into two main groups — stars which are known to be binary systems and to be variable on account of one component periodically eclipsing the other (Class V), and stars whose variation cannot definitely be attributed to eclipses (Class IV). The latter will be considered first.

The short-period variables belonging to Class IV are generally

called Cepheid variables from the typical star δ Cephei (Fig. 98). The range of variation is small, generally less than 1 m., and the periods range from less than one day to one or two months. δ Cephei has a range of about 0.7 m. and a period of nearly five

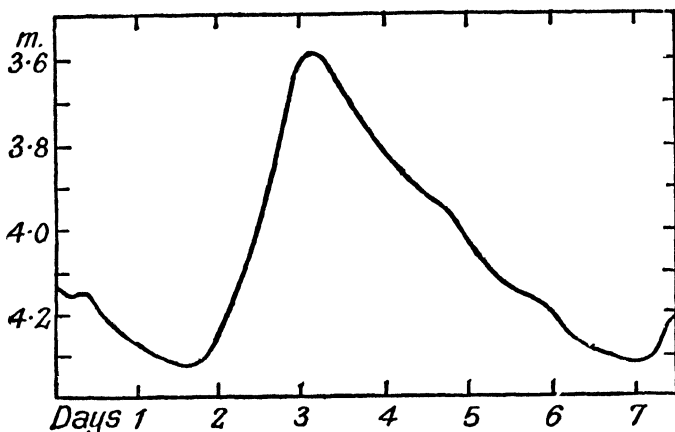

FIG. 98.—The Light Curve of δ Cephei.

and a half days. The rise from minimum to maximum occurs in about one and a half days, and is, therefore, much more rapid than the decline to minimum which occupies the remaining four days of the period. The decline is not uniform, but is accompanied by secondary oscillations. Some stars belonging to this group, such as ζ Geminorum, have a practically symmetrical light curve.

The Cepheid variables have spectra of all types, though types F and G are most common. This seems to indicate that the cause responsible for the light variation is independent of the physical state of the star. From the positions of the spectral lines, it is found that all these stars have variable radial velocities, the period of this variation being equal to that of the light variation. The two phenomena are therefore intimately connected. Supposing for the moment that these stars are binary systems, the maximum light is found to occur always approximately at the time when the brighter component (whose spectrum alone can be observed) is approaching us most rapidly, and the minimum when it is receding most rapidly. The constancy of the period of a Cepheid variable and the

variation of the radial velocity with the same period as the light variation suggest that such stars are double, consisting of two components whose orbital plane is inclined to the line of sight at a sufficiently small angle for eclipses to occur. If the two components are of equal brightness, a symmetrical light curve of the ζ Geminorum type would be obtained (Fig. 99);

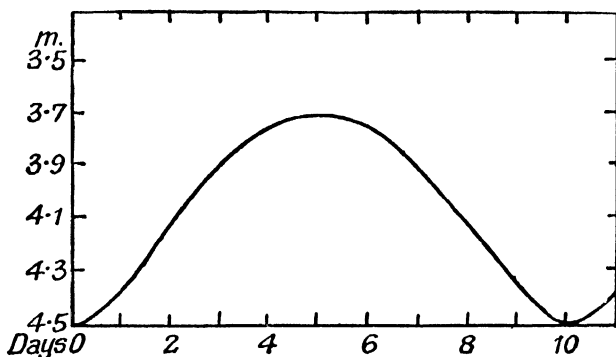

FIG. 99.—The Light Curve of ζ Geminorum.

if the orbit is markedly eccentric an unsymmetrical light curve would be obtained, the minimum not occurring midway between the two maxima, as in the normal δ Cephei type. On such a theory it would be expected that the light minimum should occur at conjunction when one star is obscured by the other and not at quadrature, and further, the light curve should show straight stretches, since at quadrature there would be no light variation. This forms a difficulty in the interpretation of the phenomena as due to eclipses which has not been successfully overcome; one explanation has been advanced which is based upon the hypothesis that a resisting medium exists around the two stars; this would brush back the atmosphere on the advancing side of the bright star and make it appear brightest when approaching most rapidly; another explanation supposes large tidal effects at periastron. But there is a still more serious difficulty in the way of the binary interpretation; the Cepheids have been found to be stars of great absolute brightness, several hundred times that of the Sun. The average Cepheid has therefore a volume between fifteen and twenty thousand times as great as that of the Sun, since the

surface brightness cannot be very different from that of the Sun. Now, adopting the binary hypothesis, it is possible, as in the case of a spectroscopic binary, to deduce the value of $a \sin i$ for the orbit; the average value of this quantity found for 15 Cepheids is 1,116,000 km., with a maximum of 2,000,000 km. The value of i cannot be very small or eclipses would not be observed: it follows that, interpreted as binaries, the radii of the orbits are less than one-tenth the radii of the stars themselves. A further difficulty is that the spectral type shows a continuous change throughout the variation; thus in the case of RS Boötis, period about nine hours, the type changes from F0 at minimum to B8 at maximum. The interpretation of this on a binary hypothesis is not clear.

It appears therefore that an alternative explanation must be sought. The most plausible explanation yet advanced is that the variations of radial velocity are due to periodic pulsations of the star and that these pulsations cause changes in the rate of emission of light. The greatest light would occur when the rush of hot gases from the interior was greatest and would therefore coincide, at least approximately, with the maximum velocity of approach. The change in the temperature of the star's atmosphere would coincide with a change of spectral type, and would take place when the star was hottest. At maximum brightness the spectrum would be of an earlier type than at minimum, when the star would be coolest. This is in accordance with observation. The theory also accounts naturally for the absence of a second spectrum.

This theory therefore provides an adequate explanation of the observed phenomena. The question arises as to how the pulsations are maintained—from whence comes the energy necessary to maintain pulsations with a total amplitude of the order of 2,000,000 km. This is a question which has not yet been satisfactorily answered; until such an answer is forthcoming the pulsation theory will not command universal acceptance, even though no equally plausible theory has yet been advanced.

216. The Luminosity-period Relation for Cepheids.—A remarkable relationship was discovered by Miss Leavitt between the absolute magnitude and length of period for

Cepheid variables. In the Small Magellanic Cloud many of these stars have been found. The distance of the Cloud is so large compared with its linear dimensions that all the stars in it may be assumed to be at the same distance without appreciable error. Their apparent magnitudes therefore differ from their absolute magnitudes merely by a constant, which depends upon the distance of the Cloud. Miss Leavitt found that for the Cepheid-type variables in the Cloud there was a definite relationship between the period of the light variation and the apparent magnitude of the star from which the period of any Cepheid variable in the Cloud could be deduced if its apparent magnitude had been determined.

In many stellar clusters occur variable stars which are usually termed cluster variables; the variation of these stars is essentially of the Cepheid type, though they include stars with periods much longer than are found amongst the group of stars to which the name Cepheid variable was originally applied.

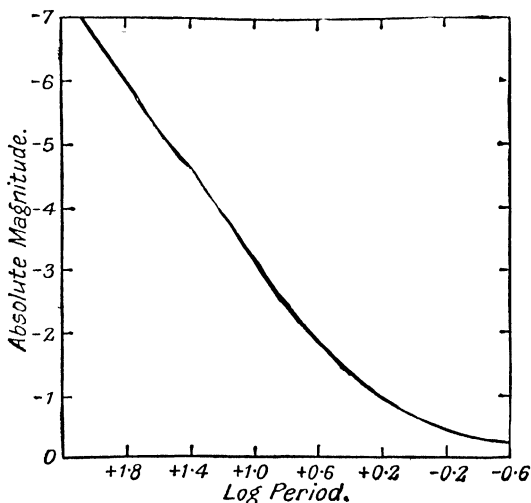

FIG. 100.—The Luminosity-period Relationship for Cepheid Variables.

Shapley found that such variables in any one cluster conformed to the same type of relationship connecting period and magnitude as the variables in the Magellanic Cloud, and it is logical, therefore, to assume that it is a universal characteristic of Cepheids. From a study of the near Cepheids, Shapley was able to assign an absolute magnitude to a definite period and

hence to fix a point on the curve enabling all the material available to be reduced to a common basis and a definitive curve connecting the absolute magnitude and the period to be constructed. This curve is shown in Fig. 100.

This relationship is of great importance. If the period of any Cepheid variable is observed, its absolute magnitude can be deduced. It is then only necessary to determine its apparent magnitude in order to obtain its distance. The accuracy of the distances so obtained far surpasses that of direct trigonometrical determinations and enables the distances of the Magellanic Cloud and of various stellar clusters to be derived with certainty.

217. Eclipsing Variables.—The last class of variable stars to be considered comprises the large number of stars which are definitely known to be binary systems, the variation in light being due to one component eclipsing the other. The extent of the eclipse and the corresponding variations in brightness depend upon the brightness of the two components, their relative size, and the inclination of their orbital plane to the line of sight. If this inclination is large, eclipses will not be visible to an observer on the Earth. The circumstances of the light variation, in fact, enable very definite conclusions to be drawn as to the nature of the system.

The light curves may be divided into four main classes :—

(i) There may be a series of equal minima, occurring at equal intervals. Such a curve could be produced by a system containing one dark body and one bright body, or two bright bodies of equal size and luminosity. If the orbit is not circular but elliptical, the major axis of the ellipse must coincide with the line of sight or the eclipses would not occur at equal intervals. The spectrum will indicate whether two bright bodies are concerned and the radial-velocity curve will decide whether the orbit is circular or elliptical.

(ii) There may be a series of equal minima, occurring alternately at two different intervals. Such a curve can only be due to two bodies equal in size and brightness, with an elliptical orbit whose major axis is not in the line of sight.

(iii) There may be a series of minima which are unequal but occur at equal intervals, the alternate minima being equal.

Such a curve must be produced by two unequally bright stars moving in a circular orbit or in an elliptical orbit whose axis is in the line of sight.

(iv) The minima and intervals may both be unequal but alternate ones equal. Such a curve would be given by unequally bright stars moving in an elliptical orbit whose major axis is not in the line of sight.

If the eclipses are partial the duration of the minima will be very short, whereas if they are total or annular the minima may remain constant for some time. Between the eclipses, the brightness will remain constant if the two stars are spherical and have uniform surface brightness, but if one or both components is elliptical or has a non-uniform surface brightness, there will be small variations in brightness between the eclipses. If the two components are not spherical, but are tidally distorted, there will be a continuous change in brightness from minimum to maximum and back to minimum, the light curve then being a representation of two superposed effects, the light variations due to the eclipses and those due to the rotations of the non-spherical bodies.

A general conception of the nature of the system can therefore usually be obtained from the light curve. By the application of mathematical methods it is possible, with a few simple assumptions, to deduce the ratio of the major axes of the two components, their ellipticities, the ellipticity of the orbit, the ratios of the axes of the two components, to the major axis of the orbit, the brightness of the two components in terms of that of the Sun, the ratio of their surface brightness, the inclination of the orbital plane to the line of sight, the mean densities of the two components, and the time of passage through periastron. If, in addition, the velocity curve is known from spectroscopic observations, the actual dimensions and densities of the components can be obtained. A knowledge of the parallax of the system further enables the absolute magnitudes and surface brightnesses of the two components to be deduced.

218. Examples of Eclipsing Variables.—(a) *Algol*. The regular variability of Algol (β Persei) was discovered by John Goodricke (1764–1786), although the name (the “demon” star) suggests that its variability was known to the Arabs long

before. It was certainly known to Montanari a century before Goodricke. The light curve is shown in Fig. 101. The magnitude is about 2.3 m. at maximum and remains practically at this value for several hours; it then decreases rapidly and falls by about 1.2 m. to 3.5 m. in five hours. On reaching the minimum, the magnitude immediately commences to

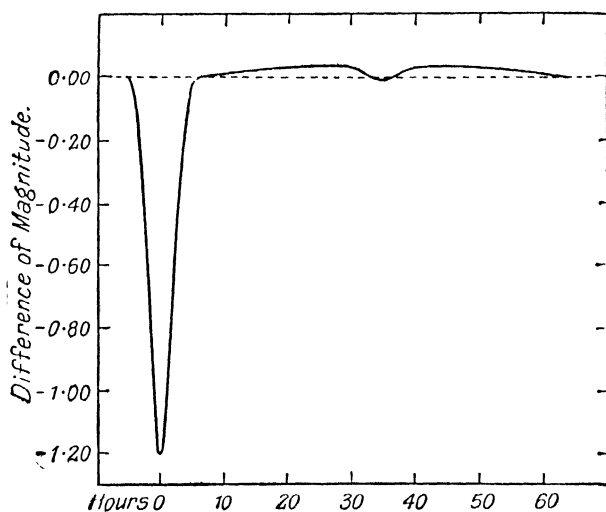

FIG. 101.—The Light Curve of Algol.

increase again and reaches its original value after a further period of five hours. About twenty-five hours later, there is a secondary drop in magnitude of about 0.05 m. The whole period is 2.867301 days, or nearly 69 hours.

From an inspection of the light curve the following information may be deduced. In each period there are two minima which occur at equal intervals; the two eclipsing bodies therefore move in a circular orbit or in an elliptic orbit whose axis is in the line of sight. The light does not remain constant for any length of time at the minima; the eclipses are therefore partial, for if they were total the light would remain appreciably constant during the passage of the one star in front of the other. Since one minimum is much deeper than the other, one of the components is bright and the other faint. The brightness between the two minima varies slightly; this suggests that the components are elliptical or are of non-uniform surface

brightness. If the former, the magnitude would be a maximum at quadrature, midway between primary and secondary minima; this is not the case, and the curve is not symmetrical about this point, so that both effects are concerned.

The mathematical discussion shows that the radii of the bright and faint bodies in terms of that of the orbit as unit are respectively 0.207 and 0.244, the faint body being therefore the larger. The light of the bright body (in terms of the maximum light of the system) is .925; that of the faint body, which is of non-uniform brightness, varies between 0.045 and 0.075. The angle between the normal to the orbit and the line of sight is about 82° . Radial-velocity observations confirm that the orbit is circular. Both bodies are slightly elliptical. The mean density of the system in terms of that of the Sun as unity is 0.07. The parallax of the system is estimated as $0''.032$; this would make the total light of Algol about 200 times that of the Sun, whilst the darker body has a surface intensity ten times that of the Sun.

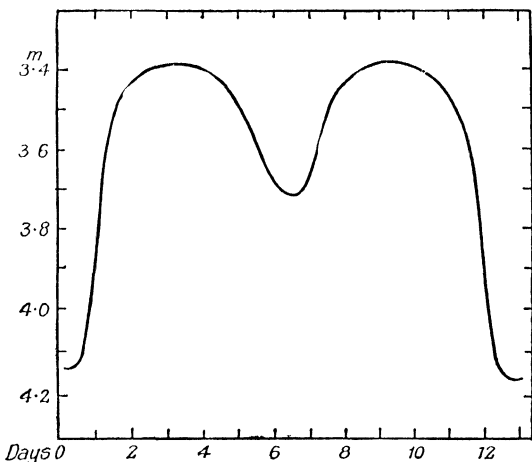

FIG. 102.—The Light Curve of β Lyrae.

(b) β Lyrae.—The light curve of this star, whose variability was also discovered by Goodricke, in 1784, is shown in Fig. 102. It has two unequal minima separated by two equal maxima and is characterized by a continuous variation in light, there being no period of steady luminosity either at maximum or minimum. The period is 12.916 days; the maximum magnitude is 3.4 m. and the ranges at primary and secondary minima are respectively 0.97 m. and 0.45 m. The continuous variation of light is due to the large eccentricity of figure of the two com-

ponents, so that, even though the eclipses are total, the light does not remain constant at the minima. The orbit is very nearly circular, the minima being nearly equidistant. The spectral lines due to both components can be observed in the spectrum of the system, the two components being of types B5 and B8. The mathematical investigation shows that the components are strongly ellipsoidal, the ratio of the other two axes to the major axis being 0.76 and 0.69 respectively. The inclination of the orbit is about 62° . The radii of the brighter and fainter components in terms of that of the orbit are respectively 0.27 and 0.68. The ratio of the surface intensity of the brighter to that of the fainter body is about 9.4 to 1. Both bodies have very small density.

This system therefore consists of two stars of early type and low density revolving about one another nearly—or possibly actually—in contact. Under their mutual attracting influence they are tidally distorted, and to their elliptical shape the peculiarities of the light curve are mainly due. A hypothetical representation of the system is shown in Fig. 103, in

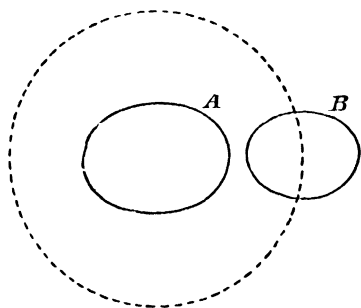

FIG. 103.—The System of β Lyrae.

which A, B are the fainter and brighter components respectively.

219. Remarks on Eclipsing Variables.—Whilst the long-period variables are chiefly to be found amongst the red, late-type stars, the eclipsing variables occur most frequently amongst stars of early type, and particularly amongst types B and A. Out of 93 stars examined, 18 were of type B, 54 of type A, 12 of type F, 8 of type G, and only one of type K. The mean densities of the eclipsing variables are small; of these 93 stars, only one had a density exceeding that of the Sun. The mean density for the B-type stars was 0.12 in terms of the Sun's density as unit, and that of the A-type stars was 0.21. The extreme densities, both high and low, are to be found amongst types F and G.

The range of variation in magnitude at principal minimum is connected with the relative sizes of the two components. If the range exceeds two magnitudes, the faint star is almost certain to be the larger; if the range exceeds one magnitude, the faint star is probably the larger; but if it is less than 0.7 m. the faint star is either equal to or smaller than the bright star. On the other hand, in the majority of systems examined, the brighter component has a somewhat greater mass than the fainter, and in no case has it a less mass. Therefore in general the fainter component is larger, but less massive, and therefore has a smaller density; on the average the density of the fainter star is about one-third that of the brighter. The fainter components are usually of a later spectral type than their primaries, so that the eclipsing variables provides instances of bodies of late type with low densities.

The eclipsing variables are not uniformly distributed in space, but show a marked condensation towards the plane of the Milky Way, though not so marked as in the case of the Cepheid variables.

If the inclination of the orbital plane of an eclipsing variable is large, the eclipses are not visible, but the binary nature is detected by the spectroscopic observations and the system is then termed a spectroscopic binary. It is interesting to note that for spectroscopic binaries and visual double stars there is a progressive increase of eccentricity with period. This is indicated in the following table, which represents the mean of a large number of systems:—

	Period.	Eccentricity.
Spectroscopic Binaries . . .	3 days	0.05
	8 "	0.15
	23 "	0.32
	1½ years	0.35
Visual Binaries	31 "	0.42
	74 "	0.51
	170 "	0.54

220. **The Origin of Binary Systems.**—The principal phenomena to be taken into account in formulating a theory

of the origin of binary systems are (i) the great relative number of such systems, (ii) the correlation between eccentricity of orbit and length of period to which we have just referred, (iii) the correlation between length of period and spectral type, the short-period spectroscopic binaries being most numerous amongst early-type stars and the long-period visual binaries amongst late-type stars.

One theory which has received much support supposes that the two stars of a binary system were originally independent, but that having at some time approached one another sufficiently closely, they were captured by their mutual gravitation. The theory has been worked out in great detail, but the large number of binary systems seems a fatal argument against it. From the density distribution of stars in the neighbourhood of the Sun as determined by parallax observations, it has been estimated that two stars will only approach one another within 200 astronomical units, on the average, once in 10,000 million years. It would on this theory be even more difficult to account for triple systems, many of which are known.

Another theory attributes the origin of binary systems to the fission of an original parent star—the genesis being thus somewhat similar to that of the Earth-Moon system. The parent body, in its primitive state, is supposed to have been in rotation and gradually to have contracted. The rate of rotation would have increased as the body contracted. A certain stage was at length reached when the body became first pear-shaped and then dumbbell-shaped and subsequently divided into two detached masses. These were at first nearly in contact, as in the case of the two components of β Lyrae. Tidal friction would then cause the distance apart of the stars gradually to increase.

The objections to this theory are that the critical density at which fission takes place exceeds that of many eclipsing binaries and that tidal friction is not competent (when the masses of the components are equal) to increase the initial period more than a few-fold, whereas we find in nature periods ranging from a few days to thousands of years.

At present, therefore, there is no theory which can be held to explain at all satisfactorily the various phenomena presented by binary systems. (*See also* § 244.)

CHAPTER XIV

THE STELLAR UNIVERSE

221. **The Milky Way or Galaxy.**—The Milky Way or Galaxy is the name given to the luminous belt of stars which encircles the heavens, nearly in a great circle. The Galactic Plane is the plane passing as nearly as possible through the centre of this belt. The Milky Way passes in the northern sky within about 30° of the North Pole, runs through the constellations of Cassiopeia, Perseus, and Auriga to the horns of Taurus, where it crosses the ecliptic near the solstice at an angle of about 60° . Thence it passes between Orion and Gemini, through Monoceros to Argo, Crux, and the feet of the Centaur. Here it divides into two branches, the brighter of which passes through Ara, Scorpio, the bow of Sagittarius, and Aquila to Cygnus, where it rejoins the other branch. Both the width and the brightness of the Milky Way vary greatly from one point to another. In its widest part, between Orion and Canis Minor, it has a width of about 45° ; in other places the width is as small as 3° or 4° . The densest part of the Milky Way is in the star clouds in Sagittarius (Plate XVIII). In the denser parts of this region the plate shows a continuous background of stars, the images of which are too close to separate.

The northern galactic pole is situated in R.A. 190° , Dec. $+28^\circ$, the southern galactic pole being therefore in R.A. 10° , Dec. -28° . The position of a star may be defined with reference to the galactic plane. The galactic latitude of a body is defined as the angular distance of the body north or south of this plane. The galactic longitude is defined as the angular distance of the body measured along the galactic plane from the point of intersection of the galaxy with the equator in R.A. 280° , Dec. 0° . These galactic co-ordinates are of import-

ance in many stellar investigations, for the galactic plane is the fundamental plane of reference for sidereal astronomy and corresponds in this respect to the plane of the ecliptic of planetary astronomy. A further advantage of galactic co-ordinates is that they are not affected by the precession in the equinoxes, so that changes in the galactic co-ordinates of a star determine at once the star's proper motion.

222. The Galactic Condensation of the Stars.—The fundamental importance of the galactic plane in sidereal astronomy is due to the fact that it forms a plane of symmetry for the stellar universe. The stars, both bright and faint, crowd towards it. This was first pointed out in the case of the brighter stars by Sir William Herschel, and Schiaparelli, Seeliger, and others have extended the relationship. The following table gives the mean densities of the stars per square degree for galactic zones of 20° width, for stars down to magnitude limits of 6 m., 9 m., and 14 m. respectively :—

Galactic Latitude Zones.	Densities of Stars down to various Limits of Magnitude.		
	6·0 m.	9·0 m.	14·0 m.
+90° to +70°	0·113	2·78	107
+70° „ +50°	·122	3·03	154
+50° „ +30°	·124	3·54	281
+30° „ +10°	·145	5·32	560
+10° „ -10°	·160	8·17	2,019
-10° „ -30°	·154	6·07	672
-30° „ -50°	·129	3·71	261
-50° „ -70°	·124	3·21	154
-70° „ -90°	·125	3·14	111

The values in the last column are derived from Herschel's "star gauges," or counts of stars visible in a definite area in the field of his 18-inch reflector.

From this table it will be seen that the naked-eye stars exhibit a slight but perfectly definite preference for the galaxy, apparently indicating that a proportion of the bright stars which are visible in the Milky Way are either situated in it

and form part of it or are in some way definitely connected with it. Down to a limit of the ninth magnitude, the stars are nearly three times as dense in the Milky Way as at the galactic poles, whilst for the stars of Herschel's gauges the ratio is nearly twenty to one, the large ratio being due to the great number of faint stars in the Milky Way. The stellar system, considered as a whole, is therefore very markedly flattened towards the Milky Way.

A comparison of the densities in the above table for corresponding zones of north and south galactic latitude shows that in each case the density in the southern zone is the larger. The explanation of this result is that our solar system is situated somewhat to the north of the galactic plane. A close study of the course of the Milky Way in the heavens confirms this view. Struve found that it does not actually trace out a great circle on the celestial sphere, but a small circle at a distance of about 88° from the south galactic pole.

The galactic condensation just considered was a mean value for stars of all spectral types. The condensations for the individual types show very considerable variations. In the following table are given the numbers of the bright stars of different types, down to a visual limit 6.5 m., in eight zones of galactic latitude, so chosen as to have approximately equal areas. The table indicates therefore the distribution of the stars nearest the Sun.

Mean Galactic Latitude of Zone.	B	A	F	G	K	M	Total.
$^{\circ}$ + 62.3	8	189	79	61	176	56	569
+ 41.3	28	184	58	69	174	49	562
+ 21.0	69	263	83	70	212	57	754
+ 9.2	206	323	96	99	266	77	1,067
- 7.0	161	382	116	84	239	45	1,027
- 22.2	158	276	117	100	247	69	967
- 38.2	57	161	94	59	203	59	633
- 62.3	29	107	77	67	202	45	527

It will be seen that the stars of type B exhibit a strongly marked crowding towards the galaxy but that with successive types the distribution in the various zones becomes more

uniform until with type M there is very little evidence of galactic condensation. If the pole of the plane of concentration of the B-type stars is determined, the value R.A. 182° , Dec. $+ 28^\circ$ is obtained, which is very near the position of the galactic pole.

The most remarkable concentration is shown by the small class of stars known as Wolf-Rayet stars, which we have seen may be a state through which all novæ must pass. With the exception of some Wolf-Rayet stars in the Magellanic Clouds, the remainder are all in the Milky Way and the pole of their plane of condensation coincides exactly with the galactic pole.

Other classes of objects which show strong galactic concentration are eclipsing variables, Cepheid variables, and gaseous nebulae.

223. The Distance of the Milky Way.—The distances of the individual stars composing the Milky Way cannot be determined by direct trigonometrical methods. Some idea of the distance of the Milky Way can nevertheless be obtained indirectly. If we assume that a condensation of any class of stars towards the Milky Way indicates that some stars of such class belong to the Milky Way, then it is certain that stars as bright as 9.0 m. belong to the Milky Way; a star whose luminosity is 10,000 times that of the Sun would appear of the ninth magnitude at a distance of 5,000 parsecs. It may therefore be concluded that the nearest parts of the Milky Way are not more distant than this limit. If, as we have seen is probable, some of the sixth-magnitude stars belong to the Milky Way, the distance is reduced to 1,200 parsecs.

We can get some more definite information from the Cepheid variables, whose marked galactic concentration would appear to indicate that they are connected with the Milky Way. In § 216 it was explained how the distance of any Cepheid variable can be determined with accuracy when its period is known. Using this method, Shapley has determined the distances of the known Cepheids. The distances so found range from about 100 parsecs to 6,000 parsecs, but inasmuch as there are undoubtedly many Cepheid variables which still await discovery, and as the nearest are most likely to be discovered first, it is not improbable that there are Cepheids at distances

much greater than 6,000 parsecs. But the important point is that the known Cepheids are fairly uniformly distributed in distance between the two limits.

Some investigators have supposed that the Sun occupies a nearly central position in a fairly uniformly distributed and spherical local system of stars outside which lies the Milky Way, with a form somewhat like that of an anchor ring. Recent investigation has modified this conception, as we shall see when dealing with stellar clusters. The distribution of the Cepheid variables would seem to indicate rather that our stellar system is strongly oblate or lens-shaped and that the great star-density in the Milky Way is due at least partly to the greater distance to which the system extends in that direction. This conception is not opposed to the possibility of the existence in the Milky Way of numerous "star clouds" of great star-density and at very great distances. That such star clouds exist is rendered probable by the example of the Magellanic Clouds (Plate XIX). Although the latter may be isolated portions of the Milky Way, it is possible that, in view of their high galactic latitude, they may not be related in any way to it. They contain many Cepheid variables, and this fact has enabled their distance to be determined as about 10,000 parsecs. There are many similar aggregations in the Milky Way; Easton has discussed the star-densities in some of these regions and in adjacent regions just outside and found that at the fourteenth magnitude an overwhelming proportion of the stars were associated with the local aggregations. Recently, Cepheid variables and other stars of high luminosity have been found amongst the fifteenth-magnitude stars of the galactic clouds, indicating that these clouds are at a distance of at least 15,000 parsecs. Nevertheless, there is no reason to suppose that these clouds are more than local aggregations in the general oblate system, and it is very probable that the Cepheid variables extend to distances as great as or greater than many of these clouds. If this view is correct, we ought not to speak of the distance of the Milky Way, but rather of the depth or extent of the sidereal system in the galactic plane.

224. Stellar Clusters.—In addition to the large-scale aggregations of stars in the Milky Way which we have been con-

sidering and of which the star clouds in Sagittarius (Plate XVIII) may be cited as an illustration, there are also known many aggregations of a different nature, frequently showing a regular and definite configuration. These are called star clusters. The typical star cluster, such as the cluster in Hercules (Plate XXI, *b*) is spherical in shape with a density decreasing from the centre outwards, at first rapidly and then more gradually ; the boundary of the cluster is not sharply defined in general, the density falling gradually to zero ; superposed upon the cluster are the field stars (i.e. the stars which would still be seen in the same region of the sky if the cluster were removed), so that it is only possible to define approximately the boundary by careful counts for the determination of the relative density. Clusters of this type are termed globular clusters. But regarding a true cluster as any group of stars which have a physical relationship with one another, there are two other types which must be included under the general designation of star-cluster. One of these types is illustrated by the Præsepe cluster ; it consists of a group of stars with a somewhat irregular boundary but less condensed towards the centre and with fewer stars than the typical globular cluster. Such clusters are termed open clusters. The other class consists of groups of isolated stars, each member of which has a velocity along the same direction in space and of the same magnitude. The Pleiades stars form one example of such a group of stars having a common motion ; there is undoubtedly a physical connection between them (Plate XX). Another example is given by the Taurus cluster, which comprises some of the stars in the Hyades and other neighbouring stars ; these stars are in the immediate neighbourhood of the Sun, and their relationship can only be established by the identity of their motions. Thirty-nine members of the Taurus cluster are known ; all of these are stars much brighter than the Sun, and it is therefore probable that many fainter stars belong to it which have not yet been identified. These last two classes are probably analogous and differ only in distance from us. The first class possesses somewhat different properties and has been more extensively studied.

225. Globular Clusters.—The globular clusters, of which

the Hercules cluster (Plate XXI, *b*) is the typical example, form a limited class of objects, the number known being about ninety-five. Their distribution shows some important features; in galactic longitude, they mostly occur between longitudes 235° and 5° , in the constellations of Ophiuchus and Sagittarius, whilst between longitudes 41° and 195° there is not a single one. The distribution is approximately symmetrical with respect to the line 145° to 325° . In galactic latitude the distribution is also irregular; whilst it is approximately symmetrical with respect to the galaxy, there is an almost complete absence of clusters from a zone extending from $+10^\circ$ to -10° galactic latitude. In this respect they differ from the other two classes of clusters, which are concentrated towards the galactic plane and are most numerous in the central zone. The globular clusters are most numerous just outside this central zone. The physical meaning of this zone of avoidance is not known, but it has been conjectured that if a globular cluster should enter the central zone in the neighbourhood of the large masses of matter concentrated in the star clouds of the Milky Way, the effect of gravitational attraction would be to destroy the cluster, which would ultimately appear as a loose aggregation of stars—the typical open cluster.

The distances of the globular clusters can be estimated with great accuracy by indirect means. The investigations of Shapley at the Mount Wilson Observatory have resulted in several mutually concordant methods, with the aid of which the distances of all the clusters have been determined. The foundation upon which these methods are built is the luminosity-period relation which holds for Cepheid variables. In many of the clusters variable stars occur whose light curves indicate that they are typical Cepheids. A determination of their periods and apparent magnitudes enables the distance of the cluster to be at once deduced. For such clusters, it is then found that there is a definite correlation between apparent diameter and distance. This implies that the globular clusters do not differ greatly in actual linear dimensions, and it therefore becomes possible to determine with some accuracy the distance of any globular cluster by measuring its apparent diameter. The distance so determined can be checked in another way. Shapley finds that the mean absolute magni-

tude of the brightest stars in the cluster (say the twenty-five brightest) has practically a constant value for different clusters, and it is not unreasonable to suppose that this result holds for all clusters. Such stars are typical giant stars, and it is not probable that the absolute magnitudes of the giant stars differ greatly wherever they occur in the universe. For any cluster, therefore, in which no variables have been discovered it is only necessary to determine the apparent magnitudes of the twenty-five brightest stars in order to be able to deduce the distance, the corresponding absolute magnitude of these stars being known. By a combination of these three methods the distances of the globular clusters have been determined with a relatively small uncertainty.

The nearest clusters are 47 Tucanæ and ω Centauri, which have parallaxes of $0''.000148$ and $0''.000153$ respectively, corresponding to distances of about 7,000 parsecs or 22,000 light-years. N.G.C. 7,006, on the other hand, has a parallax of $0''.000014$, corresponding to a distance of 67,000 parsecs or 220,000 light-years. In this cluster, a star of the brightness of Sirius would appear to us as only of the seventeenth magnitude. The diameters of the clusters are of the order of several hundred light-years.

That the bright stars in the globular clusters are in fact giants and not dwarfs has been established by photographing the spectra on special photographic plates, sensitive in the blue and the red but insensitive in the green-yellow region. In this way spectra divided in the middle are obtained and the relative intensities of the blue and red portions can be estimated. Giants and dwarfs of the same spectral type show a markedly different intensity ratio: it is found that many giants are present amongst the cluster stars.

226. The System of the Globular Clusters.—The determination of the distances of the globular clusters enables their actual positions in space to be assigned. Taken together, they form a system whose centre lies in the Milky Way in the direction of Sagittarius and at a distance of about 20,000 parsecs or 65,000 light-years. The greatest diameter of the system outlined by the clusters is about 300,000 light-years. Our solar system therefore occupies a markedly eccentric

position in this larger system. This accounts for the unequal distribution of the clusters in galactic longitude.

These investigations have necessitated some revision of the views which were held only a few years ago with regard to the structure of the universe. The concentration of the clusters towards the Milky Way and their symmetrical arrangement with respect to it indicate a definite relationship. We must therefore conclude that our stellar universe has a longest diameter of at least 300,000 light-years. Our solar system lies somewhat to the north of the central plane of this system and about 60,000 light-years from its centre. It seems probable that the Sun is near the centre of a large local cluster situated eccentrically in this larger system. Investigations of star density in the neighbourhood of the Sun have shown that the density falls off with distance in all directions. This was formerly taken as an indication that the Sun was near the centre of the Universe. In the light of recent discoveries this view must now be revised. The evidence in support of the hypothesis that such a local cluster exists is strong and is summarized in the next section.

227. The Local Cluster.—We start from the hypothesis that the stars in the neighbourhood of the Sun (i.e. mainly those which are contained in the various catalogues of star positions and proper motions) fall into two classes: (1) members of a moving local cluster of limited extent; (2) members of the general galactic system. The distribution of the B-type stars in the neighbourhood of the Sun (within about 500 parsecs) has been studied by Charlier. On the above hypothesis it must be assumed that the B-type stars belong mainly to the local group, for stars of this type do not increase in number with decreasing apparent magnitude as rapidly as do other types and they are very infrequent beyond a distance corresponding to apparent magnitude 7.5. The system outlined by these stars has its centre in the constellation Carina, in a direction which is nearly at right angles to the direction of the centre of the general galactic system, and at a distance of about 88 parsecs from the Sun. The Sun is a few parsecs above its central plane of symmetry. The pole of the central plane of the system of the B-type stars was found by Charlier

to be in R.A. 184.3° , Dec. $+28.7^\circ$, whilst the pole defined by the Milky Way clouds is in R.A. 191.2° , Dec. $+27.4^\circ$. This difference is a real one and indicates an inclination of the central plane of the local system to the plane of the galaxy. The reality of the difference is established by plotting down in projection the positions of the B-type stars: the brighter stars are found to be concentrated along the projection of the central plane of the local cluster, whilst the faint ones are concentrated along that of the galactic plane. The pole of the true central plane of the local cluster is in this way found to be in R.A. 178° , Dec. $+31.2^\circ$, corresponding to an inclination of the central plane to the galactic plane of about 12° . It is significant that Gould's belt of bright stars, defined by the naked-eye stars, coincides closely with this central plane, whilst fainter stars, to the ninth magnitude, give the same pole for the Milky Way as is given by the galactic clouds. In support of this hypothesis of a local cluster, it may be mentioned that in many typical globular clusters the existence of what may be termed a "galactic plane" has been found.

It appears from Shapley's researches that the cluster stars comprise most of the B-type stars, a majority of the A-type stars brighter than about the seventh magnitude, and a number of the redder stars in the neighbourhood of the Sun. The stars of the general galactic system which interpenetrate it include a few stars of types B and A, a majority of the redder stars, Cepheid variables, etc. The greater degree of concentration towards the galactic plane of the early than of the late type stars is thus explained, for a greater proportion of the early-type stars belong to the local cluster. The motion of the local cluster through the surrounding field may possibly give an explanation of the phenomenon of star-streaming.

228. The Absorption of Light in Space.—For many astronomical observations, it is necessary to know whether there is any appreciable absorption or scattering of light in space. Is there cosmic dust distributed through space in sufficient density to produce an appreciable amount of absorption when light travels through it for a great distance? If such absorption does occur, it will be greater for light of short wave-length than for light of long wave-length, and the effect

will be to make distant stars appear relatively redder than near stars and to increase their mean colour-index. An extremely small density of matter would be required to cause an increase in colour-index of 0.00015 m. for every parsec distance travelled by the light. In a distance of 10,000 parsecs this would result in an increase in colour-index of 1.5 m., so that, even with this small amount of absorption, a star at such a distance could not have a negative colour-index. This indicates the argument by which it is possible to conclude from the known distances of stellar clusters that absorption in space is either non-existent or is so small in amount that it is of no importance to the astronomer. In clusters whose distance is greater than 10,000 parsecs, stars with negative colour-indices occur, and in as large a proportion as in the nearer clusters. Since there is no reason to suppose that uniformity of conditions and of stellar phenomena does not prevail throughout the galactic system, it is natural to assume that the stars in the clusters are similar to those adjacent to the Sun. The similarity in the range and proportions of the colour-indices therefore indicates that the absorption of light in space is quite negligible. This conclusion must not be taken, however, to prove the non-existence of absorption by isolated nebulous clouds of matter. Conclusive evidence of such absorption is in fact known and is illustrated by Plates XXIII and XXIV.

Plate XXIV (frontispiece) shows a dense star region in Ophiuchus. In the lower left-hand portion of the photograph is seen a dark lane almost entirely devoid of stars. At its boundaries the star density falls off with remarkable suddenness. This lane is connected with the nebulosity near the centre of the photograph. There is no doubt that between the Earth and the stellar background is an absorbing cloud of gas, which is non-luminous and which entirely cuts off the light from the background of stars. This dark nebula, as it may be called, is directly connected with the luminous nebula at the centre. The few stars appearing in the dark lane are stars nearer to the Earth than the absorbing matter.

In Plate XXIII is represented a portion of the Southern Cross and the "hole" in the Milky Way known as the Coal-Sack. This is undoubtedly another instance in which absorbing matter is present, although its boundaries are not so

sharply defined as in the case of the dark lane illustrated in Plate XXIV.

229. Open Clusters.—The open clusters, in which class may be included the group of stars having a common motion, differ in several respects from the globular clusters. Their shape is more irregular and they are frequently associated with nebulosity, whilst the globular clusters never are. They are strongly condensed towards the galactic plane, but in galactic longitude their distribution is far from uniform; they are most numerous at the opposite point in the galactic plane to that in which most of the globular clusters are found. Many of their distances have been determined and vary between 400 and 16,000 parsecs, with a mean value of about 6,000. The number of stars in them is far fewer than in the globular clusters and their angular size is in many instances greater.

230. Nebulæ.—Nebulæ may be divided into three main classes, which must be considered separately.

(1) *Irregular Nebulæ.*—Of these, the Great Nebula in Orion is the most conspicuous example. This class comprises nebulæ of many varied shapes, whose names are often given from a more or less striking resemblance to some terrestrial object, such as the Dumbbell Nebula, the Crab Nebula, the North America Nebula, the Keyhole Nebula, etc. In the same category may be placed the nebulous backgrounds, obviously associated with stars, such as the nebulosity around the Pleiades (Plate XX) and in the constellation of Taurus and also the dark nebulæ (§ 228 and Plate XXIV). These irregular nebulæ occur mainly in the neighbourhood of the galaxy and in many cases show undeniable connection with certain stars.

(2) *Planetary or Gaseous Nebulæ.*—These were first classified as such by Sir William Herschel, though he did not originally recognize their nebulous nature. “We can hardly suppose them to be nebulæ,” he says; “their light is so uniform as well as so vivid, their diameters so small and well defined, as to make it almost improbable that they should belong to that species of bodies.” He considered that they might be planets attached to distant suns, but later recognized that this supposition was untenable. Their spectra present many analogies to

the spectra of the Wolf-Rayet stars and, like the latter, they occur almost exclusively in the Milky Way.

(3) *Spiral Nebulæ*.—These constitute by far the most numerous class. Their discovery was the one striking achievement of the great Parsonstown reflector, constructed by Lord Rosse. Curtis estimates that the number of them which it is possible to photograph with the 36-inch Crossley reflector of the Lick Observatory lies between 700,000 and 1,000,000. By far the most conspicuous object of this class is the great nebula in Andromeda, easily visible to the naked eye as a small blurred patch, very different from a star in appearance (Plate XXI, *a*). It was the only nebula discovered before the invention of the telescope. Photographs show it to consist of a bright central nucleus, with long, spiral, nebulous arms wreathing round it. The spiral nebulæ that we know are placed at all inclinations to the line of sight. Many are seen perpendicular to the plane of the spiral arms; in this case, and in others, the two arms are clearly seen starting out from opposite edges of the central nucleus. Two examples of spiral nebulæ seen broadside on are shown in Plate XXII. Some, again, are viewed edge on, and in these the spiral arms are seen as a narrow line, evidence that they lie in one plane. This line is seen dark where it crosses in front of the central nucleus, owing to the absorption which the light from the latter undergoes in passing through the arms.

231. *Irregular Nebulæ*.—In this class must be included not only the brighter objects, such as the Orion (Plate XX, *b*), Omega, and Keyhole nebulæ, but also the extended nebulous backgrounds which have been photographed by Barnard and others, in the star clouds of the Milky Way and particularly in the constellations of Taurus, Scorpius, and Sagittarius. Of the same nature must be many of the dark spaces in the Milky Way (Plates XXIII and XXIV). There are many regions in the Milky Way where the star-density as shown on photographs is very small, whilst in adjacent regions it is very great, the boundary between the regions of large and small density being usually sharply defined. At first it was thought that the regions of small density were holes in the Milky Way, but it is now certain that they are due to the presence of dark nebulæ

lying between us and the Milky Way star clouds and cutting off the light from the latter. Only the nearer stars are seen in projection on them. The nebulosity is often apparent at the edges of these dark regions, and they are always found in portions of the sky where nebulosity abounds. Some of these dark nebulae give the appearance of curved lanes carving their way through dense starry regions, the nebulosity becoming visible at the end (Plate XXIV). Sir William Herschel was the first to point out the tendency of gaseous nebulae to sweep clear a space amongst the stars, this phenomenon being the same as that under consideration.

These irregular nebulae occur almost exclusively in the Milky Way. In many cases, it seems probable from the evidence of photographs that they are actually associated with the distant galactic star clouds; in others, as in the case of the Orion nebula and the Pleiades nebulosity, the stars are definitely in the midst of the nebula (Plate XX). The great brightness of some of these stars appears to indicate that their distance is not very great; such parallax determinations as are available support this statement—the parallax of the Orion nebula, for instance, having been determined as $0''.005$.

The spectra of nebulae of this class consist of a line emission spectrum superposed upon a weak continuous spectrum. The typical spectrum contains lines of hydrogen and helium together with certain characteristic lines which do not occur in the spectra of known terrestrial elements: these lines are attributed to a hypothetical element called "nebulium." It is possible, however, that two elements are concerned in their production, for the relative intensities of the lines denoted N_1 and N_2 is the same in all nebulae, whilst the relative intensities of N_1 and N_2 to the line N_3 vary with different nebulae and sometimes even within the same nebulae.

The most important irregular nebula is that in Orion (Plate XX, *b*), which long-exposure photographs show extends over an area of about 45° in declination and of two hours in right ascension. Owing to its large size and brightness it has been extensively studied. Spectroscopic observations, as well as photographs taken with and without colour filters, have established that the distribution of the various gases responsible for the emission lines in the spectrum is not uniform through-

out the nebula: the relative intensities of different parts of the nebula vary according to the nature of the colour filter used. The radial velocities at different points of the nebula have been determined. The velocity varies from point to point. After correcting the observed values for the solar motion it is found that although the nebula as a whole has no appreciable velocity in the line of sight, yet there are irregularities of speed in certain portions of the nebula amounting to as much as 10 km. per sec. There are also great collective movements: with respect to the mean velocity, the south-west region is approaching at a speed of about 5 km. per second and the north-east region is receding at about the same rate. Such movements may indicate a rotatory motion about a line south-east to north-west. The stars in the nebula have the same motion as the nebula.

By measuring the breadth of the emission lines of the nebula and applying the laws of the kinetic theory of gases, it has been estimated that the bright double line with wave-length 3,727 belongs to an element with an atomic weight about 3 and the nebular line 5,007 to another with a smaller atomic weight. These considerations also indicate a temperature of about 15,000°.

The small radial velocity of the Orion nebula appears to be a general characteristic of the irregular nebulae. All whose radial velocities have been determined have been found to have only a small velocity.

232. Planetary Nebulae.—This class includes small nebulae of regular shape and outline which are not spirals. In the telescope, such a nebula in general appears as an object with a sensible disc without a central condensation and similar therefore to one of the outer planets; hence the name. But many nebulae of this class show a pronounced central condensation. Their apparent diameters vary between 15' and a few seconds. In this class should also be placed the ring nebulae and nebulous stars. All these objects show a strong concentration towards the Milky Way, though a few may be found in high galactic latitudes. The smallest of them, and therefore probably on the average the most distant, are found in the Milky Way.

Many planetary nebulae have a nucleus of sufficient sharpness to enable the parallax to be determined by the ordinary methods. The parallaxes of several nebulae have already been obtained; these are naturally comparatively near objects, their distances being of the order of 50 parsecs. The parallax being known, the absolute magnitudes of the central nuclei and the linear diameters of the objects can be deduced. The central nuclei are thus found to have absolute magnitudes ranging from about 7 m. to 10 m. and are therefore dwarf stars. The diameters of the nebulae are of the order of about 6,000 astronomical units (about 0.09 light-years), the smallest being 1,350 units. For comparison, it may be noted that the diameter of the orbit of Neptune is about 60 units.

The number of planetary nebulae at present known is about 150. Their velocities have been measured in many cases and average about 40 km. per second, a value which, though much smaller than that found for spiral nebulae, is greater than that of the irregular nebulae. There are a few individual velocities which greatly exceed this amount; thus N.G.C. 6,644 has a velocity of 202 km. and N.G.C. 4,732 of 136 km. The velocities do not show a preference for any particular direction. In many cases there is evidence of internal motion or of rotation: particularly in those nebulae whose boundary is elliptical is there strong evidence for rotation about the shorter axis. The rotational velocity is greatest at the centre and decreases outwards. Curtis has used these results to obtain an estimate of the masses of several nebulae and obtains values ranging from 4 to 150 times the mass of the Sun.

The spectra of the planetary nebulae are closely related to those of the Wolf-Rayet stars. The relationship may be illustrated by a comparison of the two objects N.G.C. 6,572 and B.D. + 30° 3,639, investigated by Wright. The former of these is a planetary nebula with a nebulous nucleus; the latter is a Wolf-Rayet star surrounded by a weak, nebulous shell of apparent diameter 7". The spectrum of this shell is identical with that of the planetary nebula, whilst the nucleus of the latter has a typical Wolf-Rayet spectrum. The principal nebular lines are absent from the spectrum of the nucleus, whilst on the other hand the nebula itself does not show the usual bands associated with Wolf-Rayet stars. This relation-

ship is typical, and a gradual transition in spectra is indicated through successive stages, from the typical planetary nebula without a distinct nucleus to the nebula with a nebulous nucleus, thus to the star with a nebulous shell, and finally to the typical Wolf-Rayet star with no indication of nebulosity. As in the case of the irregular nebulae, it is frequently found that the various elements which together produce the observed spectrum of a planetary nebula are not uniformly mixed throughout the nebula, in the spectra of some portions certain lines predominating and other lines in those of other portions.

In view of the relationship between planetary nebulae and Wolf-Rayet stars indicated by their spectra, the difference in the average velocities of the two classes of objects is somewhat surprising. The latter have a low velocity, smaller than that of the B-type stars, averaging about 6 km. per second, whilst we have seen that the former have velocities five or six times this value. Ludendorff has shown that in the case of the B-type stars those of largest mass possess on the average the largest velocities. The masses of the planetary nebulae are undoubtedly greater than the average star masses, so that a similar result would appear to hold for these objects, and it would then seem that their occurrence in the scheme of stellar evolution is in some manner conditioned by their large mass.

233. Spiral Nebulae.—As we have already remarked, the spiral nebulae are by far the most numerous class of nebulae. Their distribution with respect to the galactic plane is remarkable and not similar to that of any other class of object. They are never found in or near the galaxy; there are many more in north than in south galactic latitudes, and they are most numerous in the neighbourhood of the north galactic pole. In galactic longitude, the distribution is also far from uniform; they are mainly clustered in that portion of the sky which is opposite to the region in which the globular clusters are most numerous.

The radial velocities of many spiral nebulae have been determined, and with few exceptions these velocities are large, in some cases surprisingly large. Several have been found to have velocities exceeding 1,000 km. per second. No other class of celestial object has velocities which at all approach these

figures. What is even more surprising is that these large velocities are in every case velocities of recession. This result must be of fundamental significance, but the precise interpretation is at present obscure. On one theory which considers the spirals as other universes comparable with our own galactic system it is explained by assuming that these systems—our own included—have velocities of several hundred km. per second, and the observed velocities are velocities relative to our system. On the theory which considers them as definitely associated with and part of our universe, it is supposed that they are in some way repelled from the galactic plane.

In several spirals evidence of internal motion has been obtained. Many of the nuclei on the spiral arms are sufficiently sharp and well defined to enable their relative positions on photographs taken at an interval of twenty or more years to be determined. In this way, angular motions have been detected which can be represented as the combination of a rotation of the nebula as a whole with an outward motion of the nuclei along the spiral arms. The rotational motion corresponds to a period of about the order of one or two hundred thousand years, though the uncertainty attaching to this figure is naturally great. In the case of spirals which are seen nearly edgewise on, a rotational motion can be detected by means of radial-velocity observations. Such observations have established for several nebulae a rotation about an axis perpendicular to the plane of the spiral arms. The rotation seems to occur as though the nebula were a rigid body.

The spectra of spiral nebulae are continuous with superposed absorption lines. They are therefore not gaseous objects. The spectral type corresponds to the spectral classes F5 to K. It is impossible to decide at present whether the absorption lines are merely the integrated spectra of stars associated with the nebula, the nebulosity being attributed to matter in a state of meteoric dust, or whether the nebula is in reality merely an aggregation of stars. Against the latter supposition is the fact that the most powerful telescopes have failed to resolve even the large nebula in Andromeda into discrete stars.

234. Distances of Spiral Nebulae.—Nothing definite can be stated with regard to the distance of spiral nebulae.

Their distances are certainly too great to be determined by trigonometrical methods, and as yet no indirect method has been found which will enable them to be determined with a sufficiently small percentage error to be considered at all reliable. It is possible, however, to obtain some qualitative ideas as to the distances of these objects.

The average velocity of the spirals across the line of sight must, in view of the values found for their radial motions, be at least several hundred km. per second. At various distances a velocity of 700 km. per second would produce annual proper motions as follows :—

Distance in light-years	1,000	10,000	100,000	1,000,000
Annual proper motion	0".48	0".048	0".005	0".0005

A value of 0".48 would have been detected long ago and may be excluded. A value of 0".048 would not probably have escaped detection with photographs extending over twenty-five years. It would appear from this argument that the distances are not less than about 10,000 light-years, but they may be much greater.

Comparing the linear velocities of rotation of spirals seen edgewise with the angular velocity of rotation for M 101, which is viewed broadside on, and making the assumption that the two rotations are comparable, the distance found for M 101 would be about 25,000 light-years.

Another argument can be derived from the appearances of new stars in spiral nebulae. Comparison of photographs of several of the larger spirals, taken at intervals of some years, has revealed the presence of stars with the characteristics of new stars. Several such stars have appeared, for instance, in the Andromeda nebula, one of which reached the seventh magnitude. On the grounds of probability, it must be assumed that these stars are physically connected with the nebula and not merely seen in projection upon it, particularly as novæ very rarely appear outside the galactic plane. If it is legitimate to assume that the new stars in the spirals have on the average the same absolute brightness at maximum as the galactic novæ, it is possible to deduce a hypothetical parallax for a spiral in which novæ have been detected. The distances of only four galactic novæ have been determined, and

these correspond to a mean absolute magnitude for the novæ in question of -3 m. at maximum and $+7$ m. at minimum. Now 16 novæ in the Andromeda nebula had a mean apparent magnitude at maximum of 17 m. If the distance of the nebulae is (i) 500,000 light-years, (ii) 20,000 light-years, the corresponding absolute magnitudes would be respectively -4 m. and $+3$ m. This slender material would seem to imply a distance of the order of 500,000 rather than one of 20,000 light-years, and the smaller spirals would presumably be at even greater distances; but it is doubtful whether much reliance can be placed upon the underlying assumptions. If the measured angular rotations of spirals can be accepted as of the right order of magnitude, distances of this order would correspond to impossibly large velocities. On the whole, the balance of evidence at present, although indicating that the distance of the spirals is large, say of the order of 25,000 light-years or more, seems to be opposed to the acceptance of such large distances as are deduced from the magnitudes of novæ.

235. The Nature of Spiral Nebulae.—Much controversy has raged as to the nature of spiral nebulae. The view held recently, when our galactic system was thought to be of much smaller dimensions than is indicated by more modern evidence, was that they were separate galactic systems. In support of this view was advanced the oblate shape of the systems when seen edgewise on and the appearance of the spiral arms, which were held to be analogous to the Milky Way. The spectra were taken as indicating that the spirals consisted of discrete stars. The large velocities—much greater than are found for any other celestial objects—seemed not unnatural on this hypothesis, and their distribution, which shows no relationship to the galaxy, was not opposed to it.

On the other hand, the distances found for globular clusters indicate that the dimensions of our galactic system are of the order of at least 300,000 light-years. The measures of rotation in spirals do not seem to permit, in some cases at least, of distances of this order, and this being so, the spirals must be members of our galactic system. Further, Seares has made a careful study of the surface brightness of the Milky Way, from which it must be concluded that none of the known spiral

nebulae has a surface brightness as small as that of our galaxy. Recent investigations of the distribution of light and colour in various spirals also seem to render it improbable that they can be stellar systems. If they are members of one great stellar universe, then the significance of their shape and large velocities remains obscure.

Although the balance of evidence at present seems opposed to the island-universe theory, the question cannot be regarded as yet definitely closed.

236. The Course of Stellar Evolution.—The Harvard system of classification of stellar spectra was based solely upon a study of the spectra without any consideration of a possible bearing upon the order of stellar evolution. The sequence finally adopted, types B, A, F, G, K, M, corresponds, as we have previously seen, to a gradual and progressive change in the nature of the spectra. The fact that the spectra of type B are allied to those of the Wolf-Rayet stars and to the gaseous nebulae suggested that the sequence corresponded also to the successive stages in the evolution of a star. The gradual progression in average velocity with type and other kindred phenomena appeared to give support to this theory. In course of time, however, other results were derived which did not fit in with so simple a theory and necessitated its modification.

In the early parallax investigations, stars with large proper motion were alone selected; these may be expected to be on the average the nearest stars, and therefore the stars whose distances can be most easily determined. We have also seen that it is possible to derive mean distances for groups of stars of known proper motion, by using the components of the proper motions towards the solar apex, assuming the solar velocity known and that the peculiar motions of the stars are distributed at random. The surprising result is obtained from these two lines of investigation that in the former case, with few exceptions, all the stars of late type (K and M) are of low intrinsic brightness, whereas in the latter case the mean intrinsic brightness is high. The increase in accuracy in parallax determinations has confirmed the wide range in luminosity in stars of late types, but it has shown further that stars of these types are either intrinsically bright or intrinsi-

cally faint, and that the separation into two classes previously indicated is a physical reality and not a spurious result due to the selection of material. This is the basis of the hypothesis of "giant" and "dwarf" stars put forward originally by Hertzsprung and developed and confirmed by Russell. (*See also* § 199.)

According to this theory, each spectral type consists of two subdivisions, consisting respectively of stars of high and low luminosity, which are called for convenience "giants" and "dwarfs" respectively. If the latter are more abundant than the former, the selection of the nearer stars will be mainly a selection of stars of low luminosity, whilst the stars in star catalogues, which are more distant and are selected by magnitude, will be mainly of high luminosity, and are the stars used for statistical investigations. The two classes are widely separated in the case of stars of type M, less widely separated for type K, for types F and G they begin to merge into one another, whilst for types B and A they cannot be distinguished. Thus, for instance, Adams and Joy find from spectroscopically determined parallaxes mean absolute magnitudes for the two classes as follows:—

Spectrum . . .	Ma-Md	K9-K4	K3-K0	G9-G0	F9 F0
Giants	1.6 m.	1.4 m.	1.3 m.	0.6 m.	1.1 m.
Dwarfs	10.8 m.	7.8 m.	6.3 m.	5.3 m.	4.1 m.

It will be seen that the absolute magnitudes of the "giants" is approximately the same for stars of all types, whereas the "dwarfs" increase in brightness with the sequence from M to B.

These results may be correlated with the determinations of the densities of visual and spectroscopic binary systems. For types B and A the densities are mainly included within the range 0.50 to 0.05, that of water being taken as unity, but for types F, G, and K there is an increasing range in density, values exceeding 1.0 and less than 0.0001 occurring, the median values at the same time being absent. This suggests that the separation into giants and dwarfs may be a separation according to density.

At this stage, the theoretical aspect of the question may be considered. According to theories advanced by Lane and Ritter, a star, assumed to be gaseous and in a highly diffused

state, will gradually contract under the influence of its own gravitational attraction, and this contraction will be accompanied by an increase in temperature due to the conversion of gravitational energy into heat. For a certain critical concentration, the loss of heat by radiation will be equal to the gain resulting from the contraction, and thereafter the temperature will decrease. We have seen that such a theory gives rise to difficulties with regard to the age of the Sun, but it is nevertheless probable that the course of evolution in a diffuse gaseous mass will be accompanied at first by a rise and subsequently by a fall in temperature. We have further seen that the spectrum of a star is conditioned mainly by ionization processes in its atmosphere and that these in turn depend mainly upon temperature. A classification of stars by spectra will therefore be mainly a classification according to temperature (as we have indeed seen in § 191), irrespective of physical state. Stars of the same type may therefore include diffuse masses of low density, or stars of relatively high density, and as we know that stars have all much the same mass, the stars of low density will have a much larger superficial area and a much higher luminosity than those of high density.

This is the basis of the theory advanced by Russell and now generally accepted. Starting with a diffuse mass of gas of low density (of the order of one ten-thousandth that of the Sun) and temperature, the mass gradually contracts, the temperature increasing and the luminosity remaining approximately constant. As the evolution proceeds the spectrum runs through the sequence M, K, G, F, A, B, the temperature increasing throughout. The stage is then reached at which the temperature commences to decrease, the density being of the order of one-tenth that of the Sun. The spectrum runs through the same sequence in the reverse order, the density increasing throughout. The maximum temperature attained will depend upon the mass of the star, so that a star of small mass may reach its maximum before arriving at the type-B stage. This seems to be confirmed by observation, for it is found that on the average the stars of type B are more massive than the bulk of the stars. Stars on the branch with increasing temperature are the "giant" stars; they are relatively large and of low density; those on the decreasing-

temperature branch are the "dwarf" stars, and are relatively small and of high density.

It must not be assumed that the spectra of a giant and dwarf star of the same spectral type are identical. Certain differences in relative intensities of a few lines have been found, which have been made the basis of the spectroscopic determinations of absolute magnitudes. The lines in question are some which are very sensitive to pressure changes. Moreover, there is a difference between the two classes as regards the general distribution of intensity throughout the spectrum, the giant stars being relatively the redder.

The following table gives particulars of typical giant and dwarf stars, the diameters in terms of the Sun being deduced theoretically:—

GIANTS.

Star.	Parallax.	Visual Mag.	Abs. Mag.	Spectrum.	Angular Diam.	Linear Diam. (Sun = 1).
	"	m.	M.		"	
μ Geminorum	·026	3·2	+ 0·3	Ma	·016	65
Aldebaran	·055	1·1	− 0·2	K5	·024	48
Arcturus	·095	0·2	+ 0·1	K0	·021	24
η Draconis	·019	2·9	− 0·7	G5	·004	21
α Leporis	·018	2·7	− 1·0	F0	·002	9
Regulus	·033	1·3	− 1·1	B8	·002	5
β Centauri	·037	0·9	− 1·3	B1	·001	4

DWARFS.

Star.	Parallax.	Visual Mag.	Abs. Mag.	Spectrum.	Angular Diam.	Linear Diam. (Sun = 1).
	"	m.	M.		"	
Sirius	·376	− 1·6	+ 1·3	A0	·007	2·0
Procyon	·304	+ 0·5	+ 2·9	F5	·006	2·0
λ Serpentis	·086	4·4	+ 4·1	G0	·001	1·5
11 Leo Minoris	·140	5·5	+ 6·2	K0	·002	1·5
61 Cygni	·303	5·6	+ 8·0	K5	·003	1·1
Lacaille 9,352	·290	7·4	+ 9·7	Ma	·002	0·9
Lalande 21,185	·414	7·6	+ 10·7	Mb	·002	0·6

The table shows the approximate constancy of the absolute magnitudes of the giant stars and the progressive change with spectral type of those of the dwarfs. The large diameters of the giant red stars should also be noted.

237. The Interior of a Star.—Some physical support is given to this theory—which was based by Russell upon purely observational evidence—by a mathematical discussion of the processes which take place in the interior of a star. The latter has been made by Eddington, using as a basis Schwarzschild's theory of radiative equilibrium. This theory supposes that the main factor responsible for the transfer of energy within a star is not conduction or convection but radiation. Consider a spherical layer within a star. Energy coming from the interior layers falls on this layer. Some of the energy is absorbed by the layer and the remainder is transmitted onwards. The layer, on the other hand, is itself sending out energy towards the outer layers. The energy received must balance that emitted in order that there may be a steady state. This provides one physical condition. Another is obtained by equating the difference of pressure on the two sides of the layer to the gravitational attraction towards the centre: but the pressure to be used is not the ordinary gas pressure; to this has to be added the pressure due to the radiation. The latter, normally negligible, becomes important in the interior of a star where the temperature is high (at the centre it may amount to one million degrees), and the essential feature of Eddington's theory is the recognition of this fact. To determine the three quantities pressure, temperature, and density at any point a third relationship is necessary: in the case of a giant star it may be assumed that the ordinary gas-laws hold, and this provides the third condition. The equations so obtained hold everywhere within the star except near the surface, to a depth negligible compared with the radius, but deep from the point of view of the spectroscopist. To complete the solution a few simplifying assumptions are made—that the absorption coefficient is constant throughout the star and that the molecular weight may be taken as 2, on account of the completeness of the ionization at the high temperatures concerned.

The theory then proves that under these assumptions the total radiation is independent of the stage of evolution, so that for giant stars the absolute magnitude remains constant whatever the spectral type. We have seen that this is actually the case, and the agreement with theory may be taken as confirmation of the underlying assumptions. It is also found that the effective temperature of the giant star will vary as the sixth root of its density. The theory seems in addition to point to the cause which determines the mass of a star. We know that the masses of the great majority of the stars fall within a comparatively narrow range from about the mass of the Sun to twenty times that amount. For the latter mass, the theory indicates that four-fifths of its gravitation is balanced by the pressure of radiation, and under the action of these two opposed and nearly balanced forces the star would probably be on the verge of instability. High radiation pressure, in fact, seems to produce a state in which a star may easily be broken up by rotation or other disturbing cause. The mass of the giant star determines its absolute magnitude: a giant star of mass one-half that of the Sun will have an absolute magnitude of -2.6 m., and one of 4.5 times the Sun's mass will have an absolute magnitude of -2.4 m.

If the density of the star is too great to enable the laws of a perfect gas to be applied, the theory becomes more uncertain because further assumptions must be made. Eddington assumed that van der Waal's equation holds in the interior, adjusting the constants to agree with observation at two points, and was able to calculate the effective temperatures of stars of various masses and densities. The results show that stars of small mass cannot rise to such high temperatures as more massive stars, which supports Russell's contention: in particular, a star of mass less than one-seventh of the Sun could not attain an effective temperature of $3,000^{\circ}$, and would therefore never become visible. In this connection it is suggestive that no star is known with a mass less than one-tenth that of the Sun. The absence of type-M stars of a range of absolute magnitude between the giants and the dwarfs indicates that stars of less than half the Sun's mass are comparatively uncommon. To reach the B-type stage, a mass at least 2.2 times the Sun's mass is necessary. Approximate determinations of

the effective temperatures of stars of different types are deduced from the theory, which agree well with observation. The theory in fact correlates many phenomena, supplies a physical basis for Russell's theory, and gives a sufficiently accurate picture of the phenomena taking place in the interior of a star.

238. Theories of Cosmogony.—We have gained some insight into the nature of the interior of a star and of the processes of evolutionary development of an individual star. But we have also seen that the Universe is not a mere collection of isolated stars: there are more complex structures which are met with so frequently that involuntarily we ask ourselves the question how they have come to exist. Spiral nebulae, globular clusters, double and multiple stars—so many examples of each type of system are known that in each case a common process of formation and development must have taken place. There is also our solar system itself: though unique in the stellar universe as far as we are aware, it is possible that there may be many similar systems which observation can never reveal to us. How have these various structures been formed? Many theories of cosmogony have been advanced to account for some of them. All are more or less speculative, though some are more plausible than others; none are entirely free from objections. It would be outside the scope of this volume to give more than a brief summary of a few of these theories with an indication of the present position of the problem. Although most of the theories of cosmogony were propounded originally with a view to explaining the structure of the solar system, the majority of them may more appropriately be utilized to explain some of the other structures.

239. The Theory of Laplace.—Laplace supposed the solar system to have originated out of a flattened mass of gas or nebula, extending beyond the present orbit of Neptune, which was at the outset at a high temperature and in rotation. The mass gradually cooled by radiation at its surface, and at the same time contracted under the influence of its own gravitation. This resulted in a heating of the central portion

and an increase in the angular velocity of rotation, since the angular momentum must necessarily have remained constant. With continual increase in the angular velocity, the centrifugal force at the equator at length became greater than gravity; Laplace supposed that as a result a ring of matter was left behind along the equator and that further contraction detached a series of such rings. Each ring was supposed to break up and condense into a gaseous planet which in turn went through a similar process of evolution on a smaller scale, resulting in the formation of satellites. The theory, it will be seen, is given a form which might explain the ring-system of Saturn, as well as the satellites of the other planets, but it does not attempt to explain why the supposed ring-systems should become unstable and break up, nor why the ring system of Saturn remained stable.

The objections to this theory, as applied to the solar system, are numerous and strong.

1. The angular momentum of the system must have remained constant during the evolution. It is found by mathematical investigation that this angular momentum would not have been sufficient to cause the detachment of matter when the system extended to any of the planets unless the original nebula was very strongly condensed towards the centre.

2. The matter left behind during the contraction would not form definite rings; the separation of matter would be continuous and lead to another gaseous nebula, not in rotation.

3. Even if the rings were produced as the theory requires, these rings could not condense into a planet.

4. The theory is not able to account for satellites revolving in the opposite direction to their primaries, as do two of the satellites of Jupiter and one of Saturn. Nor can it account for satellites revolving in a shorter time than their primaries, as in the case of Phobos, one of the satellites of Mars.

Laplace's theory presupposes that all the planets were formerly gaseous. Jeans has investigated whether by modification the theory might be made more plausible. He finds that before the ejected matter could form a ring it must have increased in density to the order of 200 times the density in the outer regions of the nebula. This is only possible by supposing

that the ejected matter liquefied shortly after ejection. But this supposition in itself raises further difficulties: in order that this liquid mass should itself break up and produce satellites, an enormous shrinkage would be necessary, and even granting that this might have occurred, mathematical investigation shows that the break-up would then be into masses of comparable size. Moreover, the central mass ought to have continued disintegrating until a double star was formed. It seems probable, therefore, that this theory must be abandoned as far as the origin of the solar system is concerned.

240. The Planetesimal Theory.—This theory has been developed by Chamberlin and Moulton as an alternative to the theory discussed in the previous section. It supposes an initial non-rotating gaseous mass which, under the influence of its own gravitation, would be spherical in shape. If a second body passes sufficiently near this mass, tidal forces are produced, causing tidal protuberances to be raised directly under and directly away from the second body. As the bodies approach one another more closely, their tides will rise in height until, according to the theory, two jets of matter will rush out from the two antipodal points where the tides are highest. As the tide-raising body passes on, it will be somewhat ahead of the diameter through the tidal protuberances and the resulting couple will set the primary body in rotation. The two jets of nebulous matter are therefore ejected from a slowly rotating body and the ejected matter will take the form of two spiral arms. It is supposed further that the ejection takes place by pulsations, corresponding to the nuclei observed in the arms of a spiral nebula. This portion of the theory appears to give a reasonable explanation of the typical spiral form which is of such common occurrence.

The second part of the theory deals with the evolution of the ejected matter. It is supposed that the larger nuclei steadily grow by picking up the smaller ones, which are termed planetesimals, and so form planets. This process would result in a diminution of the eccentricity of the original highly-eccentric orbits. It is difficult to decide whether this would have happened or not, but it would seem that collisions between planetesimals must have been much more numerous than

collisions between planets and planetesimals, and that as a result of such collisions, the planetesimals would have been turned to gas before the nuclei could have gained much by accretion.

This theory, regarded as a theory of the origin of spiral nebulae, is open to strong objection, for it requires the close approach of two large bodies. Spiral nebulae, as we have seen, occur with very great frequency in the stellar system, whilst the close approach of two bodies required by the theory must be of very rare occurrence. On the grounds of probability, it is impossible that spiral nebulae in general can have been so formed. If we regard the solar system as an abnormal system with few other parallels in the Universe, Jeans has shown that a tidal theory will give a plausible explanation of its origin: though not free from objections, it provides a more satisfactory explanation than any alternative theory.

241. Jeans's Theory.—Jeans supposes that the relative velocity of the two bodies at the time of encounter was small. Matter was ejected slowly at first, but at a rate which increased gradually until the distance of closest approach was attained; thereafter at a rate decreasing and finally diminishing to zero. The result would be an ejected filament of matter, with density small at the ends and greatest near the centre. Owing to radiation, its temperature would fall most rapidly at the ends and more slowly near the middle, so that in course of time liquefaction would commence near the ends and ultimately instability would set in and the mass break up into detached masses. Jeans shows that the smallest masses would form out of the densest matter, so that the theory accounts for the two largest planets, Jupiter and Saturn, being in the middle of the series and explains why the smaller planets must have been liquid or solid from birth (to which other considerations also point) whilst the larger planets were probably gaseous. The tidal forces exerted on the planets by the Sun—the central mass—resulted, in a similar way, in the creation of systems of satellites. On this theory, the direction of revolution of the majority of the satellites is accounted for at once, and it also explains why their orbital planes are, with few exceptions, inclined at small angles to the orbital

planes of the planets. The theory also accounts for the comparative crowding of the planets near to the Sun and for the corresponding phenomenon in the systems of Jupiter and Saturn. The planets at the two ends of the series, Mercury, Venus, Uranus, and Neptune, which condensed to a liquid state at a very early stage, would not be likely to be broken up by tidal friction, and we should therefore expect them not to have satellites. The satellites of Uranus, which have a high inclination, and that of Neptune, which has retrograde motion, may have been otherwise formed. The satellites of Mars and the Earth-Moon system present difficulties on this as on other theories.

Other theories, such as the Capture Theory of See, have been put forward to account for the origin of the solar system, but they do not appear as plausible or to have so solid a foundation as the above and will therefore not be discussed here.

242. The Origin of Spiral Nebulæ.—Jeans has developed a theory of the origin of spiral nebulæ based upon a mathematical investigation of the behaviour of rotating, gravitating masses. He considers the permanent astronomical bodies as beginning existence as a gaseous mass in a state of extreme rarity. Such a mass, if out of the influence of other bodies, would assume a spherical form if not in rotation, or a spheroidal form if slowly rotating. Under the influence of the gravitational attractions of other masses, such a mass would be set in motion, and the tidal couples produced when any two masses pass in the neighbourhood of one another would gradually produce slow rotations. These would increase as the mass shrinks, the angular momentum remaining constant. The heavier elements will tend to collect near the centre, the lighter elements forming a surrounding atmosphere: there will thus be a central condensation of mass. Under such circumstances, with increasing rotation the mass will in time assume a lenticular figure with a sharp edge from which matter tends to be thrown off. Such a figure corresponds with the shape of certain nebulæ, such as N.G.C. 3,115 or N.G.C. 5,866. This figure will not rotate as a rigid body owing to viscosity, although the angular velocity will increase outwards from the centre.

In the unstable state, when matter is about to be thrown off, the exact points at which the break-up will commence are conditioned by the slight external gravitational field due to other and distant bodies. The cross-section will become slightly elliptical and the ejection will occur at the two ends of the major axis of this ellipse. Should there be no external field, matter would be ejected as a ring which would be disintegrated by its own rotation. In the case under consideration, the ejection will be in the equatorial plane, and theory shows that it will continue almost indefinitely from the same two antipodal points. The long streams of gas emitted must become longitudinally unstable and will tend to break up into condensations or nuclei under their own gravitational attraction, and in this way the nuclei observed on the arms of spiral nebulae might be accounted for. Jeans is able, from an examination of the conditions under which the ejected matter will condense into nuclei, to conclude that these nuclear condensations will have a mass comparable with that of the Sun, so that the masses of the spirals must be supposed to be enormously greater than that of the Sun. These results, which have a firm theoretical basis, are fully in accord with observation.

243. The Evolution of Star Clusters.—It is thought by some that the final process of disintegration which is going on in spiral nebulae, and which we have seen is progressive, will be a globular star cluster. In this connection, it is significant that many star clusters are found to have galactic planes of symmetry. The conjecture is not free from objections and cannot be regarded as in any sense established. But whether true or not, the question is suggested as to the final result of the evolution of star clusters.

A star cluster may be compared with a mass of gas, the individual stars corresponding to molecules. In the mass of gas, the molecules are moving about in different directions, and continually colliding with one another, until rapidly a steady state is attained in which the molecular velocities are distributed at random and the mean square velocity is the same in any portion of the gas. Will such a steady state be attained in a star cluster in astronomical time ?

In the star cluster the relative velocities of the stars are comparatively small and the density of matter is also very small. With reasonable estimates of these quantities for our local stellar system, it is found that there would be, on the average, only one direct collision between stars in a period of about 4×10^{12} years. As regards "encounters," when two stars approach sufficiently close for their mutual gravitation to influence their motion, it is found that there would on the average be only one encounter in 10^{11} years which would cause a deviation in path of more than 1° . These intervals of time are so long that the effect of only those feeble encounters which produce deviations of less than 1° need be considered. The result of this investigation is to establish that the feeble encounters with neighbouring stars may be neglected, and the changes in stellar velocities may therefore be regarded as coming from the forces exerted by the Universe as a whole. The problem then becomes a problem of the kinetic theory of gases, simplified by the omission of collisions.

Jeans finds that under these circumstances the only possible configurations when a steady state has been attained are those in which the stars form a spherically symmetrical figure or a figure of revolution symmetrical about an axis, but that the former could not have originated out of any system in which the angular momentum was not zero. In the latter case, the velocities at any point will not be distributed uniformly for all directions in space, in other words, the phenomenon of star-streaming will occur, the direction of streaming being along the axis of the system.

An investigation of the time required for a steady state to be attained for our Universe indicates that the approach to a final steady state, though fairly rapid in the early stages, must later be excessively slow—after an interval of 10 million years, the courses of the stars in our Universe will be but little altered. It might be concluded, therefore, that though our system is approaching a steady state, it has not yet reached it. If the steady state had been attained, the kinetic energy of every star would be the same and there would be no star-streaming. These conditions are not obeyed. For the globular clusters, on the other hand, it is estimated a steady state will

have been more nearly obtained than in our own system, but that they are hardly likely yet to have finally reached the steady state.

244. The Origin of Binary Stars.—The problem of the origin of binary and multiple systems is one beset with many difficulties, so that it is not easy to draw any definite conclusions. Considering one of the nuclei of the original nebula, it follows that this nucleus, originally in rotation, will continue to contract, its rotation meanwhile becoming more rapid until at length ejection of matter commences. This matter will not be ejected at a sufficient rate to condense into nuclei; it may either be dissipated into space or form an atmosphere about the star. Planetary nebulae, nebulous stars, and ring nebulae, may possibly be accounted for in this way. The equatorial ejection of matter will continue until a further critical density is reached, when a pseudo-ellipsoidal form develops which, under certain circumstances, will change to a pear-shaped figure and finally will develop a neck in the middle and divide into two detached masses, rotating about one another in the atmosphere of ejected matter. This atmosphere will ultimately condense round the two stars, leaving a binary system.

If the stars are regarded as masses of ordinary gas, fission cannot take place until the ideal gas laws are substantially departed from, at a density of something like $\frac{1}{4}$. It follows on this theory that no binary star which was formed by fission could have a density of less than about $\frac{1}{4}$, and also that no giant binary star could have been formed by fission. These conclusions cannot be reconciled with observation unless it is supposed that not all binaries have been formed by fission.

The theory probably requires modification on account of the very high temperature prevailing in the interior of a star, which causes almost complete ionization with a consequent reduction in the molecular weight. This might reduce the limit of the critical density from $\frac{1}{4}$ to $\frac{1}{60}$.

Granting that fission has occurred, further shrinkage will result in an increase in the rate of rotation of each star. The rotations will become more rapid than the mutual period of revolution and tidal couples will be produced, the effect of

which will be to tend to equalize the periods of rotation and of revolution. As a consequence of such tidal action, the evolution of the binary system should be accompanied by increasing separation, increasing period, and increasing eccentricity.

Statistics of binary systems appear at first sight to accord admirably with these conclusions, as will be seen by reference to the table given in § 219. A closer theoretical examination, however, indicates that there are limits to the possible increase with evolution of separation and period. The latus rectum of the orbit cannot increase by more than 90 per cent., and the greatest possible increase in period is one of 13.6 times with, however, in a very large majority of binaries, an increase not exceeding 4.4 times. The linear dimensions and period are not therefore subject to great changes. In the course of evolution, spectral type and eccentricity will vary, but the period remains of the same order. The theory therefore does not explain why short-period spectroscopic binaries have small eccentricities and are generally of early spectral type, whilst long-period binaries have high eccentricity and are generally of late spectral type.

Such an explanation may possibly be found in the general cumulative effect of successive stellar encounters. Theory proves that these produce the same general effects as tidal friction—increases in eccentricity, linear dimensions, and period—but that the possible increases bear no relation to the original values. The dependence of eccentricities and periods upon spectral type may possibly find an explanation in the hypothesis that the binary systems of late type were formed at a much earlier date than those of the B and A types, and that therefore close encounters have not only had a longer time in which to act but also in the early stages they would have been far more numerous. But this is barely more than conjecture.

Whilst some binary stars have undoubtedly been formed by fission as just described, it is very probable that others are systems which have evolved from two adjacent nuclei in the original nebular arms and have remained permanently in mutual rotation under their gravitational attraction.

245. **Multiple Stars.**—The question of the evolution of multiple stars may be briefly discussed. We commence with a binary system; each component will continue to shrink and the velocity of rotation to increase correspondingly. The effect of tidal friction will be to diminish somewhat the angular momentum of each component and therefore to delay a further fission. Neglecting such effect, theoretical investigation shows that a further fission cannot occur until the total increase in density since the first fission is 342 times, whilst the linear dimensions of the sub-system will be about one-seventh of those of the original system and its period will be about one-eighteenth that of the original system. The effect of tidal friction will be to increase these inequalities of dimensions, density, and period when fission occurs. For either component of the sub-system to divide again, the density must be at least $(342)^2$ or 11,700 times that at the original fission, and the period of the new sub-system will be less than $1/342$ times that of the primary system. A typical multiple system is that of Polaris, which is composed of a spectroscopic triple system having periods of 4 days and 12 years in rotation about a fourth visible star with a period of the order of 20,000 years.

INDEX

- Abbot, 137
 Aberration, 64; constant of, 66;
 chromatic, 163; diurnal, 68;
 spherical, 163
 Absorption of light in space, 360
 Acceleration, secular, of Moon, 88
 Adams, 208, 262
 Acrolites, 278
 Age of Moon, 79
 Albedo, 230
 Algol, 345
 Almuqantar, 4
 Altazimuth telescope, 178
 Altitude, 4
 Annual equation, 85
 Annular eclipse, 150
 Anomalistic period, 84; year, 69
 Antarctic Circle, 41
 Aphelion, 39
 Apogee, 39, 81
 Apparent place of star, 202
 Arctic Circle, 41
 Argelander, 287
 Aries, First Point of, 7
 Aristotle, 266
 Asteroids, size and number of, 244;
 orbits of, 245; origin of, 245
 Azimuth, 4; determination of, 204
 Azimuth error of transit circle, 175
- Baily's Beads, 155
 Barnard, 239, 250, 363
 Bayer, 285
 Belopolsky, 235
 Bérhol, 216
 Bessel, 203, 261, 311
 Binaries, spectroscopic, 327; orbits
 of, 328
 Binary Stars, 323; origin of, 349,
 384
 Black body radiation, 137
 Bode's Law, 216, 243
 Bohnenberger eyepiece, 174
 Bond, 255, 257
- Boss, 319
 Bouguer, 19
 Bouvard, 261
 Boys, 21
 Bradley, 63, 311
 Bredichin, 275
 Brown, 88
- Calendar, Gregorian, 70; Julian, 70
 Calendar reform, 71
 Campbell, 241, 318, 328
 Canals on Mars, 239
 Cancer, Tropic of, 41
 Capricorn, Tropic of, 41
 Cassegrain telescope, 165
 Cassini, 238, 255, 257
 Cavendish experiment, 20
 Celestial Equator, 4; sphere, 1
 Cepheid variables, 340; luminosity-
 period of, 342; pulsation theory
 of, 342
 Ceres, 243, 244
 Chamberlin, 379
 Chandler, 26
 Charlois, 244
 Chromosphere, 133
 Chronograph, 172, 179
 Clairaut, 87
 Cluster, local, 359
 Clusters, globular, 356; distance of,
 357; system of, 358; open, 362;
 stellar, 355; evolution of, 382
 Collimation, 172
 Colour index, 289, 306
 Colour of sky, 28
 Colure, equinoctial, 7
 Comets, 265; appearance of, 272;
 density of, 273; families of, 269;
 groups of, 270; number of, 265;
 old views on, 266; orbits of, 267;
 origin of, 268; periodic, 269; size
 and mass of, 272; spectra, 274;
 tail of, 274

- Conjunction, 76, 209 ; inferior, 209 ;
 superior, 209
 Constellations, stellar, 284
 Copernicus, 212, 284
 Corona, solar, 134
 Coronium, 135
 Cosmogony, theories of, 377
 Craters, lunar, 102
 Culmination, 7
 Curtis, 363

 Darwin, 106
 Date line, 55
 Dawes, 255
 Day numbers, 203
 Day, sidereal, 47 ; solar, 49
 Declination, 4 ; determination of, 201
 Deferent, 212
 Deimos, 242
 Denning, 248, 266, 332
 De Witt, 113
 Diameters, angular, of Stars, 315 ;
 of Planets, 220
 Differential observations, 201
 Diffraction grating, 295
 Dip of horizon, 32
 Distance of globular clusters, 357 ;
 Milky Way, 354 ; Moon, 94 ;
 spiral nebulae, 368 ; Stars, 310 ;
 Sun, 108
 Doppler's principle, 120
 Double Stars 323 ; masses of, 326 ;
 measurement of, 324 ; orbits of,
 325 ; origin of, 349, 384
 Draconian period, 84
 Draper catalogue, 304
 Dwarf Stars, 321, 372

 Earth, age of, 139 ; atmosphere of,
 28 ; eccentricity of orbit of, 39 ;
 ellipticity of, 16 ; interior of, 24 ;
 mass of, 17 ; mean density of, 24 ;
 orbit of, 37 ; rotation of, 11,
 14, 15 ; shape of, 11 ; size of, 15
 Earth's way, 66
 Easter Day, date of, 73
 Eccentricity of orbits, 39
 Eclipse limits, 142
 Eclipses, cause of, 141 ; lunar, 148 ;
 number in one year, 145 ; recur-
 rence of, 147 ; solar, 150 ; of
 Jupiter's satellites, 197
 Eclipsing variables, 344
 Ecliptic, 36 ; obliquity of, 36
 Eddington, 375
 Effective temperature of Stars, 307 ;
 Sun, 137
 Elements of planet's orbit, 216
 Elements in Sun, 119
 Ellipticity, 16
 Elongation, 210
 Encke, 255
 Enhanced lines, 133
 Epicyle, planetary, 212
 Epoch, 216
 Equation, annual, 85 ; of centre, 81 ;
 personal, 192 ; of time, 50
 Equator, Celestial, 4
 Equatorial telescope, 182
 Equinoctial colure, 7
 Equinox, 7, 36 ; autumnal and
 vernal, 7, 36 ; precession of, 58
 Eros, 113
 Error of clock, 182
 Evection, 83
 Evershed, 131
 Eyepieces, 169 ; Bohnenberger, 174 ;
 Huyghenian, 169 ; Ramsden, 169

 Fabricius, 337
 Faculae, 122
 Families of comets, 269
 Filar micrometer, 185
 Fizeau, 315
 Flash spectrum, 133
 Flamsteed, 286
 Flocculi, 130
 Foucault's experiment, 13
 Fowle, 137
 Fraunhofer spectrum, 133
 Fundamental observations, 201

 Galactic condensation of Stars, 352,
 353
 Galactic plane, 351
 Galaxy, 351
 Galileo, 102, 249, 254
 Gauss, 219, 243
 Giant Stars, 321, 372
 Gill, 112
 Globular clusters, 356 ; distance of,
 357 ; system of, 358
 Gnomon, 59, 195
 Golden number, 73

- Goodricke, 345, 347
 Graham, 181
 Gravitation, constant of, 17; determination of, constant of, 22; law of 17; universality of, 208
 Gregorian calendar, 70; telescope, 165
 Groups of comets, 270
 Grubb, 184
 Guillaume, 181

 Hale, 123, 130, 168
 Halley, 267, 284
 Hansen, 88
 Harvest Moon, 98
 Heliacal risings, 59
 Heliometer, 188
 Helium, 121
 Helmholtz, 138
 Henderson, 311
 Herschel, J., 287
 Herschel, W., 243, 257, 259, 260, 300, 323, 352, 362
 Hertzprung, 372
 Hipparchus, 60, 287
 Horizon, 3
 Horrocks, 110
 Hour angle, 5; circle, 4
 Huggins, 274, 299
 Huyghens, 180, 238, 255, 257
 Huyghenian eyepiece, 169

 Image, brightness of, 161
 Inferior conjunction, 209
 Interior of a Star, 375
 Invariable plane, 218
 Ionisation in stellar atmospheres, 308
 Irregular nebulae, 363
 Irregular variables, 339

 Janson, 333
 Jeans, 380, 383
 Jones, 319
 Julian calendar, 70; date, 72
 Juno, 244
 Jupiter, eclipses of satellites of, 197; orbit and size of, 246; physical state of, 248; red spot on, 248; rotation period of, 247; satellites of, 249; telescopic appearance of, 247

 Kapteyn, 301

 Keeler, 256
 Kepler, 266, 333
 Kepler's Laws, 39, 205
 Küstner, 26

 Lagrange, 218
 Lane, 372
 Langley, 137
 Laplace, 218, 259, 377
 Latitude, celestial, 37; determination of, 193; variation of, 26
 Law of equal areas, 206
 Law of gravitation, 17; universality of, 208
 Leonid meteor swarm, 281
 Level error of transit instrument, 172
 Leverrier, 208, 262, 263
 Libra, First Point of, 36
 Libration of Moon in latitude, 93; in longitude, 92
 Light ratio, 287
 Light, total, of Stars, 296
 Light-year, 310
 Local cluster, 359
 Local time, 54
 Lockyer, 121
 Longitude, celestial, 37; determination of, 195
 Long period variables, 336
 Lowell, 235, 240
 Luminosities of Stars, 321

 Magnetic, field of Sun-spots, 123; storms, 126
 Magnitudes of Stars absolute, 313; determination of absolute, 314; photographic, 288; visual, 286; determination of apparent, 289
 Maintenance of Sun's heat, 137
 Mars, 236; atmosphere of, 240; canals on, 239; orbit of, 236; polar caps of, 238; rotation period of, 237; satellites of, 242; size and shape of, 236; telescopic appearance of, 237; temperature of, 240
 Maskelyne, 19
 Mass of double stars, 326; planets 222
 Maunder, 126
 Maxwell, 255
 Mayer, 138
 Mean place of Star, 203
 Mean Sun, 52

- Mercury, 228; atmosphere of, 230; markings on, 230; physical nature of, 230; rotation period of, 229; size of, 229; telescopic appearance of, 229; transits of, 157
- Meridian, 3
- Meridian Circle, 177
- Meridian photometer, 291
- Meteors, 276; connection with comets, 280
- Meteor radiants, 278
- Meton, 72
- Metonic cycle, 72
- Michell, 323
- Michelson, 221, 315
- Micrometer, filar, 185
- Milky Way, 351; distance of, 354
- Minor planets (*see* Asteroids)
- Month, lunar, 76
- Moon, age of, 79; apparent motion of, 75; concavity of path to Sun, 89; distance of, 94; harvest, 98; librations of, 92; mass of, 96; orbit of, 81; origin of, 106; parallax of, 95; phases of, 77; physical conditions, 104; rising and setting on, 97; rotation of, 91; secular acceleration on, 88; sidereal revolution on, 76; size of, 95; surface structure on, 101; synodic revolution on, 76; tables of motion of, 87; tropical revolution on, 76
- Motion of planets, laws of, 205
- Motion in resisting medium, 224
- Moulton, 379
- Multiple Stars, 330; origin of, 386
- Nadir, 2
- Neap tides, 101
- Nebulæ, 362; distance of, 368; irregular, 363; nature of, 370; origin of, 381; planetary, 365; spiral, 367
- Nebulium, 364
- Neptune, 261; satellites of, 263; telescopic appearance of, 262
- Newton, 87, 206, 266
- Newtonian telescope, 165
- Nichols and Hull, 275
- Nodes of Moon's orbit, 81
- North polar distance, 4
- Novæ, 331; in spiral nebulæ, 369; spectral changes of, 334; theories of, 335
- Numbers of Stars of various magnitudes, 296
- Nutation, 63
- Obliquity of ecliptic, 36
- Occultations, 156
- Opposition, 76
- Orbit, of binary star, 325; determination of planet's, 219; elements of planet's, 216; of Moon, 81; spectroscopic binary, 328
- Origin of binary stars, 349; comets, 268; Moon, 106
- Palisa, 244
- Pallas, 243
- Parabolic velocity, 226
- Parallax of Moon, 95; Stars, 310; Sun, 108
- Parsec, 310
- Perigee, 39, 81
- Perihelion, 39
- Periodic comets, 269
- Periodicity of Sun-spots, 124
- Perrotin, 239
- Personal equation, 192
- Phases of Moon, 77; Venus, 232
- Phobos, 242
- Photographic magnitudes, 288; determination of, 294
- Photometer, meridian, 291; Zöllner, 289
- Piazzi, 213
- Pickering, 291, 328, 331, 338
- Planetary nebulæ, 365
- Planetesimal theory, 379
- Planets, 205; apparent motion of, 209; densities of, 223; diameters of, 220; determination of diameters of, 220; elements of orbits of, 216; determination of elements of, 219; laws of motion of, 205; mass of, 222; minor, 243; periods of, 221; statistics of, 227; surface gravities of, 223
- Pogson, 288
- Pole of celestial sphere, 2
- Poynting, 23, 241
- Precession, 58; physical cause of, 60; variation of, 62
- Pressure of radiation, 275
- Prime vertical, 3
- Prominences, solar, 130
- Proper motions, 297

- Ptolemaic system, 212, 233
 Ptolemy, 287
 Pulsation theory of cepheids, 342
 Purkinje effect, 293
 Pyrheliometer, 136

 Quadrature, 76, 209

 Radiation, pressure of, 275
 Radial velocity, 298
 Ramsden eyepiece, 169
 Rate of clock, 182
 Red spot on Jupiter, 248
 Reflecting telescope, 165
 Refracting telescope, 160
 Refracting and reflecting telescopes,
 relative advantages of, 167
 Refraction, atmospheric, 29; ele-
 mentary theory of, 30; law of, 30
 Resisting medium, motion in, 224
 Resolving power, 161
 Retrograde motion of planets, 210
 Reversing layer, 134
 Riefler, 181
 Right Ascension, 7; determination
 of, 201
 Ring system of Saturn, 253; dimen-
 sions of, 255; structure of, 255
 Ritter, 372
 Roemer, 251
 Russell, 321, 372, 373

 Saha, 309
 St. John, 123, 235
 Saros, 143
 Satellites of Jupiter, 249; Mars,
 242; Neptune, 263; Saturn, 257;
 Uranus, 260
 Saturn, dimensions of rings, 255; ring
 system of, 253; rotation period of,
 254; satellites of, 257; size and
 orbit of, 253; structure of rings of,
 255; telescopic appearance of, 254
 Schiaparelli, 239
 Schwabe, 125
 Schwarzschild, 303
 Seasons, 42; length of, 43
 Secchi, 304
 Seeliger, 257
 Shadow bands, 155
 Shapley, 354, 357
 Short period variables, 339
 Sidereal period, 214; time, 8, 47;
 year, 69

 Slipher, 235, 239
 Solar constant, 135; motion, 299
 Solstices, 36
 Spectra, 118; of comets, 274
 Spectral changes of novæ, 334
 Spectral types of stars, 304, 306;
 phenomena associated with, 319
 Spectroheliograph, 129
 Spectroscope, 118, 186
 Spectroscopic binaries, 327; orbits
 of, 328
 Sphere, celestial, 1
 Spiral nebulae, 367; distance of, 368;
 nature of, 370; origin of, 381
 Spring tides, 101
 Stability of solar system, 217
 Standard time, 54
 Stars, absolute magnitudes of, 313;
 angular diameters of, 315; distan-
 ces of, 310; effective tempera-
 tures of, 307; evolution of, 371;
 galactic condensation of, 352;
 giant and dwarf, 321, 372;
 interior of, 375; line of sight
 velocities of, 298; luminosities of,
 321; number of, 296; proper
 motions of, 297; spectral types of,
 304, 306; total light of, 296;
 variable, 331; velocities of, 321
 Star clusters, 355; evolution of,
 382
 Star streams, 301
 Statistics of planets, 227
 Stellar magnitudes, 286
 Stefan's law, 137
 Strömgren, 267
 Struve, 311
 Sumner line, 199
 Sun, apparent motion of, 34; con-
 stitution of, 118; corona of, 134;
 declination of, 40; distance of, 108;
 mass of, 115; parallax of, 108;
 prominences on, 130; rotation of,
 117; size of, 115; spots on, 122;
 surface of, 121; temperature of,
 135; velocity of, 299
 Sunrise and sunset, times of, 53
 Sun spots, 122; magnetic field of,
 123; periodicity of, 124; spec-
 trum of, 122; vortices, 123
 Superior conjunction, 209
 Surface gravities of planets, 223
 Synodic period, 111, 214

- Talcott, 193
 Telescopes, 159; equatorial, 182; reflecting, 165; refracting, 160; resolving power of, 161; zenith, 189
 Temperature of Mars, 240; Stars, 307; Sun, 135
 Terminator, 79
 Thollon, 239
 Tides, 99
 Time, 46; apparent solar, 48; determination of, 191; determination of, at sea, 192; equation of, 50; local, 54; mean solar, 49; sidereal, 8, 47; standard, 54
 Titan, 257
 Torsion balance, 19
 Transit instrument, 171; adjustments of, 172; circle, 177
 Transits of Mercury, 157; Venus, 109, 157
 Triple Stars, 330
 Tropics, 36
 Tropical year, 68
 Twilight, 29; duration of, 42
 Tycho Brahe, 266, 334
 Uranus, 258; rotation period of, 260; satellites of, 260; telescopic appearance of, 260
 Variability of Earth's rotation, 15
 Variable Stars, 331; eclipsing, 344; irregular, 339; long period, 336; short period, 339
 Variation of latitude, 26
 Variation, lunar, 86
 Velocity, from infinity, 225; line of sight, 298; parabolic, 225; in planetary orbit, 225
 Venus, 231; appearance of, 228, 233; brightness and phases of, 232; physical conditions of, 235; rotation period of, 233; size of, 232; transits of, 157
 Vernal equinox, 7, 36
 Vertical, circles, 3; prime, 3
 Vesta, 244
 Visual magnitudes, 286; determination of, 289
 Vulcan, 263
 Vortices, Sun-spot, 123
 Wolf, 244
 Wolf-Rayet Stars, 305, 354, 363, 366
 Year, anomalistic, 69; civil, 69; sidereal, 68; tropical, 68
 Zeeman effect, 123
 Zenith, 2; distance, 4; telescope, 189
 Zodiac, 36
 Zodiacal light, 281; spectrum of, 282
 Zöllner photometer, 289
 Zone time, 55

